

LOC	DIST	REV	DATE	APPV
A1	-	A	22MAR2013	RD CE

DELIVERY CONDITION AS SHOWN
 Lieferzustand wie gezeigt

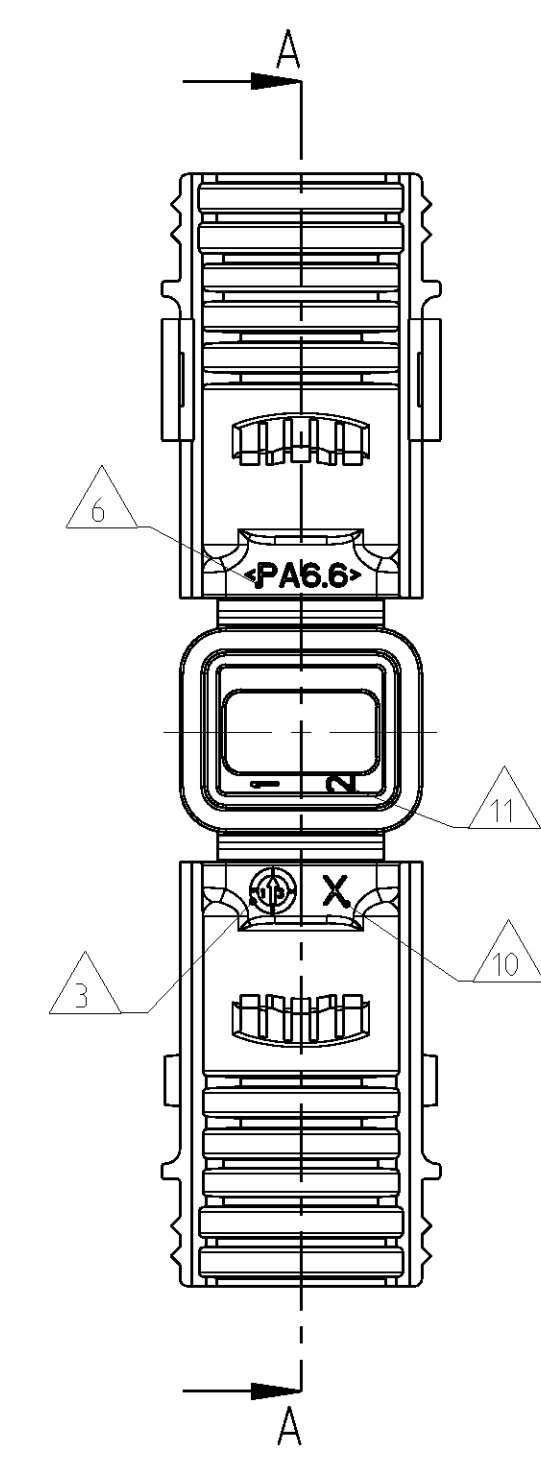
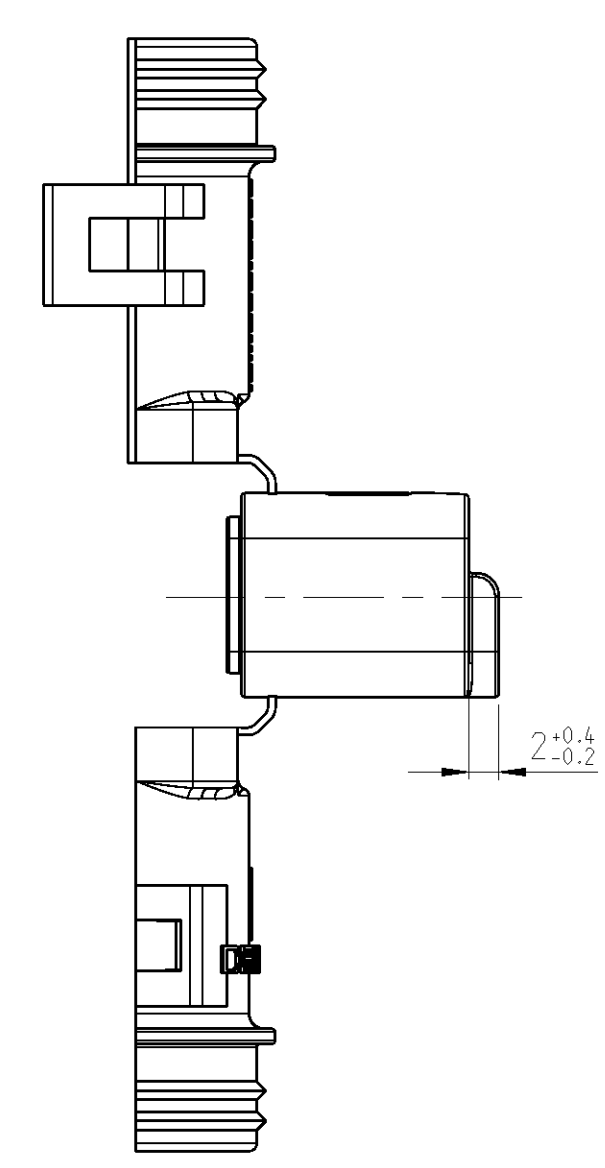
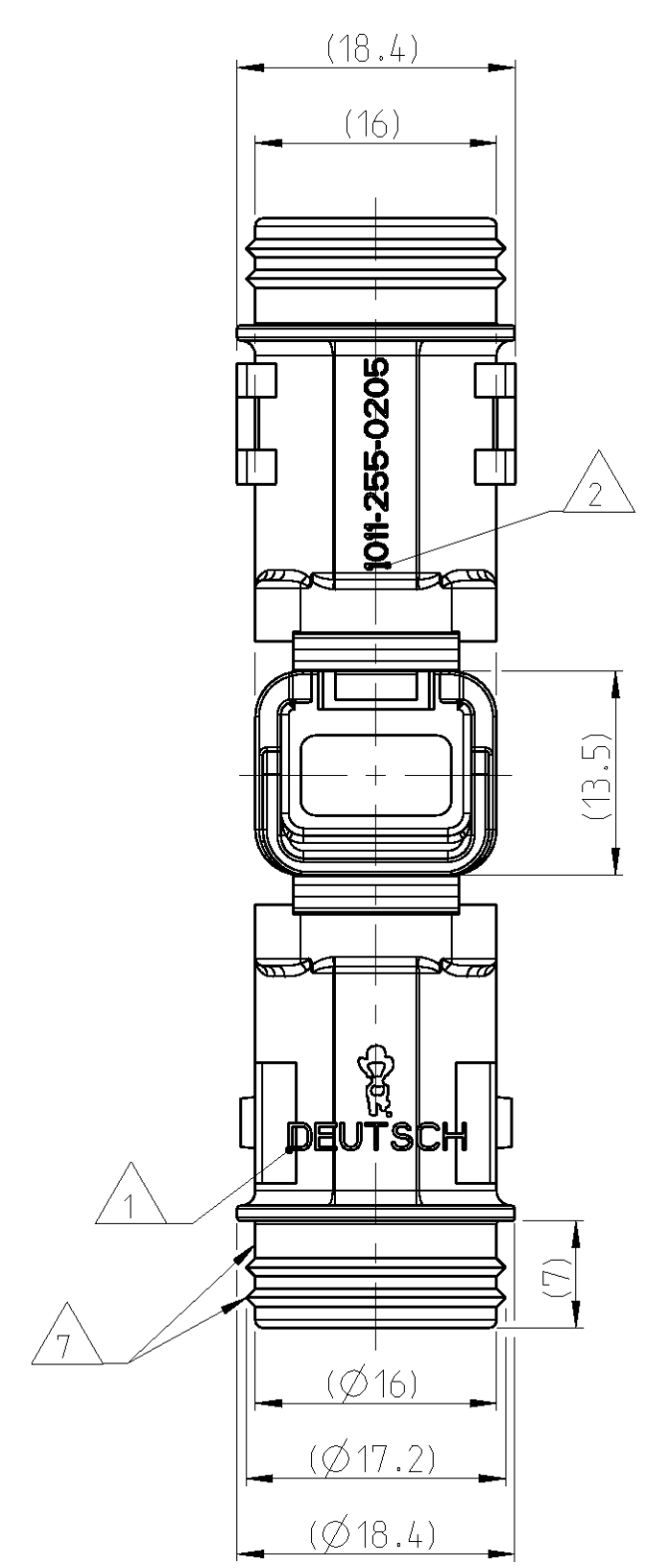

NOTES
 Bemerkungen

- 1 DEUTSCH LOGO
DEUTSCH Logo
- 2 DEUTSCH PART-NO
DEUTSCH Teil-Nr.
- 3 PRODUCTION DATE
Produktionsdatum
- 4 BULK PACKAGING IN PLASTIC BAG
Schueltgut im Plastikbeutel
- 5 MALFUNCTION CAUSED BY LAQUER IS
NOT COVER BY TE WARRANTY
Funktionsbeeinträchtigung durch Lackieren liegt
nicht im Einfluss und Gewährleistungsumfang von TE
- 6 MATERIAL MARKING ACCORDING TO VDA 260
Werkstoffkennzeichnung nach VDA 260
- 7 FOR HEAT-SHRINK TUBING AND TUBE WITH TIE WRAP
Fuer Schrumpfschlauch und Schlauch mit Kabelschelle
- 8 STRAIN RELIEF FOR SHEATED CABLES
Zugentlastung fuer Mantelkabel
FROM / von Ø5.2 UP TO / bis Ø7.6
- 9 FOR CORRUGATED TUBES: NW 6/7.5/8.5/10
Fuer Wellrohre: NW 6/7.5/8.5/10
- 10 MOULD CAVITY MARKING (IF NECESSARY)
Nestmarkierung (falls notwendig)
- 11 CAVITY MARKING
Kammerbezeichnung
- 12 MATED WITH ALL MODIFICATION OF DT06-02S
(WITHOUT ANY WELDED / MOUNTED PARTS)
Passend zu allen Varianten von DT06-02S
(ohne verschweißte / montierte Teile)
- 13 BASED ON THE HINGE MECHANISM OF THE CAP,
THE DELIVERY CONDITION CAN BE DIFFERENT
TO THE SHOWN STATUS.
Basierend auf dem Klappmechanismus der Kappe, kann der
Lieferzustand von der dargestellten Ansicht abweichen.

SECTION A-A
 Schnitt
 SCALE 5:1
 Maßstab

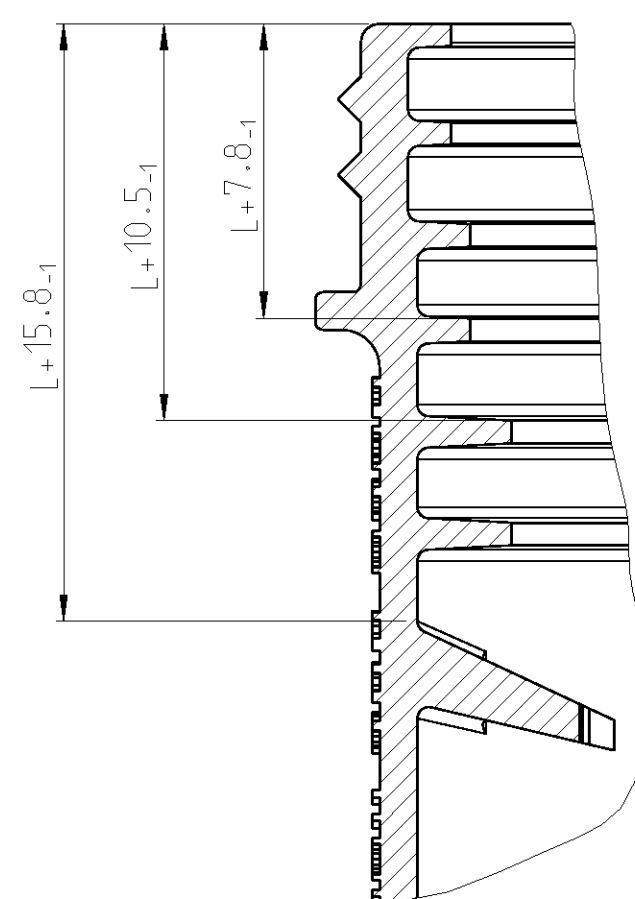

L+ = ADD LENGTH FOR CORRUGATED TUBE
 zus. Länge des Wellrohres

CLOSED (MOUNTED) CONDITION AS SHOWN
 Geschlossener (montierter) Zustand wie gezeigt

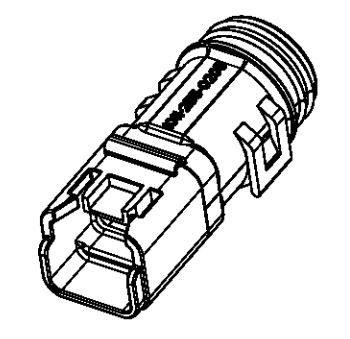
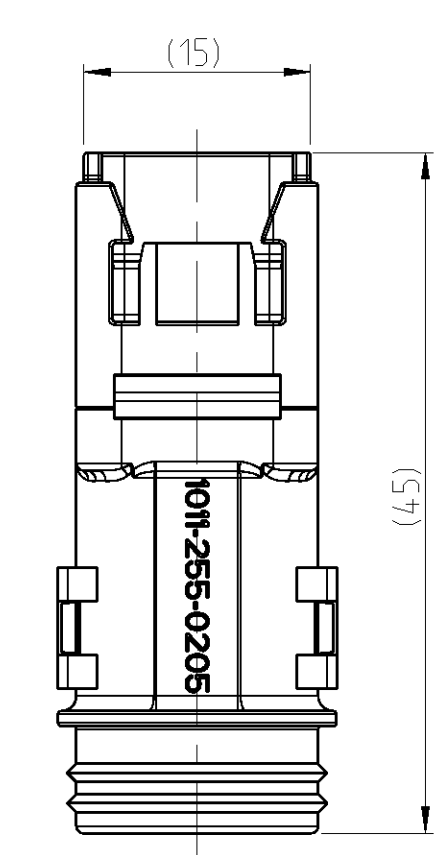
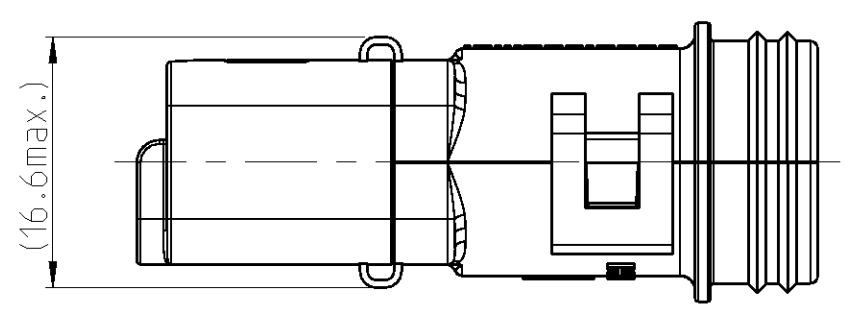
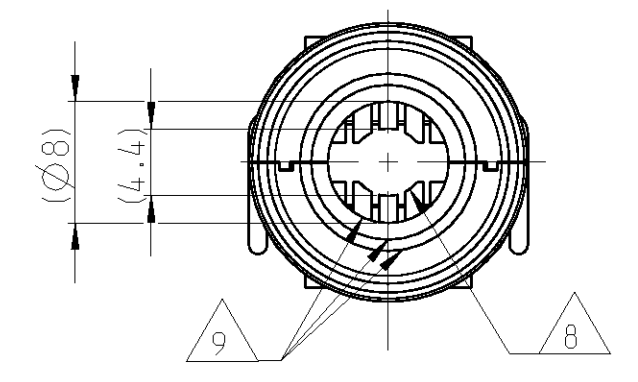

SCALE 1:1
 Maßstab

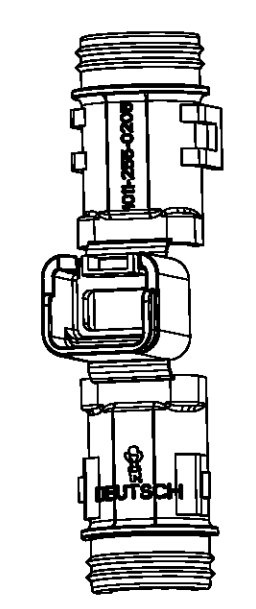

SCALE 1:1
 Maßstab

TOLERANCES UNLESS OTHERWISE SPECIFIED ACC. TO DIN 16901-140 CENTRIC TO NOMINAL DIMENSION, EDITION 1992-11. FREIPOSTTOLERANZEN NACH DIN 16901-140. ES GILT DIE AUSGABE 1992-11.																											
DIESE ZEICHNUNG IST EIN KONTROLLIERTES DOKUMENT. BEMASSUNGEN UND TOLERANZEN GEMAESS GPS (ISO STANDARDS).																											
THIS DRAWING IS A CONTROLLED DOCUMENT. DIMENSIONING AND TOLERANCING PER GPS (ISO STANDARDS)																											
DIMENSIONS: MASSENMESSEN mm	TOLERANCES UNLESS OTHERWISE SPECIFIED: ALLE DIMENSIONEN ACC TO ISO 2015																										
<table border="1"> <tr><td>1</td><td>±0.1</td></tr> <tr><td>2</td><td>±0.1</td></tr> <tr><td>3</td><td>±0.1</td></tr> <tr><td>4</td><td>±0.1</td></tr> <tr><td>5</td><td>±0.1</td></tr> <tr><td>6</td><td>±0.1</td></tr> <tr><td>7</td><td>±0.1</td></tr> <tr><td>8</td><td>±0.1</td></tr> <tr><td>9</td><td>±0.1</td></tr> <tr><td>10</td><td>±0.1</td></tr> <tr><td>11</td><td>±0.1</td></tr> <tr><td>12</td><td>±0.1</td></tr> <tr><td>13</td><td>±0.1</td></tr> </table>	1	±0.1	2	±0.1	3	±0.1	4	±0.1	5	±0.1	6	±0.1	7	±0.1	8	±0.1	9	±0.1	10	±0.1	11	±0.1	12	±0.1	13	±0.1	FINISHES UNLESS OTHERWISE SPECIFIED: ALLE OBERFLÄCHEN SIEHE TABELLE
1	±0.1																										
2	±0.1																										
3	±0.1																										
4	±0.1																										
5	±0.1																										
6	±0.1																										
7	±0.1																										
8	±0.1																										
9	±0.1																										
10	±0.1																										
11	±0.1																										
12	±0.1																										
13	±0.1																										
<table border="1"> <tr> <th>ORDER-NO. Bestell-Nr.</th> <th>REV.</th> <th>WEIGHT (g)</th> <th>MATERIAL</th> <th>COLOUR Farbe</th> <th>DESCRIPTION Beschreibung</th> <th>ITEM</th> </tr> <tr> <td>1011-255-0205</td> <td>K</td> <td>4.44</td> <td>NYLON 6/6</td> <td>BLACK schwarz</td> <td>COVER WITH STRAIN RELIEF Kappe mit Zugentlastung</td> <td>1</td> </tr> </table>		ORDER-NO. Bestell-Nr.	REV.	WEIGHT (g)	MATERIAL	COLOUR Farbe	DESCRIPTION Beschreibung	ITEM	1011-255-0205	K	4.44	NYLON 6/6	BLACK schwarz	COVER WITH STRAIN RELIEF Kappe mit Zugentlastung	1												
ORDER-NO. Bestell-Nr.	REV.	WEIGHT (g)	MATERIAL	COLOUR Farbe	DESCRIPTION Beschreibung	ITEM																					
1011-255-0205	K	4.44	NYLON 6/6	BLACK schwarz	COVER WITH STRAIN RELIEF Kappe mit Zugentlastung	1																					

TOLERANCES UNLESS OTHERWISE SPECIFIED ACC. TO DIN 16901-140 CENTRIC TO NOMINAL DIMENSION, EDITION 1992-11. FREIPOSTTOLERANZEN NACH DIN 16901-140. ES GILT DIE AUSGABE 1992-11. DIESE ZEICHNUNG IST EIN KONTROLLIERTES DOKUMENT. BEMASSUNGEN UND TOLERANZEN GEMAESS GPS (ISO STANDARDS). THIS DRAWING IS A CONTROLLED DOCUMENT. DIMENSIONING AND TOLERANCING PER GPS (ISO STANDARDS)																											
DIMENSIONS: MASSENMESSEN mm	TOLERANCES UNLESS OTHERWISE SPECIFIED: ALLE DIMENSIONEN ACC TO ISO 2015																										
<table border="1"> <tr><td>1</td><td>±0.1</td></tr> <tr><td>2</td><td>±0.1</td></tr> <tr><td>3</td><td>±0.1</td></tr> <tr><td>4</td><td>±0.1</td></tr> <tr><td>5</td><td>±0.1</td></tr> <tr><td>6</td><td>±0.1</td></tr> <tr><td>7</td><td>±0.1</td></tr> <tr><td>8</td><td>±0.1</td></tr> <tr><td>9</td><td>±0.1</td></tr> <tr><td>10</td><td>±0.1</td></tr> <tr><td>11</td><td>±0.1</td></tr> <tr><td>12</td><td>±0.1</td></tr> <tr><td>13</td><td>±0.1</td></tr> </table>	1	±0.1	2	±0.1	3	±0.1	4	±0.1	5	±0.1	6	±0.1	7	±0.1	8	±0.1	9	±0.1	10	±0.1	11	±0.1	12	±0.1	13	±0.1	FINISHES UNLESS OTHERWISE SPECIFIED: ALLE OBERFLÄCHEN SIEHE TABELLE
1	±0.1																										
2	±0.1																										
3	±0.1																										
4	±0.1																										
5	±0.1																										
6	±0.1																										
7	±0.1																										
8	±0.1																										
9	±0.1																										
10	±0.1																										
11	±0.1																										
12	±0.1																										
13	±0.1																										
<table border="1"> <tr> <th>ORDER-NO. Bestell-Nr.</th> <th>REV.</th> <th>WEIGHT (g)</th> <th>MATERIAL</th> <th>COLOUR Farbe</th> <th>DESCRIPTION Beschreibung</th> <th>ITEM</th> </tr> <tr> <td>1011-255-0205</td> <td>K</td> <td>4.44</td> <td>NYLON 6/6</td> <td>BLACK schwarz</td> <td>COVER WITH STRAIN RELIEF Kappe mit Zugentlastung</td> <td>1</td> </tr> </table>		ORDER-NO. Bestell-Nr.	REV.	WEIGHT (g)	MATERIAL	COLOUR Farbe	DESCRIPTION Beschreibung	ITEM	1011-255-0205	K	4.44	NYLON 6/6	BLACK schwarz	COVER WITH STRAIN RELIEF Kappe mit Zugentlastung	1												
ORDER-NO. Bestell-Nr.	REV.	WEIGHT (g)	MATERIAL	COLOUR Farbe	DESCRIPTION Beschreibung	ITEM																					
1011-255-0205	K	4.44	NYLON 6/6	BLACK schwarz	COVER WITH STRAIN RELIEF Kappe mit Zugentlastung	1																					



COVER, DT06-02S-BS180
 Kappe, DT06-02S-BS180
 BACKSHELL STRAIGHT (180 DEGREE)

SIZE	CAGE CODE	DRAWING NO.	RESTRICTED TO
A1	00779	1011-255-0205	NUR FÜR
Customer Drawing	/KUNDENZEICHNUNG	SCALE MAßSTAB 2/1	SHEET BLATT 1 OF VON 1