

### Specifications 规格

#### Electrical 电气规格

Voltage Rating 电压额定值: 20 V DC

Current Rating 电流额定值: 8 Amp

Insulation Resistance 绝缘电阻值: 100 MΩ min.

Dielectric Withstanding 耐电压: 500 V AC

Contact Resistance 接触电阻值: 30 mΩ max.

#### Mechanical & Environmental 机械 & 环境

Operating Temperature 工作温度: -20°C to +70°C

Durability 耐久性: 5,000 cycles min.

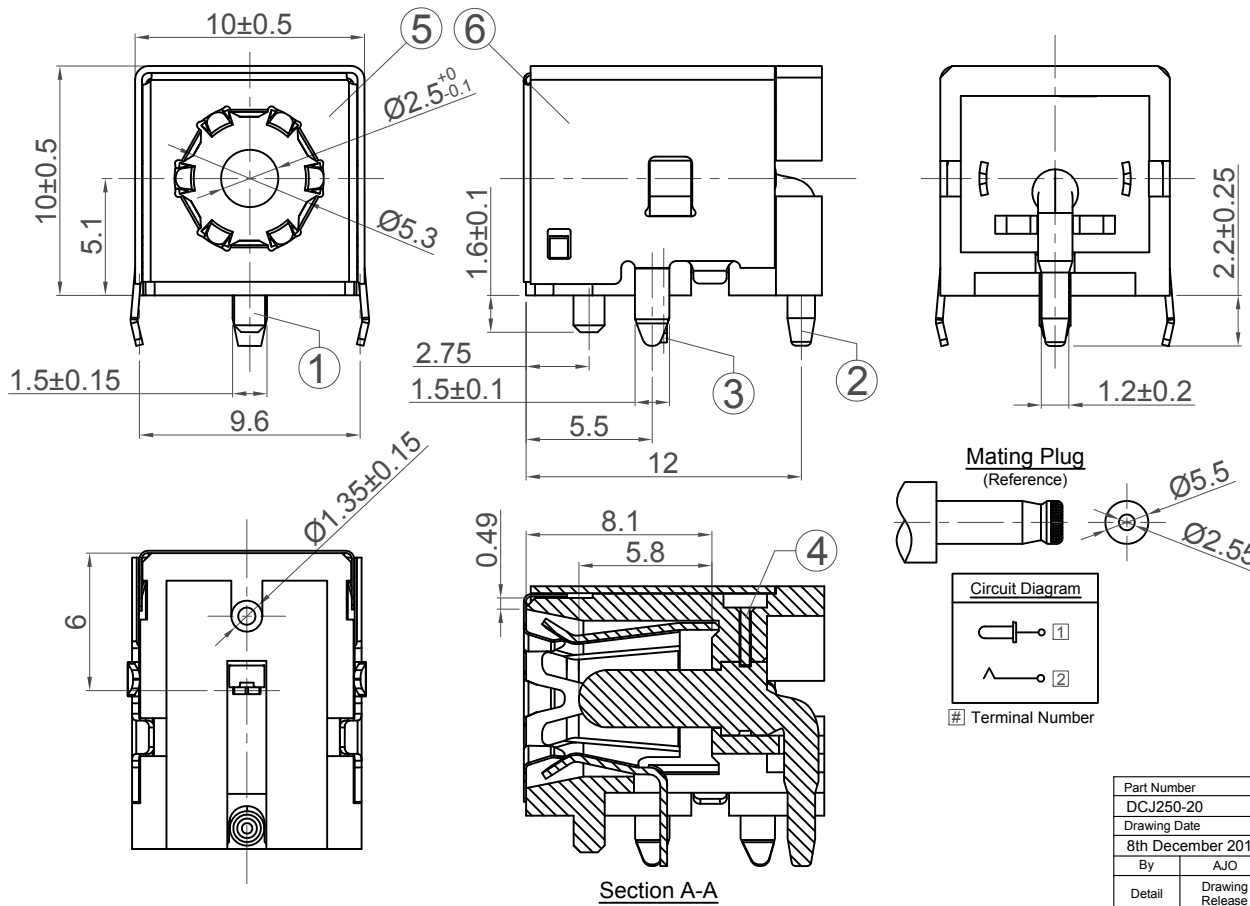

No.	Description	Material	Q'ty
①	Housing	PA10T, UL94 V-0	1
②	Centre Pin	① Zinc Alloy, Nickel plating	1
③	Tip Spring	② Copper Alloy, Silver plating	1
④	Terminal	Copper Alloy	1
⑤	Shield Plate	Stainless Steel	1
⑥	Ground Terminal	E Copper Alloy, Nickel plating	1

#### Ordering Grid

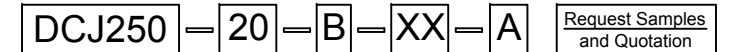

#### Circuit Diagram

B = 2 Conductors/2 Contacts

Insulator Colour

K1 = Black (Standard)

O1 = Orange (157C)

#### Packing

A = Tape & Reel  
(200 per reel)

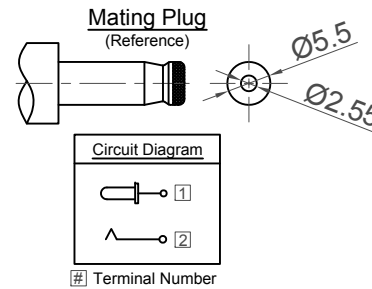

Part Number DCJ250-20		Product Description DC Power Jack, Thru-Hole, Horizontal, Shielded w/ Locating Peg, Ø2.50mm Pin mates with Ø2.55mm Plug						
Drawing Date 8th December 2015								
By Detail	AJO Drawing Release	Tolerances (Except as Noted) Length: ± 0.3	Angle: ± 2°	Units: Metric (mm)	This drawing is confidential and copyright of Global Connector Technology, Ltd (GCT). This drawing must not be copied or disclosed without written consent. E & OE			
Revision Date	A 08/12/15							Global Connector Technology www.gct.co

Part Number	Pcs/Reel	Reels/Carton	Cartons/Box	Pcs/Box
DCJ250-20	200	2	5	2000

Fig 1.

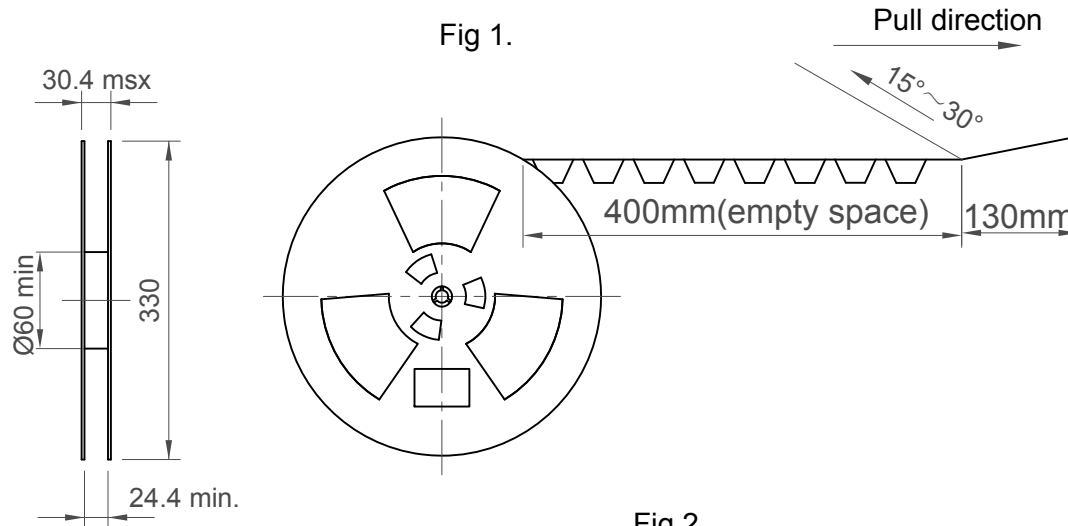

Fig 2.

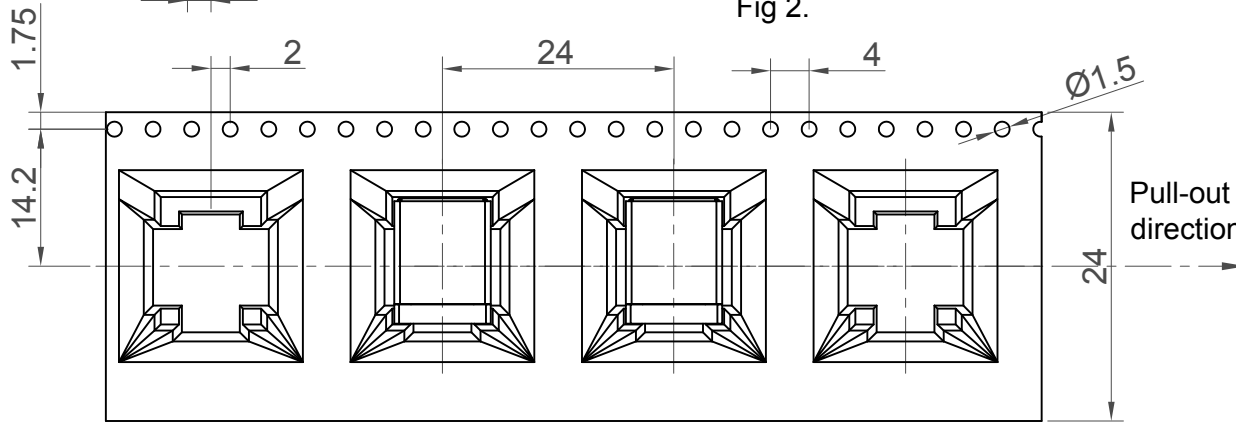
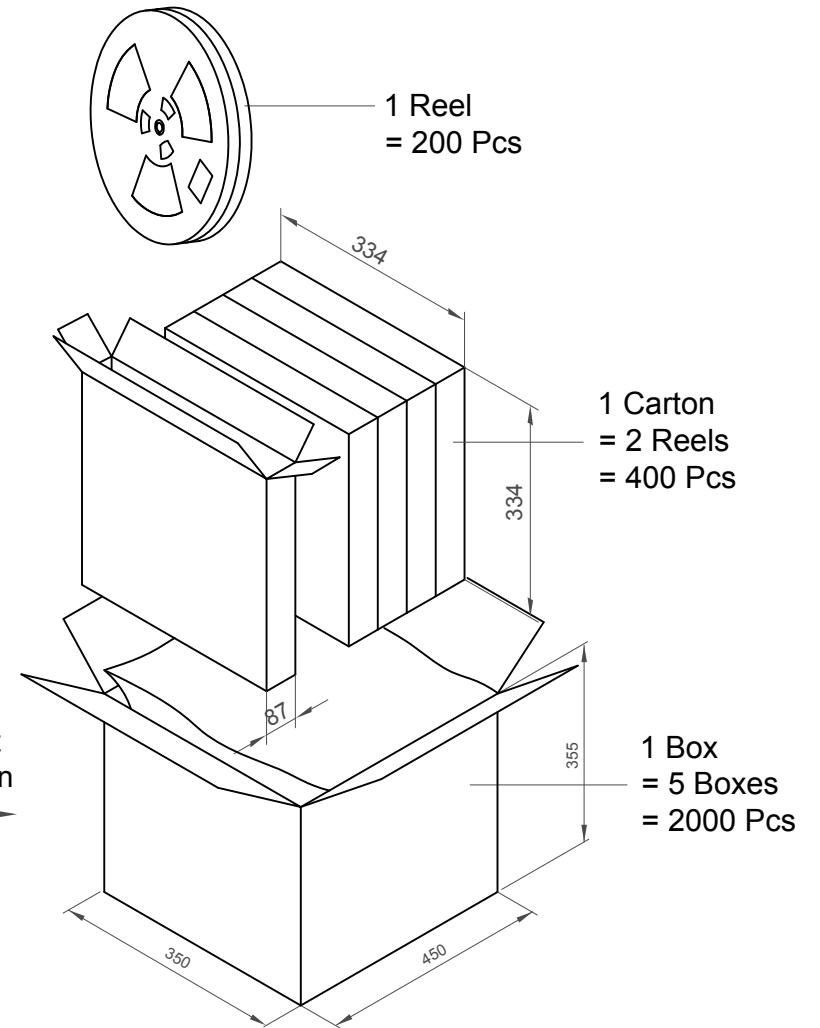

Fig 3.



**REMARK:**

- 1.The connector can not be loaded on the position of length 240~360mm in the reel tape and lead tape. The cover tape with 20~30mm length shall not be adhesive on the lead tape and the cover tape is lead portion shall have 150~200mm length (Refer FIG 1).
- 2.Tape shall turn on right direction.
- 3.The direction of connector is fixed regarding the position of terminal, please refer outline drawing (Refer FIG 2).
- 4.After winding, using the adhesive tape (30~50mm) to stick the leader of cover tape on the side of reel.
- 5.One reel can be loaded 200 pcs connector.
- 6.The label shall be pasted on the front side of reel (Refer FIG 3).
- 7.Condition of 300mm per minute, the extraction strength of cover tape shall reach 20~150 gf.
- 8.If the quantity is less than 6 reels per carton, the packing shall be able to resist shaking.

Part Number		Product Description	
DCJ250-20		DC Power Jack, Thru-Hole, Horizontal, Shielded w/ Locating Peg, Ø2.50mm Pin mates with Ø2.55mm Plug	
Drawing Date		8th December 2015	
By	AJO	Tolerances (Except as Noted)	Units: Metric (mm)
Detail	Drawing Release	Length	Angle
Revision	A	3rd Angle Projection	
Date	08/12/15		
This drawing is confidential and copyright of Global Connector Technology, Ltd (GCT). This drawing must not be copied or disclosed without written consent. E & OE			
Global Connector Technology www.gct.co		Not to Scale	Sheet No. 2/2