

DO NOT SCALE DRAWING

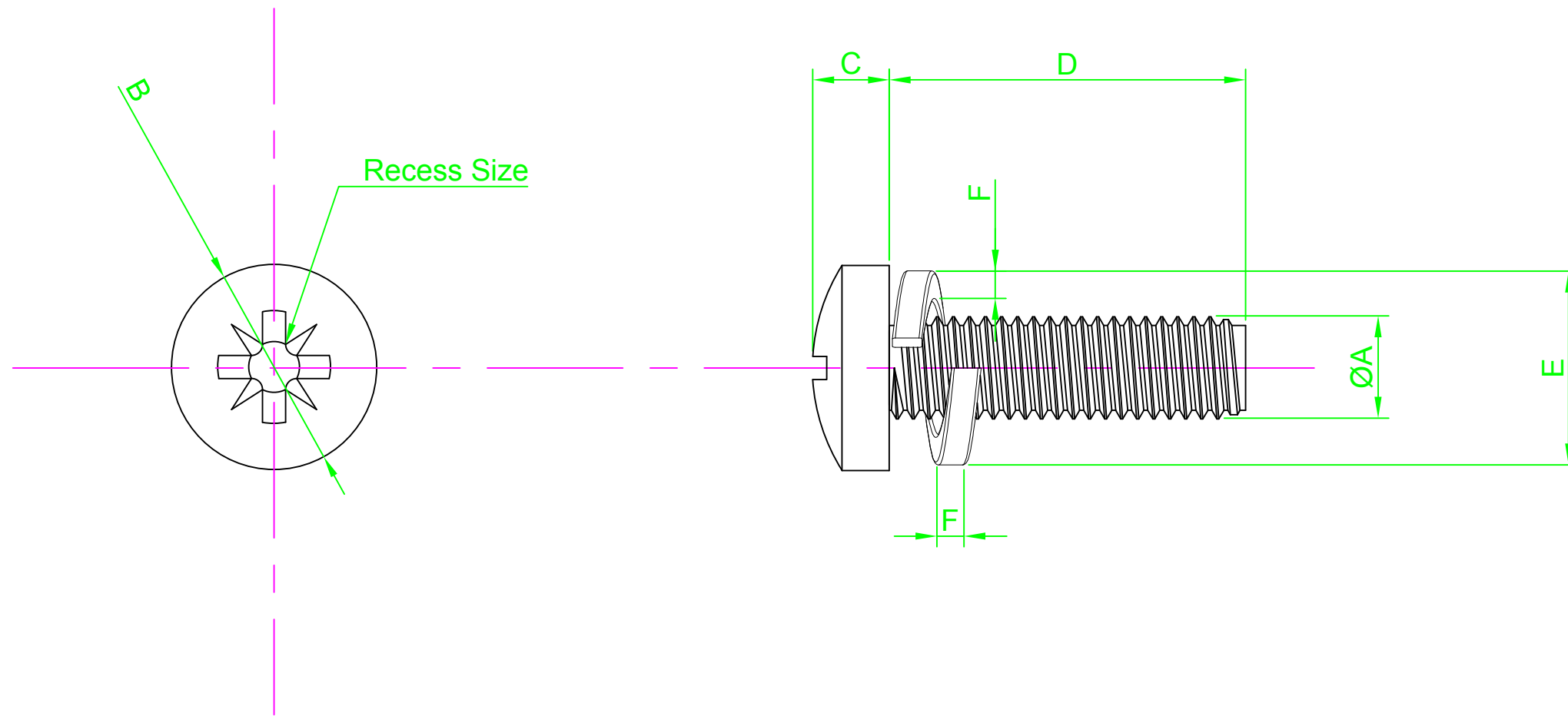

REVISION

A INITIAL DRAWING 28.9.15

Part Number	ØA	B Max	C Max	Recess Size	D Length Ref	E	F
M3 6 PRSTSS Z100	M3-0.5	5.7 - 6.0	1.96 - 2.10	Pozi #1	6.0	5.50	1.0
M3 12 PRSTSS Z100					12.0		
M4 12 PRSTSS Z100	M4-0.7	7.64 - 8.0	2.66 - 2.80	Pozi #2	12.0	6.95	1.2

NOTES:



UNLESS OTHERWISE SPECIFIED:
DIMENSIONS ARE IN MM (MILLIMETERS).
SURFACE FINISH:
TOLERANCES:

	NAME	DATE
DRAWN	Darryl Wilson	28.09.15
CHK'D		
APPVD		

MATERIAL:
Steel

HEAT TREATMENT:

TITLE:
Pozi Pan Head Machine Screw c/w
SEMS Square Section Spring Washer

DESIGN RIGHT. TR FASTENINGS LTD, 2003
UNDER NO CIRCUMSTANCES MUST THIS
DRAWING BE COPIED OR DISCLOSED
WITHOUT FIRST OBTAINING WRITTEN
AUTHORITY.

CUSTOMER PART NUMBER:
N/A

FINISH:
TC1 - Commercial Zinc/Clear Trivalent

DRAWING NUMBER:
TR32PRSTSS

A4

PROJECTION

