

- PINS TO COMPLY WITH AMP SOLDERABILITY SPEC. 108-11-3.
- 0.00381 MIN MATTE TIN LEAD OVER 0.00127 MIN NICKEL.
- 0.00076 MIN GOLD PLATE IN THE LOCALIZED PLATE AREA, 0.00381 MATTE TIN LEAD IN THE LOCALIZED PLATE AREA, BOTH OVER 0.00127 MIN NICKEL.
- 0.00381 MIN MATTE TIN OVER 0.00127 MIN NICKEL.
- 0.00076 MIN GOLD PLATE IN THE LOCALIZED PLATE AREA, 0.00381 MATTE TIN IN THE LOCALIZED PLATE AREA, BOTH OVER 0.00127 MIN NICKEL.

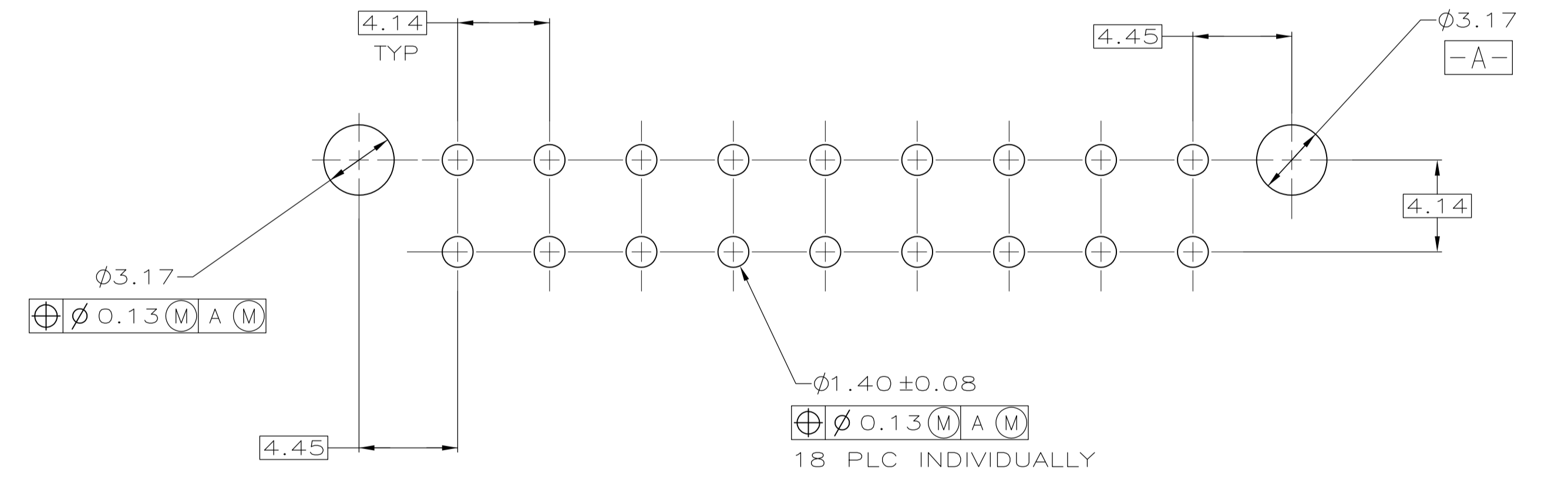

RECOMMENDED MOUNTING HOLE PATTERN FOR 1.57 THICK P.C. BOARD

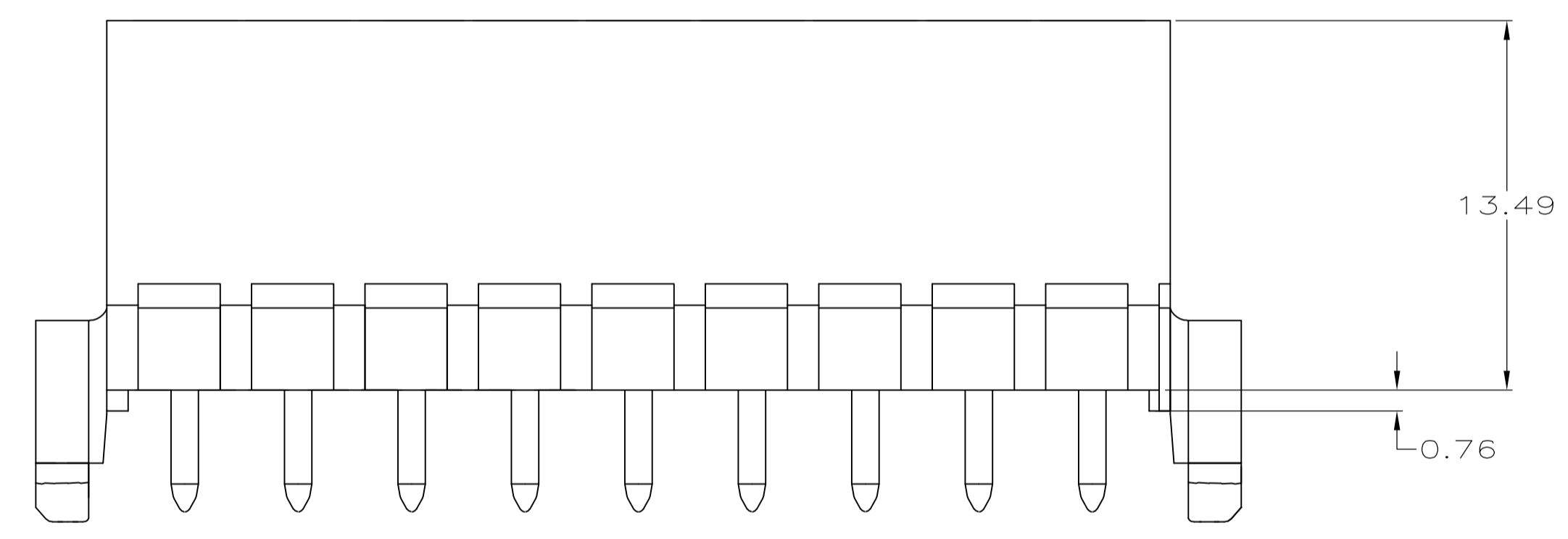
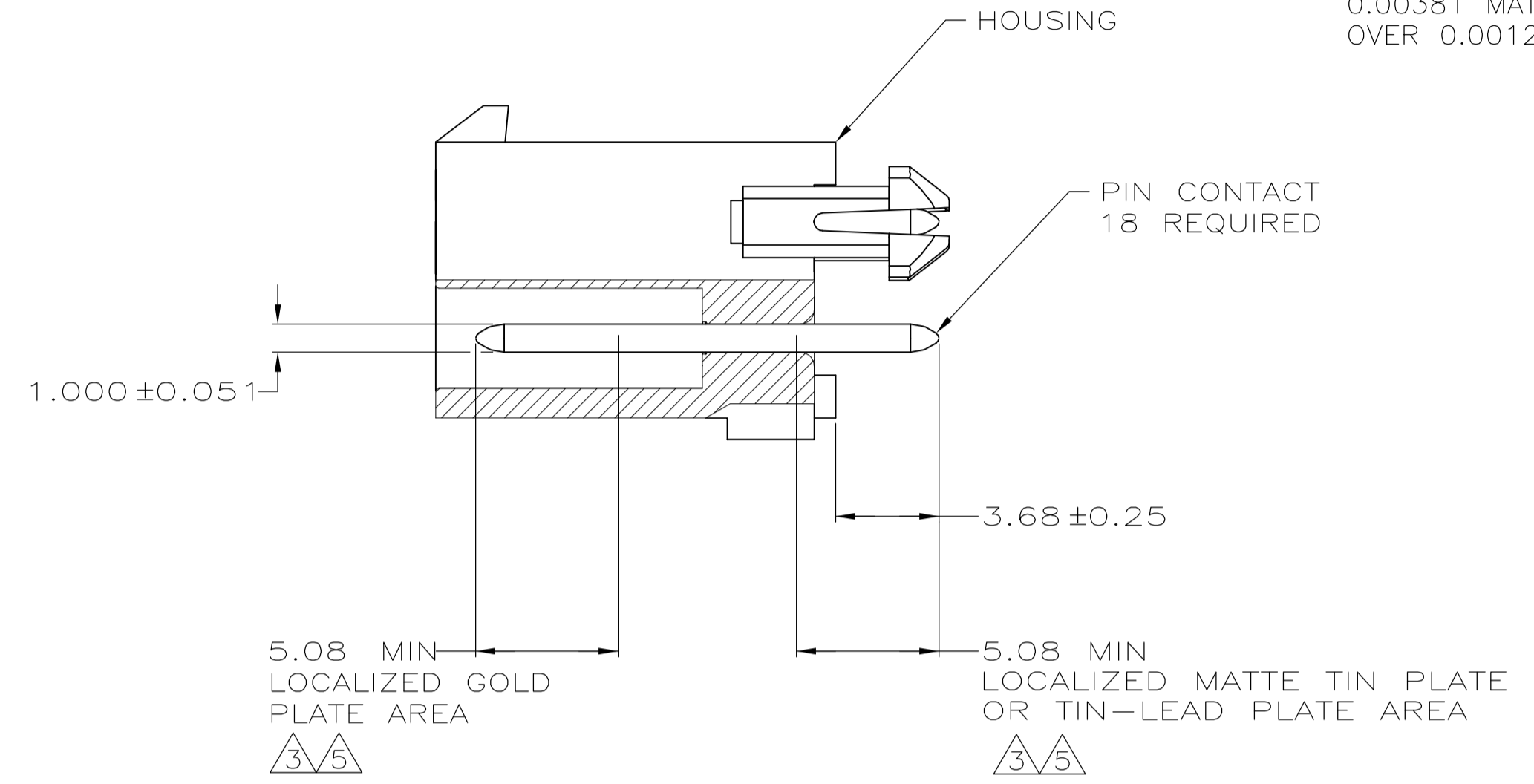
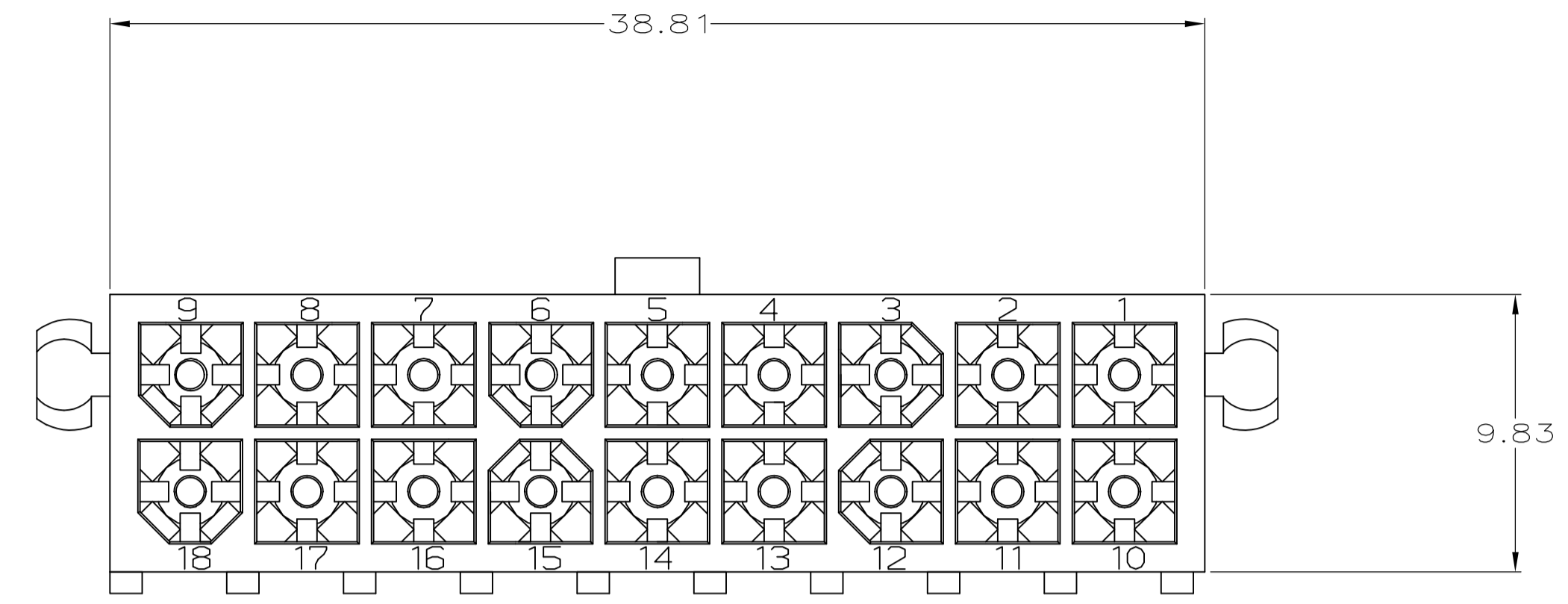
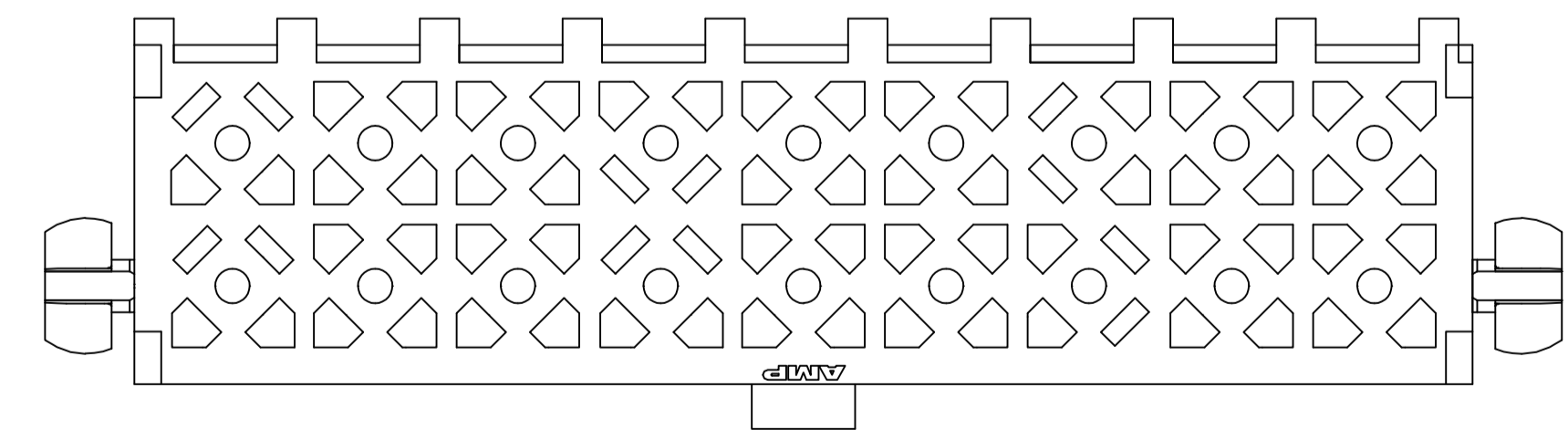

BRASS, GOLD	NYLON, 94V-0, WHITE	1-794069-1
BRASS, TIN	NYLON, 94V-0, WHITE	1-794069-0
BRASS, GOLD	NYLON, 94V-0, WHITE	794069-2
BRASS, TIN LEAD	NYLON, 94V-0, WHITE	794069-1
PIN CONTACT MATERIAL AND FINISH		PART NUMBER

THIS DRAWING IS A CONTROLLED DOCUMENT.

DIMENSIONS: mm	TOLERANCES UNLESS OTHERWISE SPECIFIED:	DIN K WHITAKER 6-09-95	CHK R SWING 6-09-95	APVD R ORSTAD 6-13-95	NAME	
0 PLC ± -	1 PLC ± -	TE Connectivity HEADER ASSEMBLY, 18 CIRCUIT, DOUBLE ROW VERTICAL, MINI-UNIVERSAL MATE-N-LOK			SIZE	
2 PLC ± 0.13	3 PLC ± -				APPLICATION SPEC	RESTRICTED TO
4 PLC ± -	ANGLES ± -				WEIGHT	SCALE
MATERIAL SEE TABLE	FINISH SEE TABLE				CUSTOMER DRAWING	SCALE 5:1

WEIGHT: -
 SIZE: A1
 CAGE CODE: 00779
 DRAWING NO: 794069
 SHEET 1 OF 1
 REV E