

ITEM	Q'TY	PART NUMBER	PART DESCRIPTION
1	1	PM5-3	LED Holder, 3-Lead Panel Mount, Press Fit, (5mm)
2	1	5BC-3-XX	T1 ¼ (5mm) 3-Lead Shouldered LED, See Page 2.
3	1	BWS24-1061-GN	24AWG Wire Lead U.L. 1061, Green
4	1	BWS24-1061-BK	24AWG Wire Lead U.L. 1061, Black
5	1	BWS24-1061-RD	24AWG Wire Lead U.L. 1061, Red
6	1	2665S030000	Leoco 2665 Series 2.54mm (100") Crimp Type Socket, 1X
7	3	2653TPB0001	Leoco Terminal# 2653TPB0001 (Reel) 2653TPB00A1(Bulk)

REV.	DESCRIPTION	DATE	APPROVED
A	Engineering Release	12/02/08	T. Y.
B	Updated 5BC-3 LED on Polarity Diagram	09/01/09	T. Y.
C	Added Optical/ Electrical Data	05/21/15	J. C.

Note: Connector Shipped Non-Assembled in Separate Bag

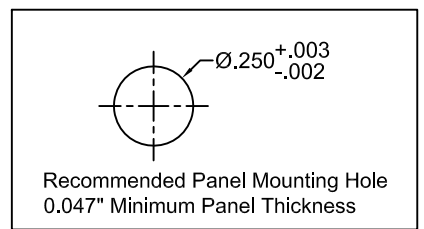
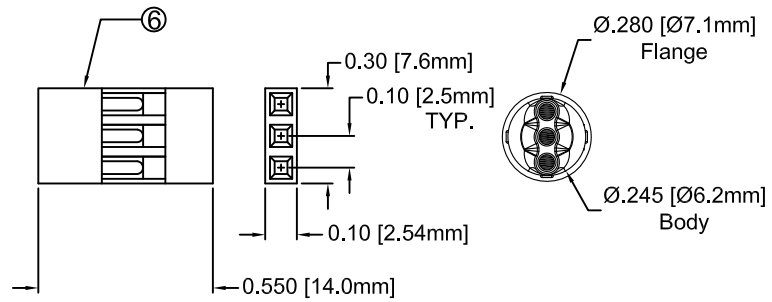
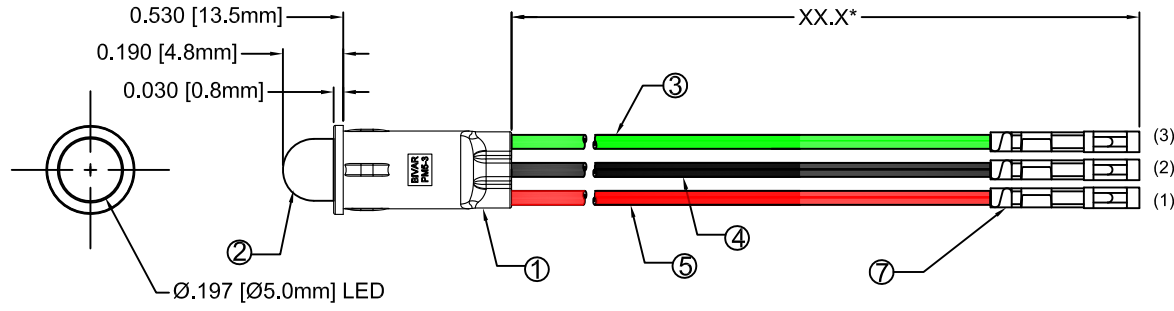

LED P/N	(1) Anode Red Wire	(2) Common Cathode Black Wire	(3) Anode Green Wire
5BC-3	Red		Green
5BC-3-Y/G	Yellow		Green
5BC-3-R/Y	Red		Yellow

EXAMPLE:
 PM53 - BC W12.5 CC
 Connector Assembly
 XX.X = Wire Length "XX.X*"
 Emitted Colors
 3-Lead Panel Mount Series

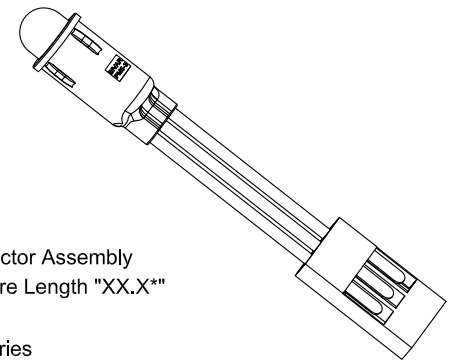

ABSOLUTE MAXIMUM RATINGS (Ta = 25°C)

REVERSE VOLTAGE _____ 5V
 REVERSE CURRENT (VR=5V) _____ 100µA
 OPERATING TEMPERATURE RANGE _____ -25°C ~ 85°C
 STORAGE TEMPERATURE _____ -30°C ~ 100°C
 LEAD SOLDERING TEMPERATURE (1/16" FROM BODY) _____ 260°C for 5 Seconds

STANDARD TOLERANCE (UNLESS OTHERWISE SPECIFIED)			4 THOMAS, IRVINE, CA. 92618 TEL: (949) 951-8808 FAX: (949) 951-3974	
DECIMALS	ANGULAR			
.X ± .1	X° ± 1°		TITLE: T1 ¼ (5mm) PANEL MOUNT ASSEMBLY, 3-LEAD BI-COLOR	
.XX ± .02				PART NO: PM53-XXWXX.XCC CAGE CODE : 32559 SHEET # 1 OF 2
.XXX ± .010				

CAD GENERATED DOCUMENT, DO NOT MEASURE DRAWING.

REV.	DESCRIPTION	DATE	APPROVED
	SEE SHEET#1.		

Assy. Part No.	Chip			Lens Appearance	Electro-Optical Data @ 20mA				Viewing Angle 2 θ ½ (Deg)	LED P/N
	Material	Peak Wave Length	Emitted Color		I _f (mA)	V _f (V)		I _v (mcd)		
					MAX	TYP	MAX	TYP		
PM53-BCWXX.XCC	GaAsP/GaP	625nm	RED	WHITE DIFFUSED	30	2.0	2.8	35	40	5BC-3
	GaP/GaP	568nm	GREEN		30	2.1	2.8	35		
PM53-YGWXX.XCC	GaAsP/GaP	590nm	YELLOW	WHITE DIFFUSED	30	2.0	2.8	30	40	5BC-3-Y/G
	GaP/GaP	568nm	GREEN		30	2.1	2.8	35		
PM53-RYWXX.XCC	GaAsP/GaP	625nm	RED	WHITE DIFFUSED	30	2.0	2.8	35	40	5BC-3-R/Y
	GaAsP/GaP	590nm	YELLOW		30	2.0	2.8	30		

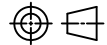
STANDARD TOLERANCE (UNLESS OTHERWISE SPECIFIED) ±10% ALL VALUES ANGULAR		 BIVAR [®] 4 THOMAS, IRVINE, CA. 92618 TEL: (949) 951-8808 FAX: (949) 951-3974	
		 TITLE: T1 ¼ (5mm) PANEL MOUNT ASSEMBLY, 3-LEAD BI-COLOR	
DESIGNED: Brian Oliver	DATE: 12/02/08	PART NO: PM53-XXWXX.XCC	REVISION: C
CHECKED: F. Jensen	DATE: 12/02/08	CAGE CODE : 32559	SHEET # 2 OF 2
CAD GENERATED DOCUMENT, DO NOT MEASURE DRAWING.			