

引き出し方向

PULL OUT  
DIRECTION

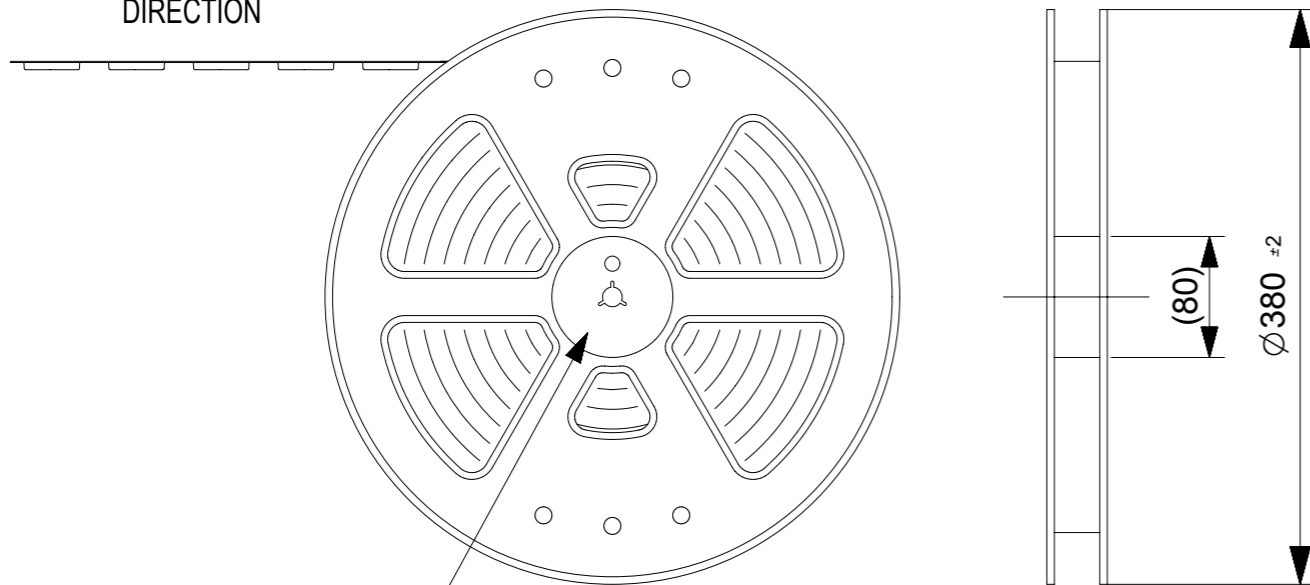

"E"

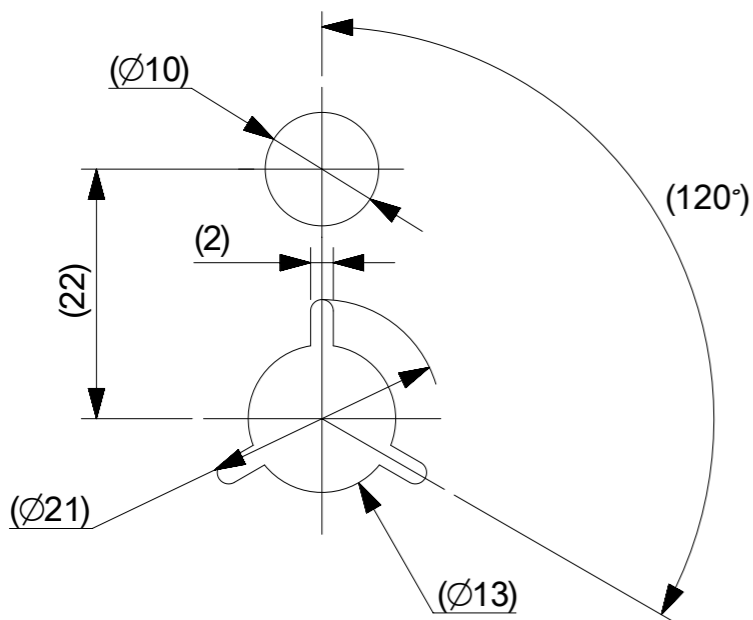

DETAIL "E"

NOTES

1. 梱包数量 : 3000個 / リール  
NUMBER OF CONNECTORS : 3000 PCS/REEL.
2. リードテープ長さ  
LEAD TAPE LENGTH

引き出し方向

PULL OUT  
DIRECTION

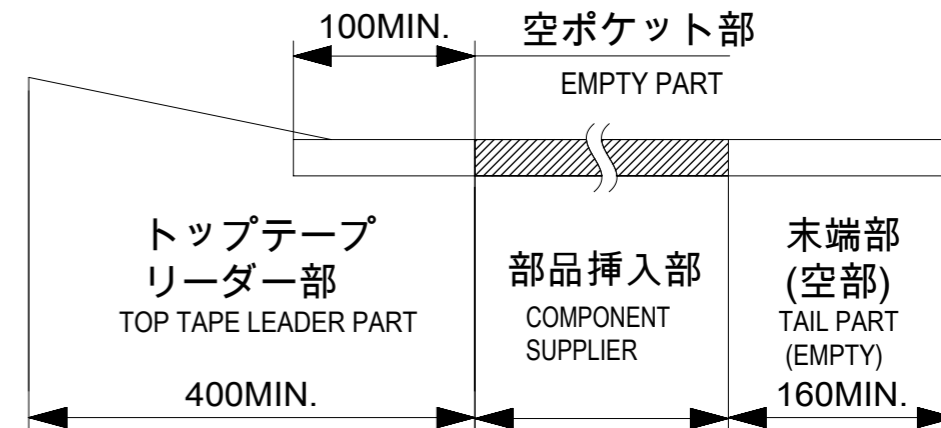

3. カバーテープの剥離強度については、IEC60286-3に準拠。  
COVER TAPE PEEL FORCE IS DEFINED BY IEC 60286-3.
4. 製品詳細寸法については、図面 2005291000-000を参照下さい。  
FOR DIMENTIONS OF PRODUCT, REFER TO 2005291000-000.
5. 材料 MATERIAL  
キャリアテープ : ポリスチレン  
CARRIER TAPE : POLYSTYRENE  
トップテープ : ポリエチレンテレフタレート、ポリエチレン  
TOP TAPE : POLYETHYLENE TEREHTHALATE, POLYETHYLENE  
リール : ポリスチレン<リサイクル材を含む>
6. ELV及びRoHS適合品 ELV AND RoHS COMPLIANT.

THIS DRAWING CONTAINS INFORMATION THAT IS PROPRIETARY TO MOLEX ELECTRONIC TECHNOLOGIES, LLC AND SHOULD NOT BE USED WITHOUT WRITTEN PERMISSION

REVISED	EC NO: 103009	2016/02/09	GENERAL TOLERANCES (UNLESS SPECIFIED)		DIMENSION UNITS	SCALE	<b>molex</b>			
	DRWN: MTAKAHASHI04	2016/02/19	ANGULAR TOL $\pm 1.0^\circ$		MM	2:1				
	CHK'D: KTAKAHASHI	2016/02/19	4 PLACES	$\pm 0.05$	DRWN BY	DATE	1.0 FPC ZIF BTM CONT EMBT PKG			
	APPR: TKUSUHARA01	2016/02/19	3 PLACES	$\pm 0.1$	MTAKAHASHI04	2015/12/24				
			2 PLACES	$\pm 0.2$	CHK'D BY	DATE	PRODUCT CUSTOMER DRAWING			
		1 PLACE	$\pm 0.2$	KTAKAHASHI	2015/12/25					
		0 PLACES	$\pm 0.2$	APPR BY	DATE	SERIES MATERIAL NUMBER CUSTOMER				
		DRAFT WHERE APPLICABLE MUST REMAIN WITHIN DIMENSIONS		YNOGAWA	2016/01/04					200529
				DRAWING SIZE	THIRD ANGLE PROJECTION	DOCUMENT NUMBER		DOC TYPE	DOC PART	SHEET NUMBER
				A3		2005290000		PSD	000	1 OF 2

引き出し方向  
PULL OUT  
DIRECTION

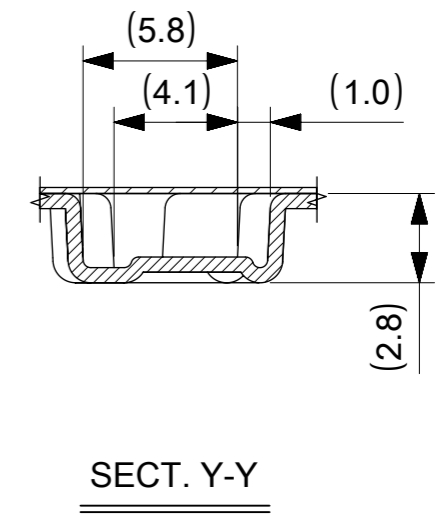
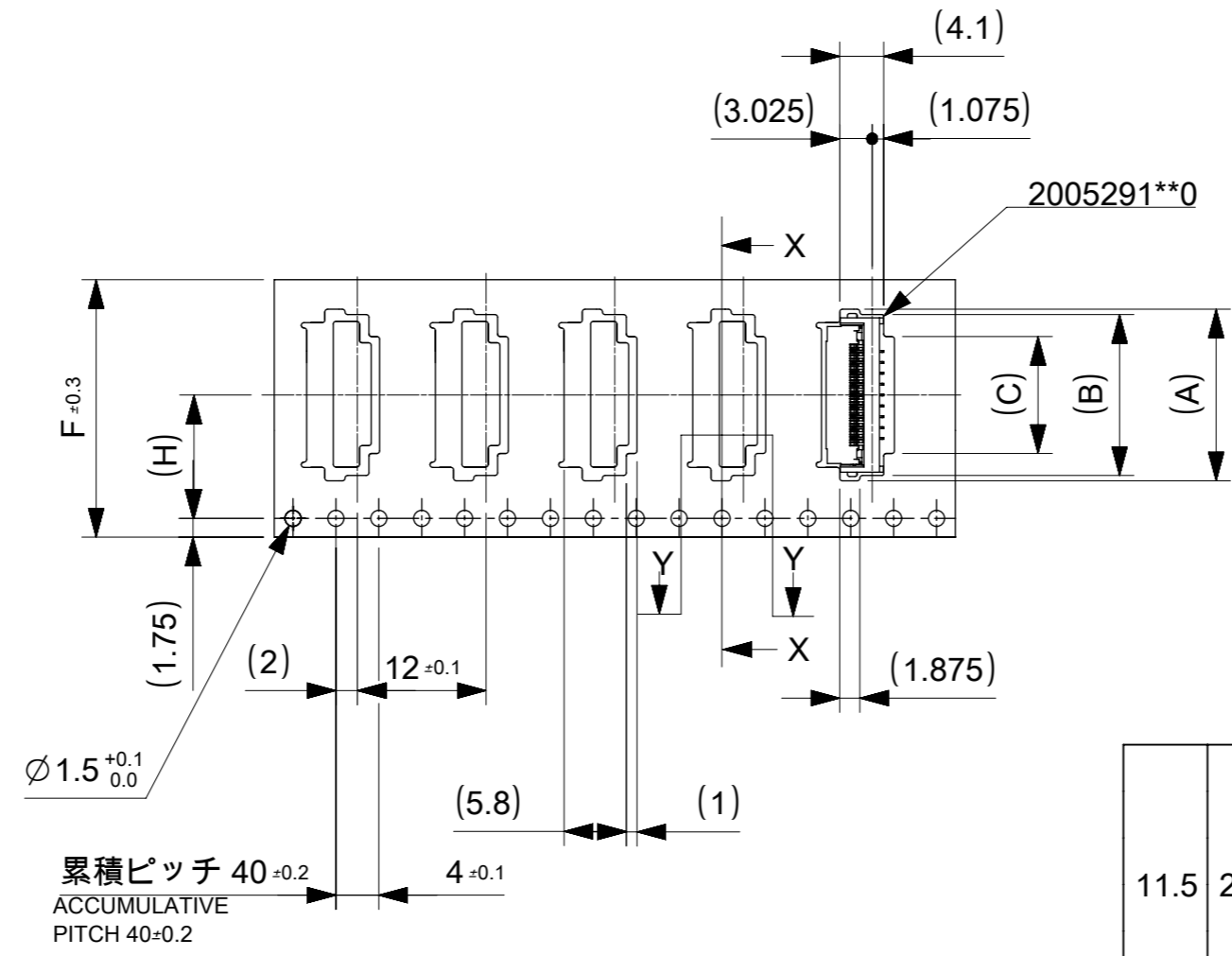
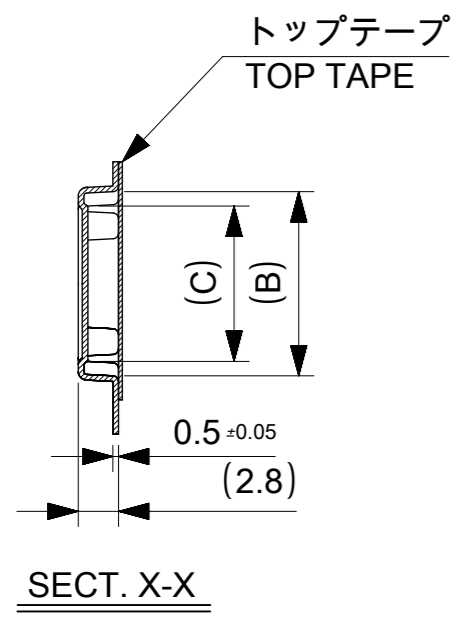

11.5	24	29.4	25.4	10.4	14.4	15.5	2005290090	9
				9.4	13.4	14.5	2005290080	8
				8.4	12.4	13.5	2005290070	7
				7.4	11.4	12.5	2005290060	6
				6.4	10.4	11.5	2005290050	5
				5.4	9.4	10.5	2005290040	4
H	F	E	D	C	B	A	EMBOSSED PACKAGE	Ckt
オーダー番号 ORDER NO.								
CONNECTER NO. 2005291**0								

THIS DRAWING CONTAINS INFORMATION THAT IS PROPRIETARY TO MOLEX ELECTRONIC TECHNOLOGIES, LLC AND SHOULD NOT BE USED WITHOUT WRITTEN PERMISSION

EC NO: 103009 DRWN: MTAKAHASHI04 CHK'D: KTAKAHASHI APPR: TKUSUHARA01	2016/02/09	2016/02/19	2016/02/19	GENERAL TOLERANCES (UNLESS SPECIFIED)  ANGULAR TOL ± 1.0 °  4 PLACES ± 0.05 3 PLACES ± 0.1 2 PLACES ± 0.2 1 PLACE ± 0.2 0 PLACES ± 0.2  DRAFT WHERE APPLICABLE MUST REMAIN WITHIN DIMENSIONS	DIMENSION UNITS	SCALE	
	REVISED	MM	1:1				
	DRWN BY	DATE	MTAKAHASHI04		2015/12/24		
	CHK'D BY	DATE	KTAKAHASHI		2015/12/25		
	APPR BY	DATE	YNOGAWA		2016/01/04		
	DRAWING SIZE	THIRD ANGLE PROJECTION					PRODUCT CUSTOMER DRAWING
	A3			SERIES	MATERIAL NUMBER	CUSTOMER	1.0 FPC ZIF BTM CONT EMBT PKG
				200529	SEE CHART	GENERAL	
				DOCUMENT NUMBER	DOC TYPE	DOC PART	SHEET NUMBER
				2005290000	PSD	000	2 OF 2

引き出し方向

PULL OUT  
DIRECTION

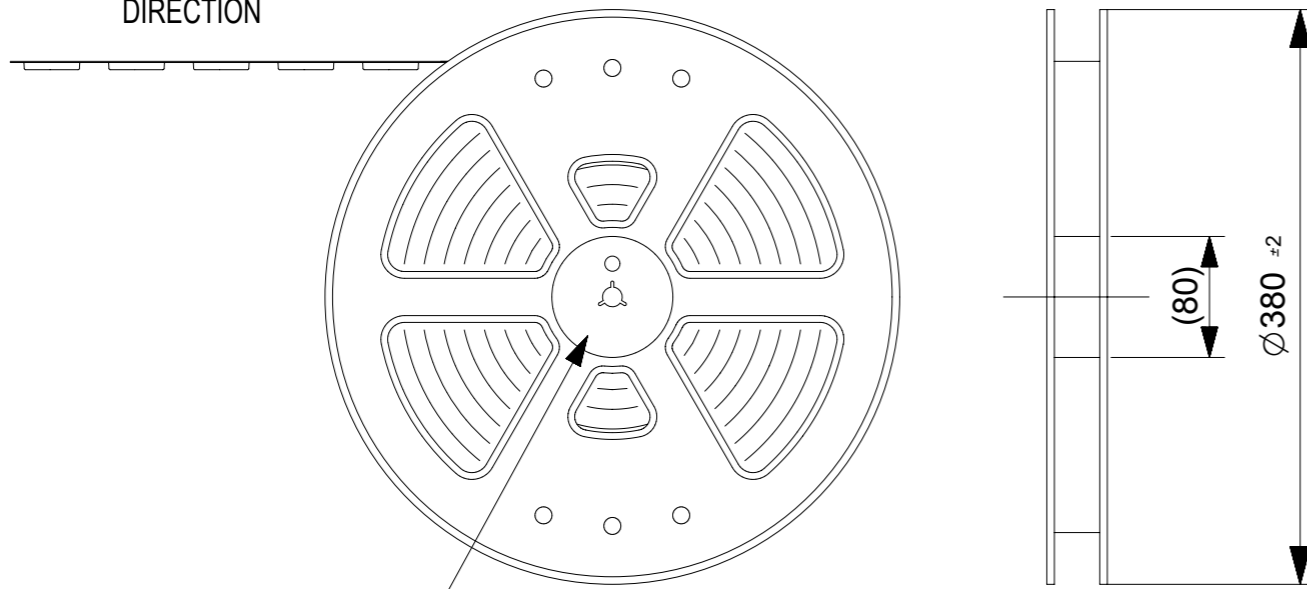

"E"

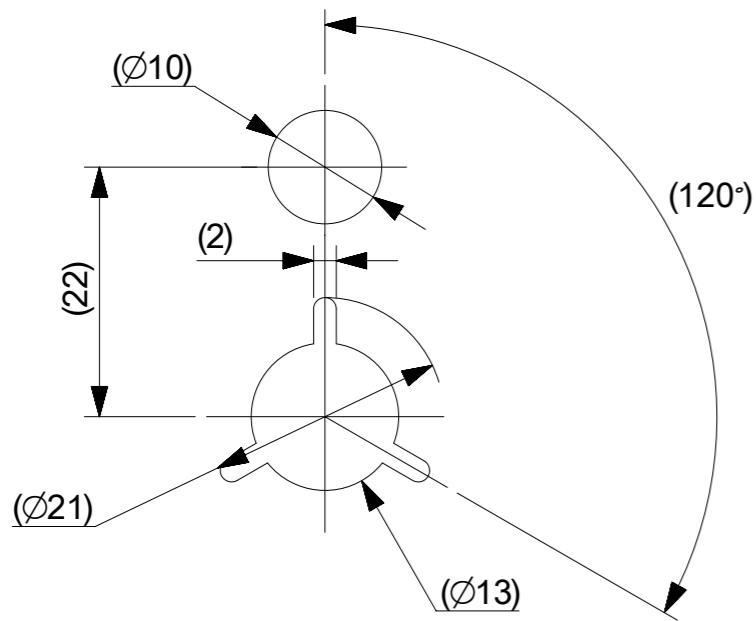

DETAIL "E"

NOTES

- 梱包数量 : 3000個 / リール  
NUMBER OF CONNECTORS : 3000 PCS/REEL.
  - リードテープ長さ  
LEAD TAPE LENGTH
- 
- カバーテープの剥離強度については、IEC60286-3に準拠。  
COVER TAPE PEEL FORCE IS DEFINED BY IEC 60286-3.
  - 製品詳細寸法については、図面 2005291006-000を参照下さい。  
FOR DIMENTIONS OF PRODUCT, REFER TO 2005291006-000.
  - 材料 MATERIAL  
キャリアテープ : ポリスチレン  
CARRIER TAPE : POLYSTYRENE  
トップテープ : ポリエチレンテレフタレート、ポリエチレン  
TOP TAPE : POLYETHYLENE TEREHTHALATE, POLYETHYLENE  
リール :ポリスチレン<リサイクル材を含む>
  - ELV及びRoHS適合品 ELV AND RoHS COMPLIANT.

THIS DRAWING CONTAINS INFORMATION THAT IS PROPRIETARY TO MOLEX ELECTRONIC TECHNOLOGIES, LLC AND SHOULD NOT BE USED WITHOUT WRITTEN PERMISSION

REVISED	EC NO: 103009	2016/02/09	GENERAL TOLERANCES (UNLESS SPECIFIED)	DIMENSION UNITS	SCALE	<b>molex</b>			
	DRWN: MTAKAHASHI04	2016/02/19	ANGULAR TOL ± 1.0 °	MM	2:1				
	CHK'D: KTAKAHASHI	2016/02/19	4 PLACES ± 0.05	DRWN BY	DATE	PRODUCT CUSTOMER DRAWING			
	APPR: TKUSUHARA01		3 PLACES ± 0.1	MTAKAHASHI04	2015/12/24				
			2 PLACES ± 0.2	CHK'D BY	DATE	DOCUMENT NUMBER DOC TYPE DOC PART SHEET NUMBER 2005290006 PSD 000 1 OF 2			
		1 PLACE ± 0.2	KTAKAHASHI	2015/12/25					
		0 PLACES ± 0.2	APPR BY	DATE					
			YNOGAWA	2016/01/04					
			DRAFT WHERE APPLICABLE MUST REMAIN WITHIN DIMENSIONS	DRAWING SIZE	THIRD ANGLE PROJECTION				
				A3					

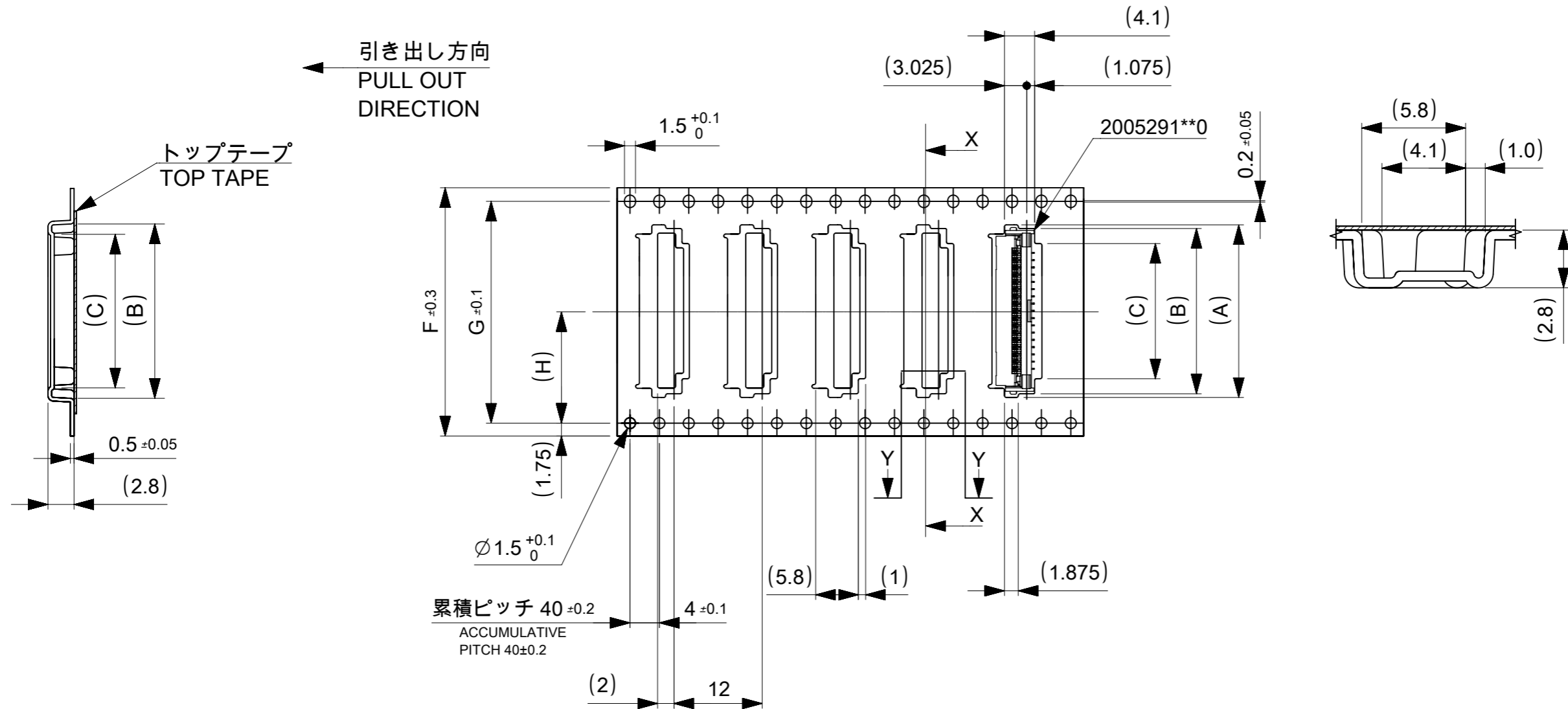

20.2	40.4	44	49.4	45.4	23.4	27.4	28.5	2005290220	22
					18.4	22.4	23.5	2005290170	17
H	G	F	E	D	C	B	A	EMBOSSED PACKAGE	Ckt
								オーダー番号 ORDER NO.	

CONNECTOR SERIES NO. 2005291\*\*0

THIS DRAWING CONTAINS INFORMATION THAT IS PROPRIETARY TO MOLEX ELECTRONIC TECHNOLOGIES, LLC AND SHOULD NOT BE USED WITHOUT WRITTEN PERMISSION

EC NO: 103009 DRWN: MTAKAHASHI04 CHK'D: KTAKAHASHI APPR: TKUSUHARA01	2016/02/09	2016/02/19	2016/02/19	GENERAL TOLERANCES (UNLESS SPECIFIED) ANGULAR TOL ± 1.0 ° 4 PLACES ± 0.05 3 PLACES ± 0.1 2 PLACES ± 0.2 1 PLACE ± 0.2 0 PLACES ± 0.2 DRAFT WHERE APPLICABLE MUST REMAIN WITHIN DIMENSIONS	DIMENSION UNITS	SCALE				
	REVISED				MM	2:1				
					DRWN BY	DATE		MTAKAHASHI04 2015/12/24		
					CHK'D BY	DATE		KTAKAHASHI 2015/12/25		
					APPR BY	DATE		YNOGAWA 2016/01/04		
			DRAWING SIZE	THIRD ANGLE PROJECTION	A3		PRODUCT CUSTOMER DRAWING			
							SERIES	MATERIAL NUMBER	CUSTOMER	
							200529	SEE CHART	GENERAL	
							DOCUMENT NUMBER	DOC TYPE	DOC PART	SHEET NUMBER
							2005290006	PSD	000	2 OF 2

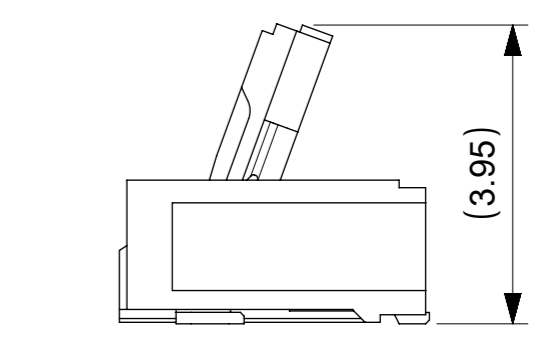
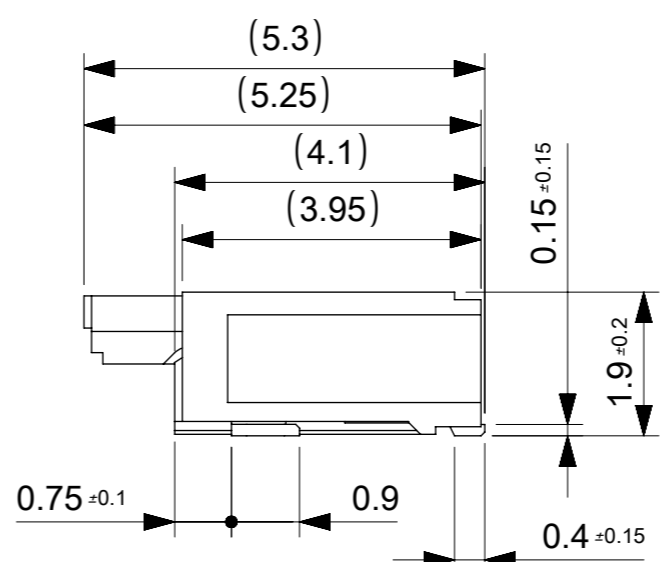
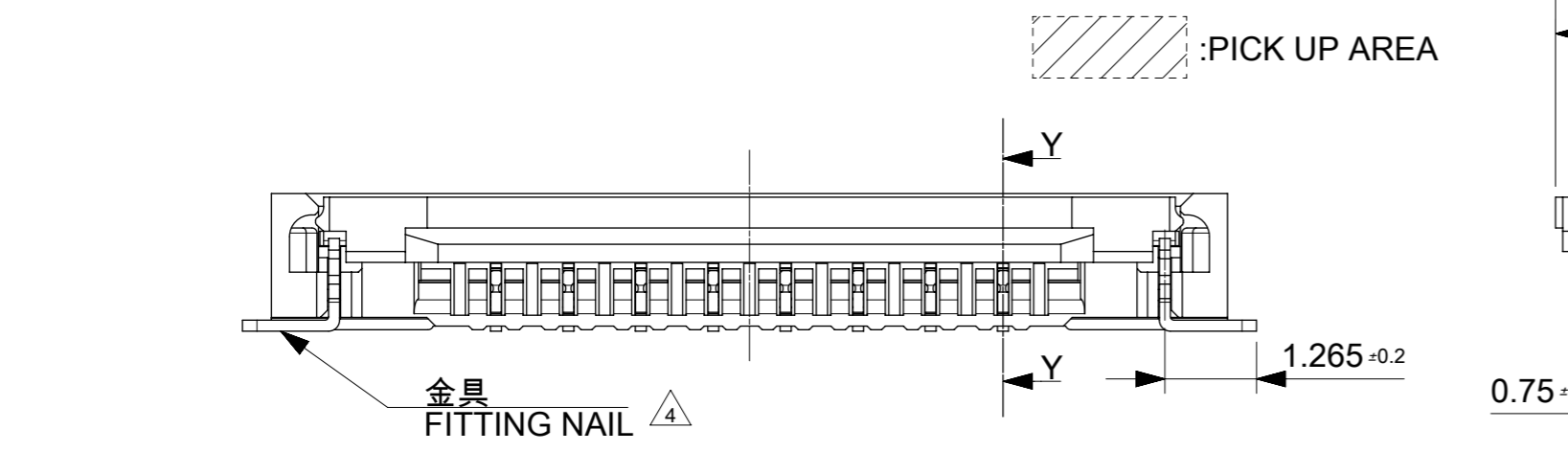
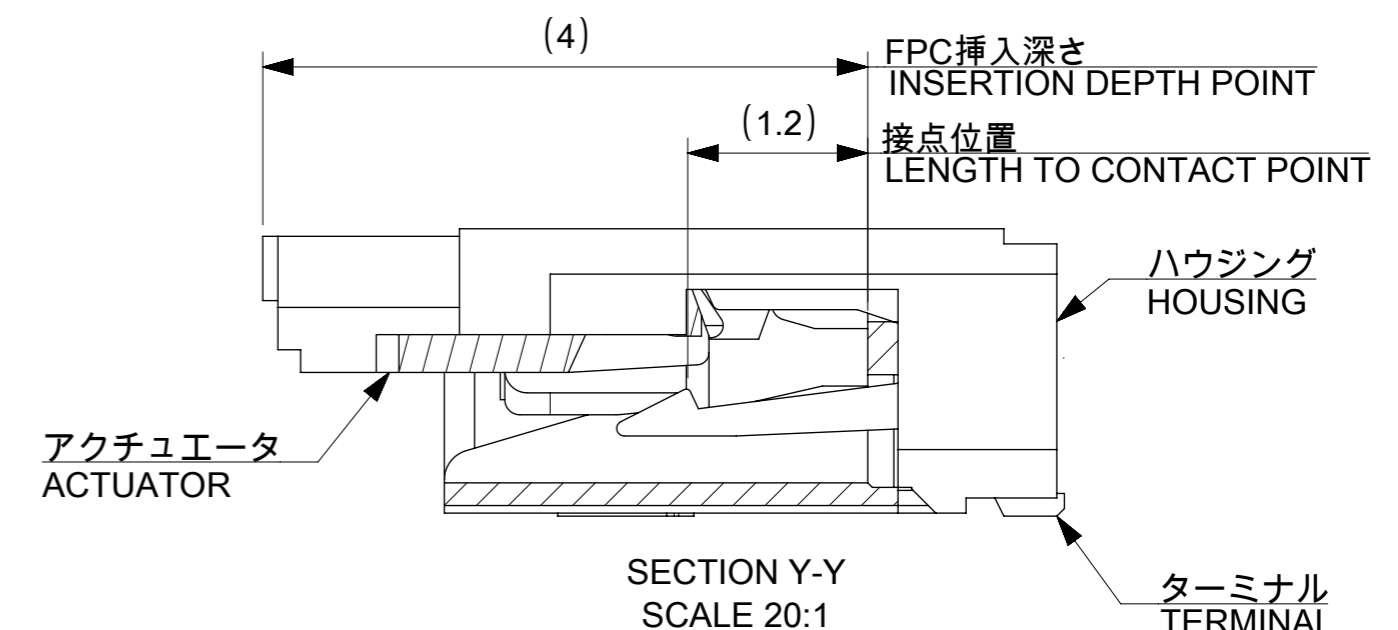
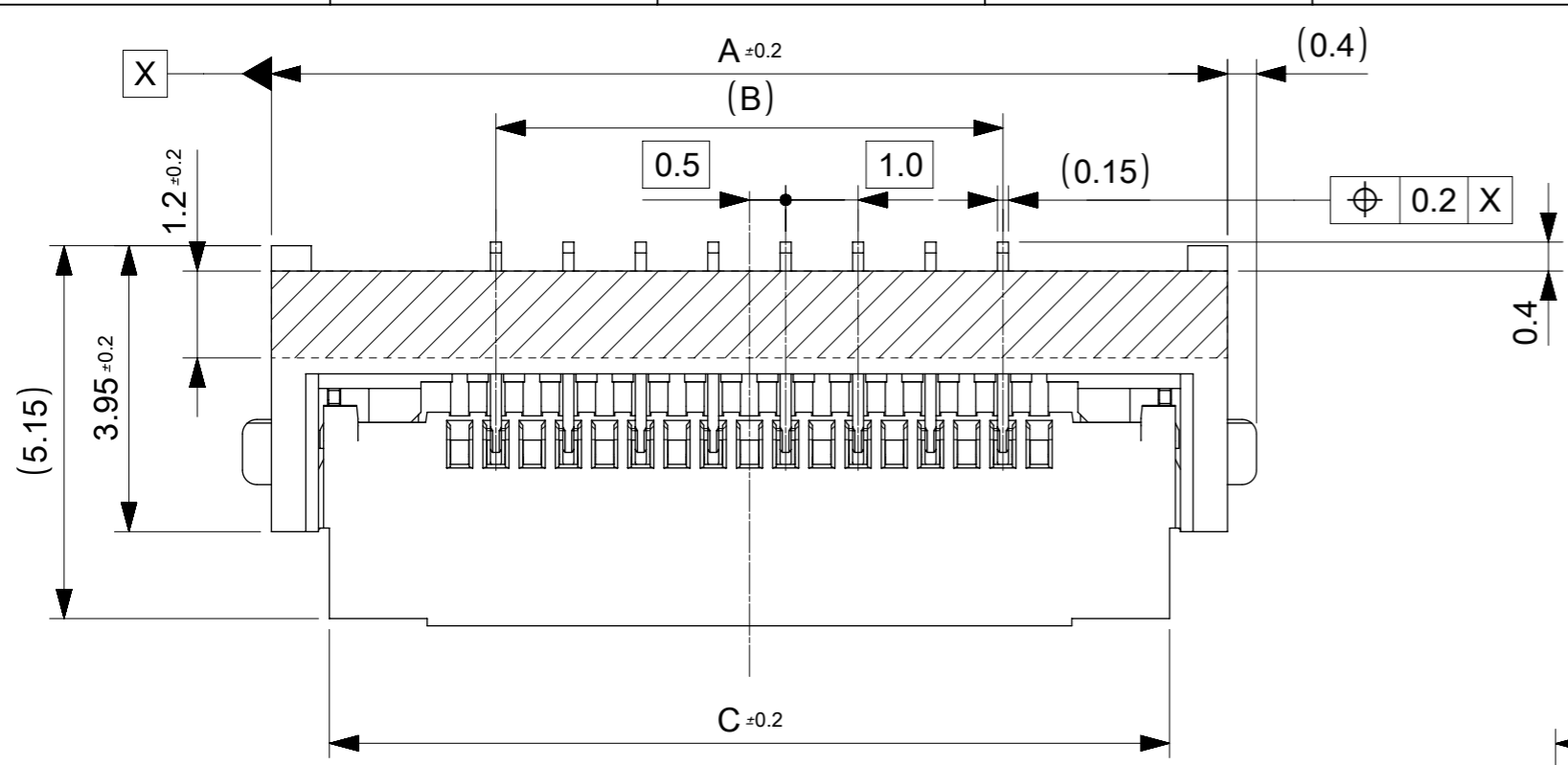

12.6	8.0	14.2	2005290090	9
11.6	7.0	13.2	2005290080	8
10.6	6.0	12.2	2005290070	7
9.6	5.0	11.2	2005290060	6
8.6	4.0	10.2	2005290050	5
7.6	3.0	9.2	2005290040	4
C	B	A	EMBOSSED PACKAGE オーダー番号 ORDER NO.	Ckt

CONNECTOR SERIES NO.2005291\*\*0

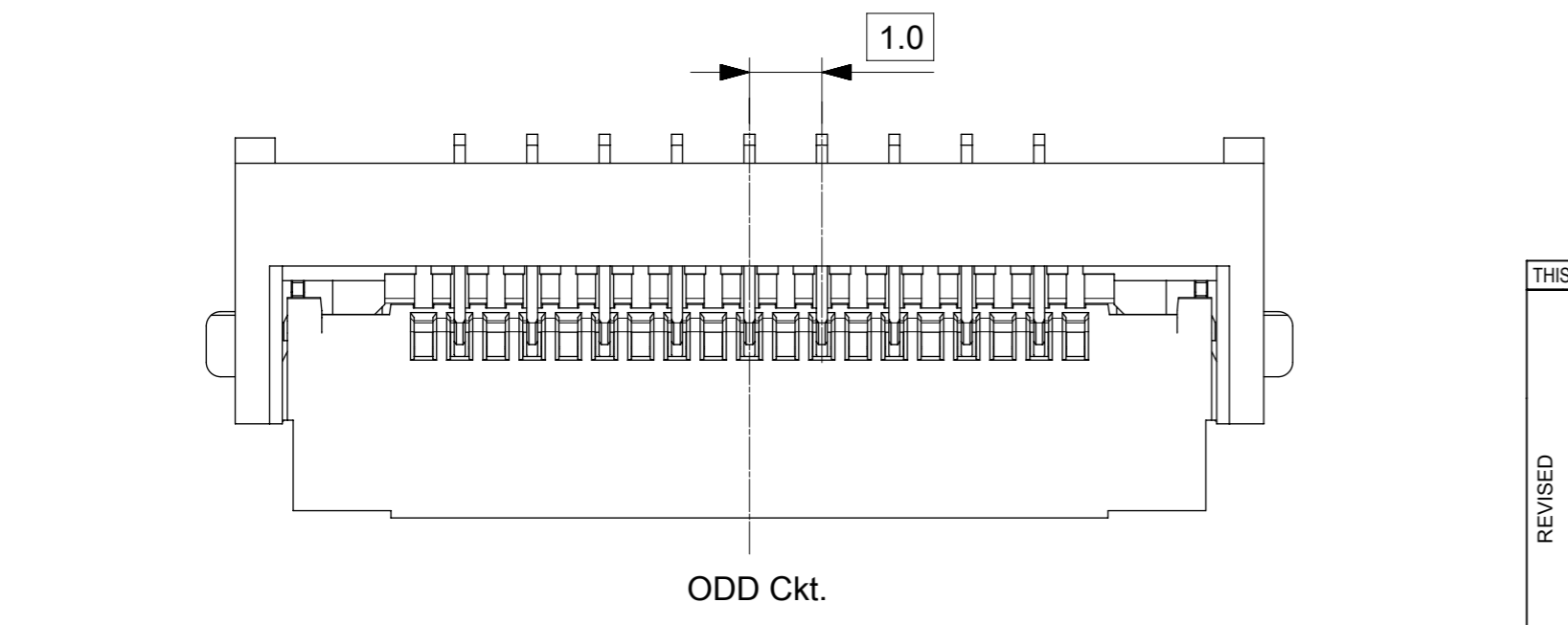

THIS DRAWING CONTAINS INFORMATION THAT IS PROPRIETARY TO MOLEX ELECTRONIC TECHNOLOGIES, LLC AND SHOULD NOT BE USED WITHOUT WRITTEN PERMISSION

REVISED	2016/02/09	GENERAL TOLERANCES (UNLESS SPECIFIED)	DIMENSION UNITS	SCALE	
	2016/02/19	ANGULAR TOL ± 1.0 °	MM	10:1	
	2016/02/19	4 PLACES ± 0.05	DRWN BY	DATE	
		3 PLACES ± 0.1	MTAKAHASHI04	2015/12/24	
EC NO: 103009	DRWN: MTAKAHASHI04	2 PLACES ± 0.2	CHK'D BY	DATE	<p>1.0 FPC ZIF BTM CONT HSG ASSY</p> <p>PRODUCT CUSTOMER DRAWING</p>
	CHK'D: KTAKAHASHI	1 PLACE ± 0.2	KTAKAHASHI	2015/12/25	
	REVISION #	0 PLACES ± 0.2	APPR BY	DATE	
	DATE: 2015/11/16		YNOGAWA	2016/01/04	
		DRAFT WHERE APPLICABLE MUST REMAIN WITHIN DIMENSIONS	DRAWING SIZE	THIRD ANGLE PROJECTION	<p>SERIES: 200529</p> <p>MATERIAL NUMBER: SEE CHART</p> <p>CUSTOMER: GENERAL</p>
			A3		<p>DOCUMENT NUMBER: 2005291000</p> <p>DOC TYPE: PSD</p> <p>DOC PART: 000</p> <p>SHEET NUMBER: 1 OF 3</p>

適合FPC/FFC推奨寸法  
APPLICABLE FPC/FFC  
RECOMMENDED DIMENSION

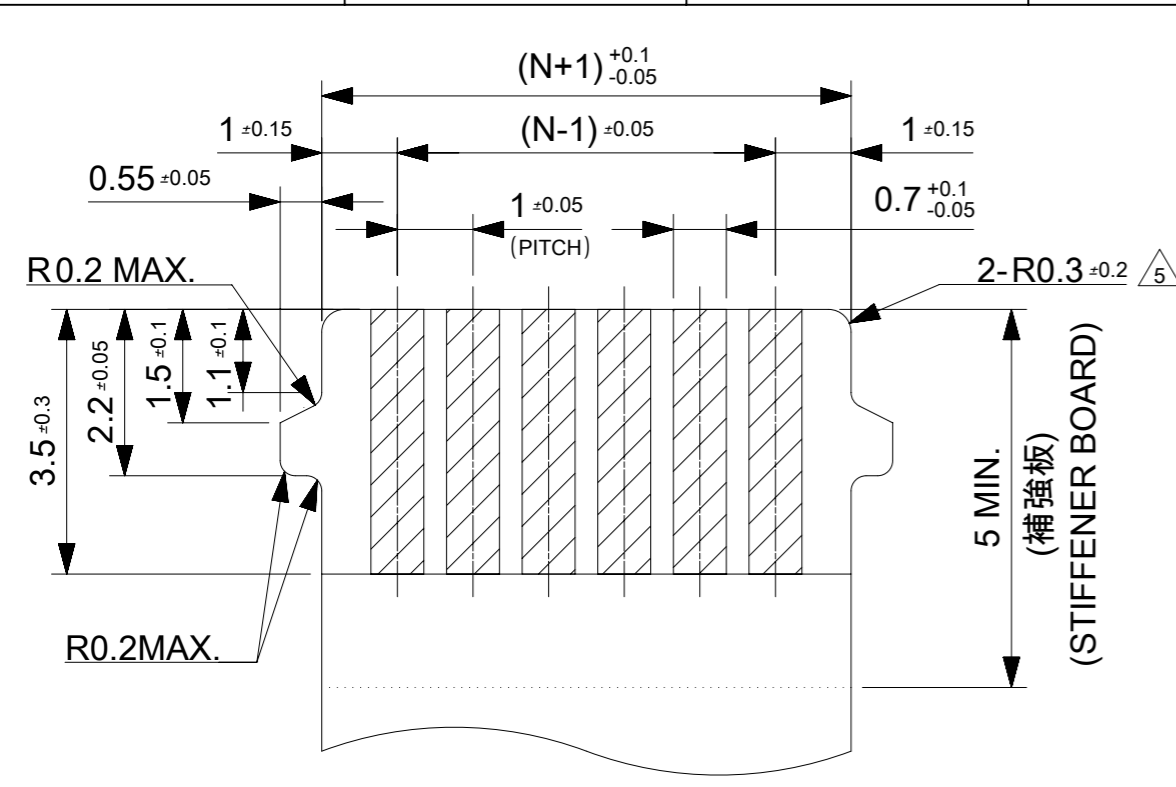

耳無し適合FPC/FFC推奨寸法  
APPLICABLE NON-TAB FPC/FFC  
RECOMMENDED DIMENSION

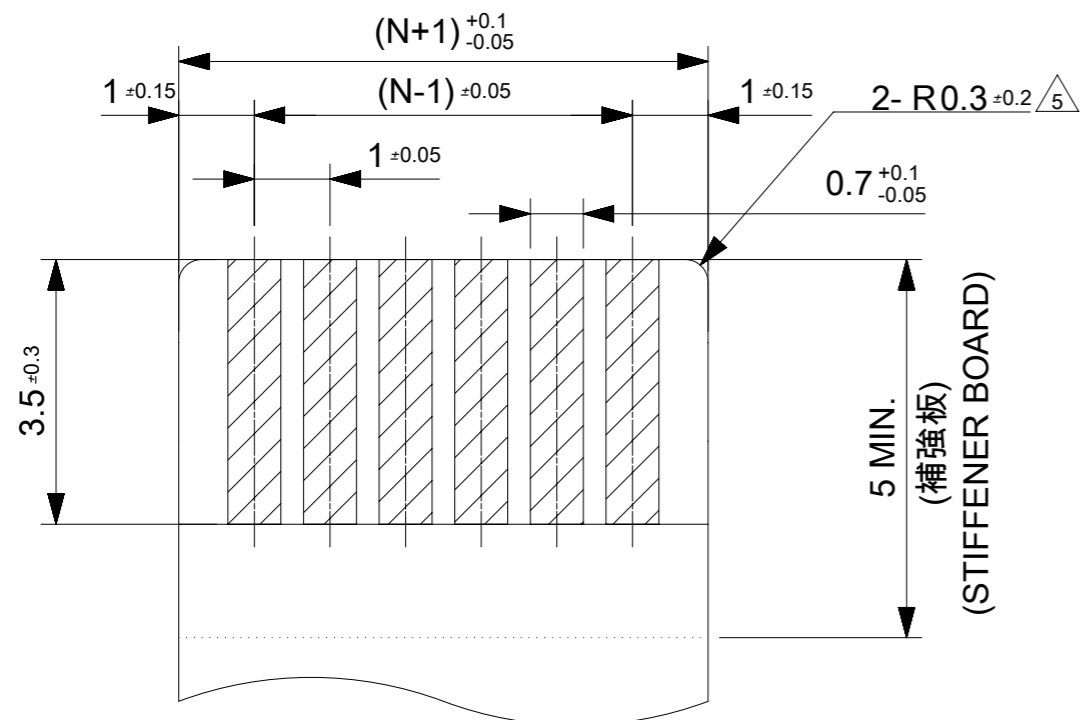

補強板: ポリイミド  
REINFORCE BOARD: POLYIMIDE

熱硬化接着剤  
THERMOSETTING ADHESIVE

ベースフィルム: ポリイミド(25μm)  
BASE FILM: POLYIMIDE(25μm)

熱硬化接着剤  
THERMOSETTING ADHESIVE

導体部: 銅箔(35μm)  
CONDUCTOR: COPPER FOIL (35μm)

熱硬化接着剤  
THERMOSETTING ADHESIVE

カバーレイ: ポリイミド(25μm)  
COVER FILM: POLYIMIDE(25μm)

補強板: ポリエステル系  
REINFORCE BOARD: PET

接着剤(難燃ポリエステル系)  
ADHESIVE (FLAME-RETARDANT  
POLYESTER ADHESIVE)

絶縁テープ: ポリエステル系(25μm)  
INSULATING FILM: PET(25μm)

接着剤(難燃ポリエステル系)  
ADHESIVE (FLAME-RETARDANT  
POLYESTER ADHESIVE)

導体部: 銅箔(35μmか50μm)  
CONDUCTOR: COPPER FOIL (35μm or 50μm)

接着剤(難燃ポリエステル系)  
ADHESIVE (FLAME-RETARDANT  
POLYESTER ADHESIVE)

絶縁テープ: ポリエステル系(25μm)  
INSULATING FILM: PET(25μm)

FPC構成推奨仕様  
STRUCTURE OF FPC

FFC構成推奨仕様  
STRUCTURE OF FFC

THIS DRAWING CONTAINS INFORMATION THAT IS PROPRIETARY TO MOLEX ELECTRONIC TECHNOLOGIES, LLC AND SHOULD NOT BE USED WITHOUT WRITTEN PERMISSION

REVISED EC NO: 103009 DRWN: MTAKAHASHI04 CHK'D: KTAKAHASHI APP: TKUSUHARA01	2016/02/09	2016/02/19	2016/02/19	GENERAL TOLERANCES (UNLESS SPECIFIED)	DIMENSION UNITS	SCALE		
	4 PLACES	± 0.05	MTAKAHASHI04		DATE	MM		##
	3 PLACES	± 0.1	CHK'D BY		DATE	DRWN BY		
	2 PLACES	± 0.2	KTAKAHASHI		2015/12/25	DATE		
1 PLACE	± 0.2	APP'R BY	DATE	YNOGAWA		2016/01/04	PRODUCT CUSTOMER DRAWING SERIES: 200529 MATERIAL NUMBER: SEE SHEET 1 CUSTOMER: GENERAL	
0 PLACES	± 0.2	DRAFT WHERE APPLICABLE MUST REMAIN WITHIN DIMENSIONS		DRAWING SIZE	THIRD ANGLE PROJECTION	DOCUMENT NUMBER: 2005291000 DOC TYPE: PSD DOC PART: 000 SHEET NUMBER: 2 OF 3		
A3								

注記 NOTES

1.使用材料 MATERIAL

ハウジング :液晶ポリマー ガラス充填、UL94V-0(ベージュ)  
 HOUSING LIQUID CRYSTAL POLYMER GLASS FILLED, UL94V-0(BEIGE)  
 アクチュエータ :ポリアミド ガラス充填、UL94V-0(黒)  
 ACTUATOR POLYAMIDE GLASS FILLED, UL94V-0(BLACK)  
 ターミナル :リン青銅(t=0.15)  
 TERMINAL PHOSPHOR BRONZE  
 金具 :リン青銅(t=0.15)  
 FITTING NAIL PHOSPHOR BRONZE

2.めっき仕様 PLATING

ターミナル TERMINAL  
 錫銀ビスマスめっき (1.0μm以上)  
 下地:ニッケルめっき (1.0μm以上)  
 TINSILVER BISMUTH PLATING (1.0 MICROMETER MINIMUM)  
 UNDERPLATE : NICKEL OVERALL (1.0 MICROMETER MINIMUM)  
 金具 FITTING NAIL  
 錫めっき(1.0μm以上)  
 下地:ニッケルめっき (1.0μm以上)  
 TIN PLATING (1.0 MICROMETER MIN.)  
 UNDER PLATING : NICKEL PLATING (1.0 MICROMETER MIN.)

3.エンボステープ梱包時は、アクチュエータが閉じた状態とする。  
 IN THE PACKAGE, ACTUATOR OF PART SHOULD BE CLOSED.

パターン剥離止め用金具

4. FITTING NAIL FOR PREVENTION OF PEELING OF P.C.B. PATTERN.

R0.3はFPC/FFC導体部にかからないこと。

5. R0.3 MUST NOT BE OVERLAPPED TO PATTERN OF FPC/FFC.

6.N:極数 N:CIRCUIT.

7.ELV及びRoHS適合品  
 ELV AND RoHS COMPLIANT

8.テールと金具を併せた平坦度は0.1以下とする。  
 TAILS AND NAILS COPLANALITY TO BE 0.1 MAX.

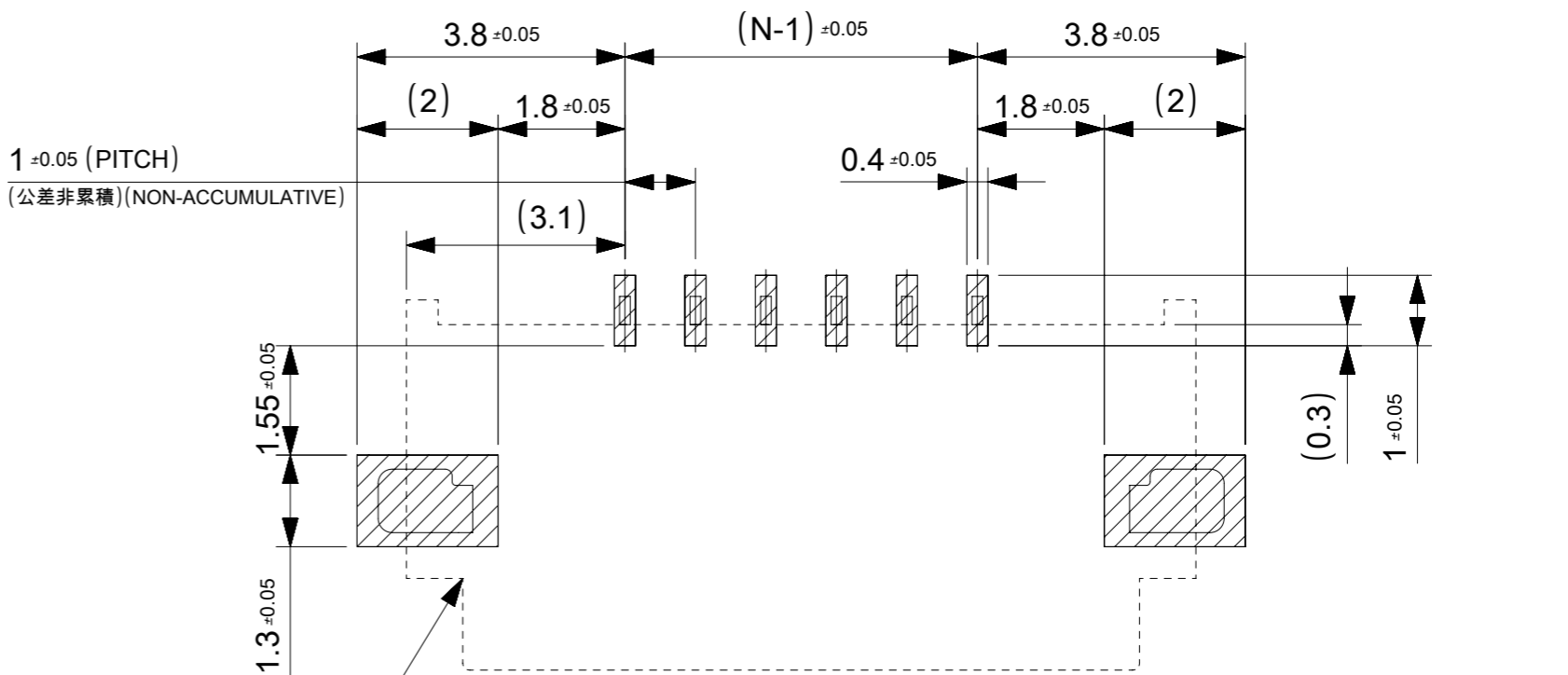

コネクタ位置  
 (CONNECTOR POSITION)

推奨基板レイアウト  
 RECOMENDED P.W.B.  
 PATTERN LAYOUT

参考マスク厚 : 100μm  
 参考マスク開口率 : 100%  
 REFERENCE SCREEN THICKNESS : 100μm  
 REFERENCE SCREEN OPEN RATIO : 100%

FPC/FFCについて ABOUT FPC/FFC

打ち抜き方向は導体側から補強板側を推奨します。  
 導体部については軟箔銅35μmまたは50μmを推奨します。  
 FFCに規定された定格温度がFFC単体前提である場合が御座います。  
 コネクタと組み合わせての実使用において、接着層が劣化するなどの信頼性を満足できないケースを回避するため、  
 実機での評価/確認をお願いいたします。

RECOMMENDED PUNCHING DIRECTION : FROM CONDUCTOR SIDE TO STIFFENER SIDE  
 RECOMMENDED CONDUCTOR SPEC : SOFT COPPER FOIL  
 RECOMMENDED CONDUCTOR THICKNESS : 35 MICROMETER OR 50 MICROMETER  
 WHEN ACTUALLY USING IT WITH CONNECTOR, PLEASE DO THE EVALUATION AND THE CONFIRMATION WITH AN ACTUAL EQUIPMENT TO EVADE THE CASE WHERE RELIABILITY CANNOT BE FILLED (THE ADHESIVE LINE OF FFC IS DETERIORATED ETC.)

FPCについて ABOUT FPC

補強フィルム材質はポリイミドを推奨します。ベースフィルムは25μmを推奨します。  
 接着剤は熱硬化接着剤を推奨します。  
 尚、接着剤の接点部への付着は導通不良の原因になりますので、染み出しが無い様お願い致します。  
 RECOMMENDED MATERIAL/THICKNESS.  
 RECOMMENDED STIFFENER MATERIAL: POLYIMIDE  
 RECOMMENDED BASE FILM THICKNESS: 25 MICROMETER  
 RECOMMENDED ADHESIVE: THERMOSETTING ADHESIVE  
 PLEASE PUT APPROPRIATE AMOUNT OF ADHESIVE ON ADHEREND BECAUSE THERE IS A POSSIBILITY THAT THE EXTRA ADHESIVE CAUSES THE DEFECT IN ELECTRICAL CONTINUITY.  
 THERE IS A POSSIBILITY THAT THE PRESCRIPT TEMPERATURE OF FFC IS SET TO SINGLE IT.

THIS DRAWING CONTAINS INFORMATION THAT IS PROPRIETARY TO MOLEX ELECTRONIC TECHNOLOGIES, LLC AND SHOULD NOT BE USED WITHOUT WRITTEN PERMISSION

REVISED	2016/02/09	GENERAL TOLERANCES (UNLESS SPECIFIED)		DIMENSION UNITS	SCALE	
	2016/02/19	ANGULAR TOL ± 1.0 °		MM	±±	
	2016/02/19	4 PLACES ± 0.05	MTAKAHASHI04	DATE	2015/12/24	
	2016/02/19	3 PLACES ± 0.1	KTAKAHASHI	DATE	2015/12/25	
EC NO: 103009 DRWN: MTAKAHASHI04 CHK'D: KTAKAHASHI REV APPR: TKUSUHARA01	2016/02/19	2 PLACES ± 0.2	YNOGAWA	DATE	2016/01/04	1.0 FPC ZIF BTM CONT HSG ASSY  PRODUCT CUSTOMER DRAWING  SERIES: 200529 MATERIAL NUMBER: SEE SHEET 1 CUSTOMER: GENERAL
	2016/02/19	1 PLACE ± 0.2	DRAWING SIZE	THIRD ANGLE PROJECTION		
	2016/02/19	0 PLACES ± 0.2	A3			
	2016/02/19	DRAFT WHERE APPLICABLE MUST REMAIN WITHIN DIMENSIONS				
RELEASE STATUS	P1	RELEASE DATE	19.02.2016	08:41:20	DOCUMENT NUMBER: 2005291000 DOC TYPE: PSD DOC PART: 000 SHEET NUMBER: 3 OF 3	

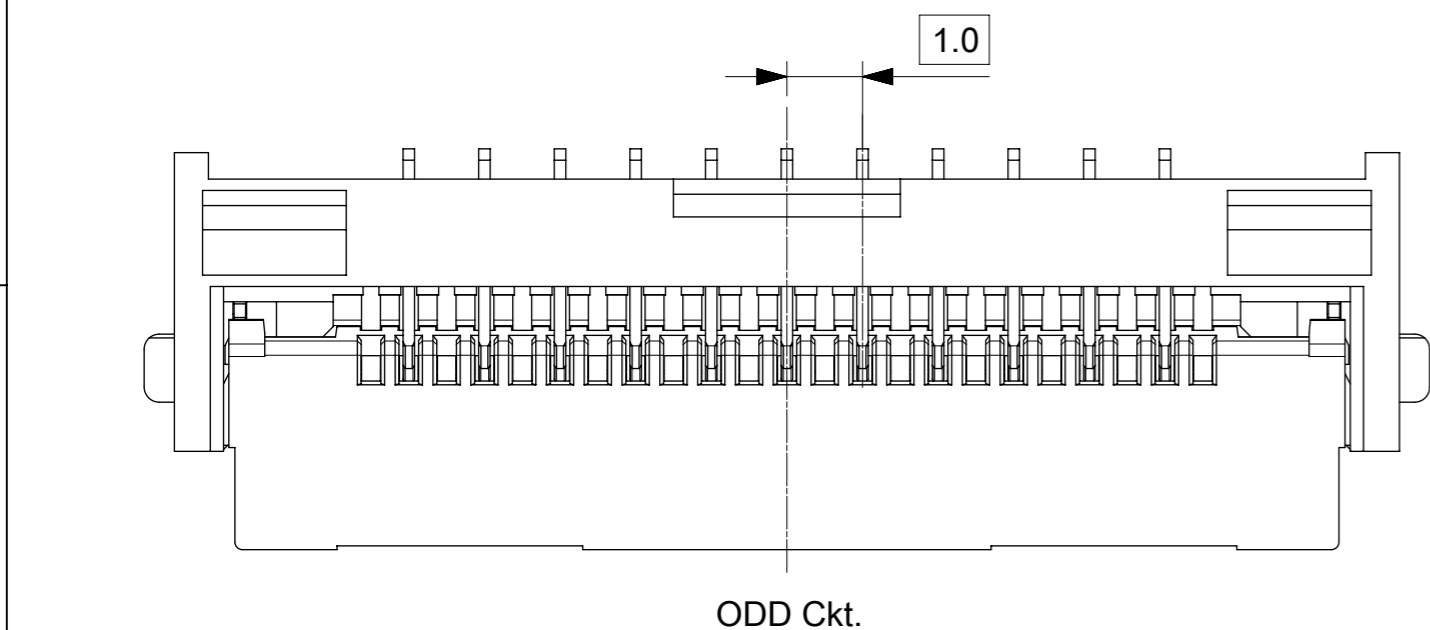
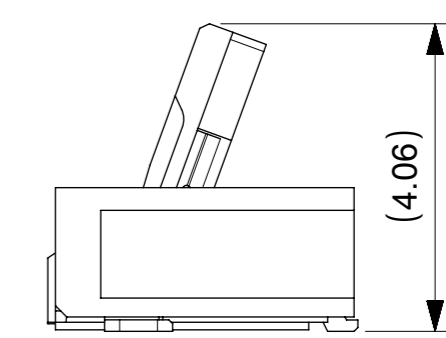
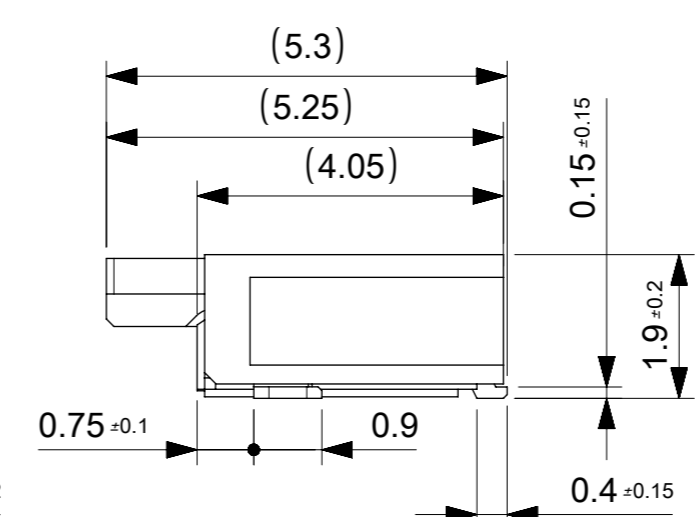
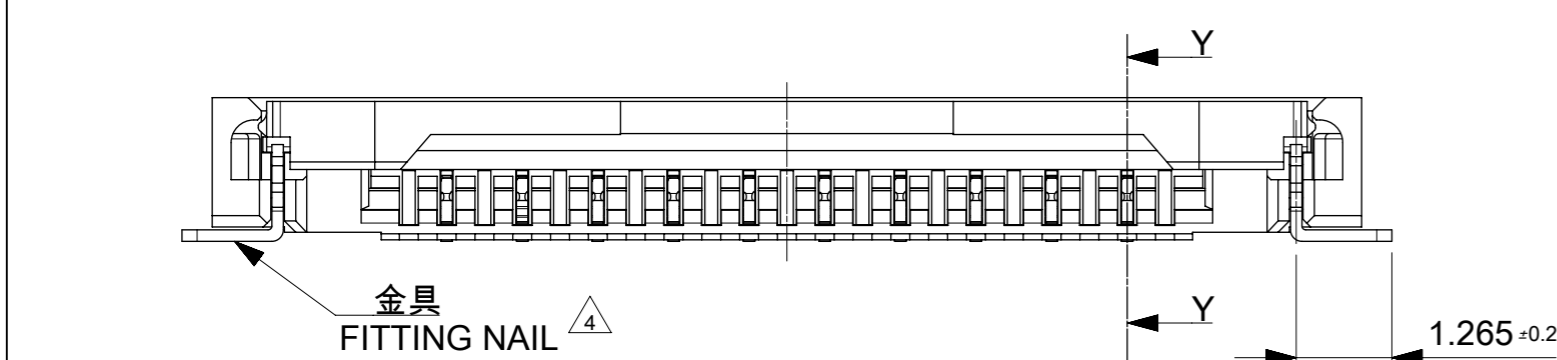
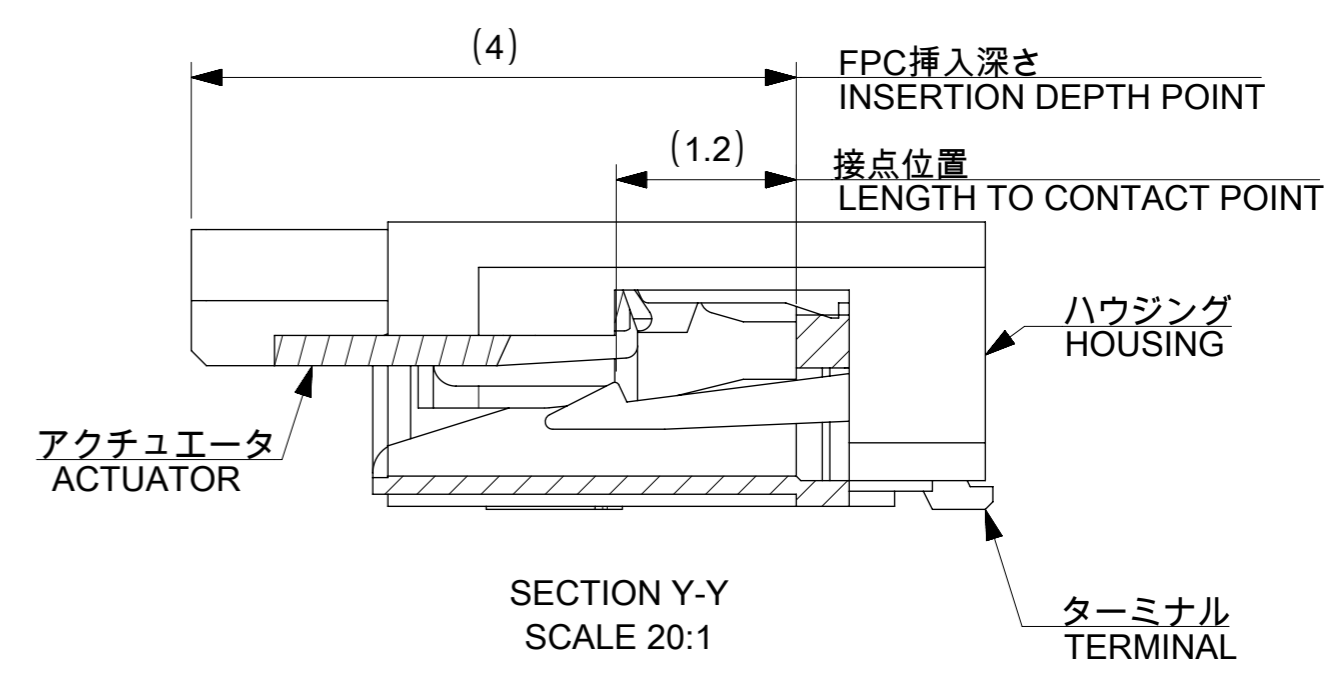
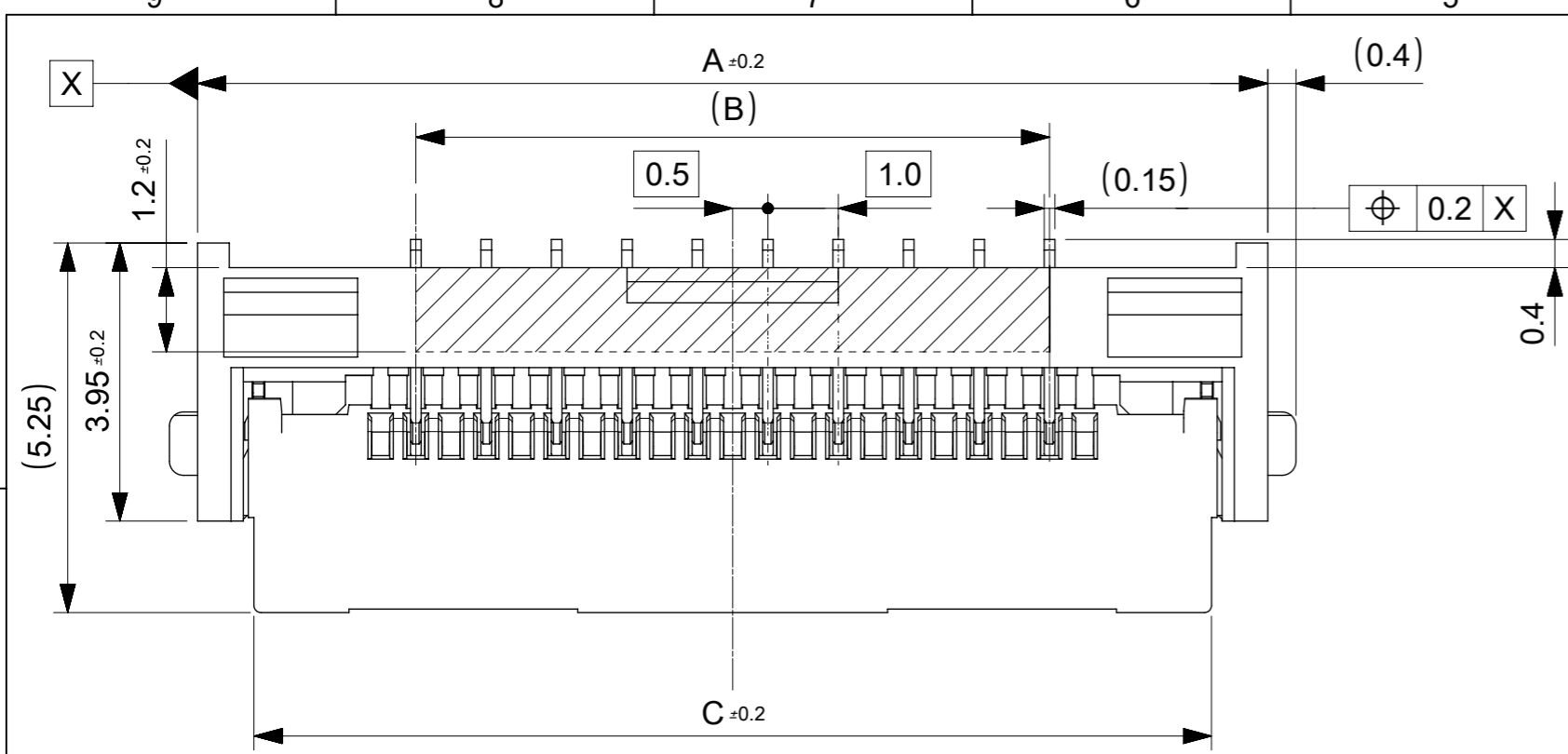

14.1	9.5	15.7	2005290220	22
11.6	7.0	13.2	2005290170	17
C	B	A	EMBOSSED PACKAGE オーダー番号 ORDER NO.	Ckt

CONNECTOR SERIES NO. 2005291\*\*0

THIS DRAWING CONTAINS INFORMATION THAT IS PROPRIETARY TO MOLEX ELECTRONIC TECHNOLOGIES, LLC AND SHOULD NOT BE USED WITHOUT WRITTEN PERMISSION

REVISED	2016/02/09	GENERAL TOLERANCES (UNLESS SPECIFIED)	DIMENSION UNITS	SCALE	<b>molex</b>	
	2016/02/19		MM	10:1		
	2016/02/19		ANGULAR TOL ± 1.0 °	DRWN BY		DATE
	4 PLACES ± 0.05		MTAKAHASHI04	2015/12/24		
EC NO: 103009	DRWN: MTAKAHASHI04	CHK'D: KTAKAHASHI	3 PLACES ± 0.1	CHK'D BY	DATE	
			2 PLACES ± 0.2	KTAKAHASHI	2015/12/25	
			1 PLACE ± 0.2	APPR BY	DATE	
			0 PLACES ± 0.2	YNOGAWA	2016/01/04	
B	REV	DRAFT WHERE APPLICABLE MUST REMAIN WITHIN DIMENSIONS	DRAWING SIZE	THIRD ANGLE PROJECTION	SERIES	
			A3		200529	
			PRODUCT CUSTOMER DRAWING		MATERIAL NUMBER	
					SEE CHART	
					CUSTOMER	
					GENERAL	
			DOCUMENT NUMBER		DOC TYPE	
			2005291006		PSD	
			DOC PART		SHEET NUMBER	
			000		1 OF 3	



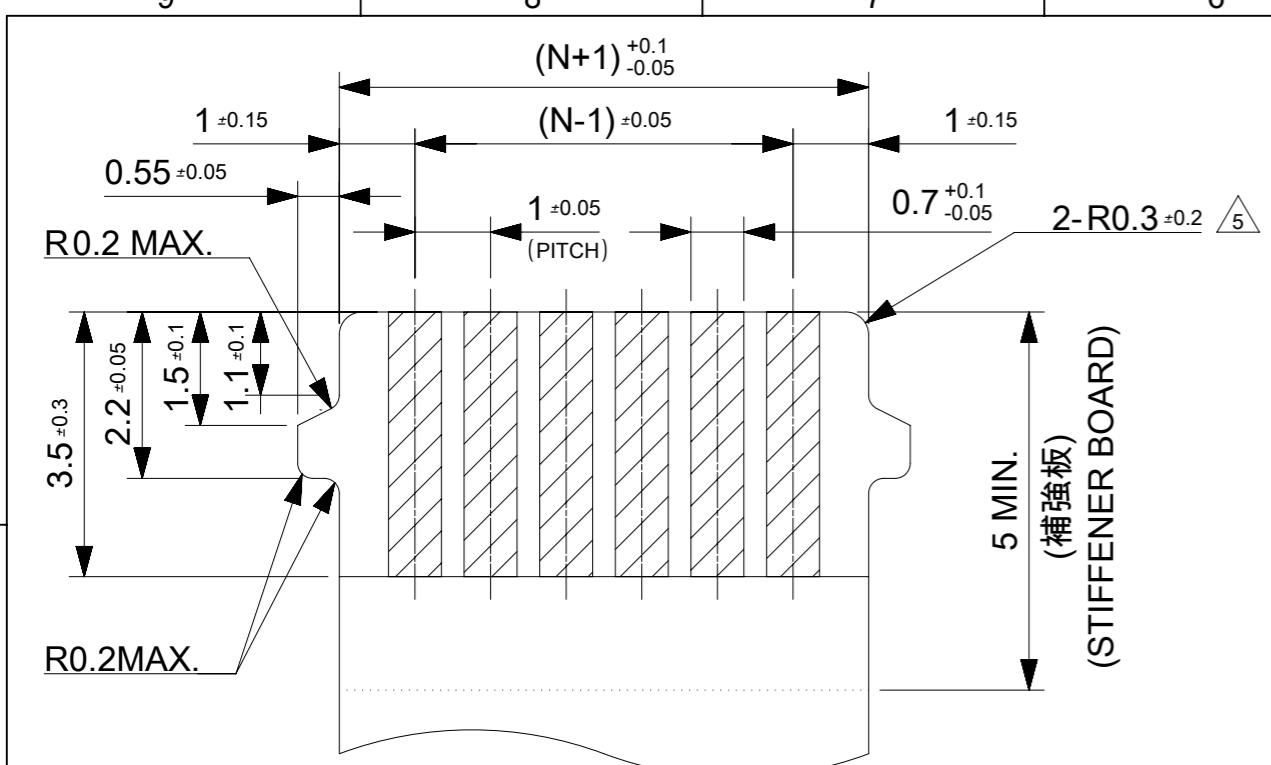

適合FPC/FFC推奨寸法  
APPLICABLE FPC/FFC  
RECOMMENDED DIMENSION

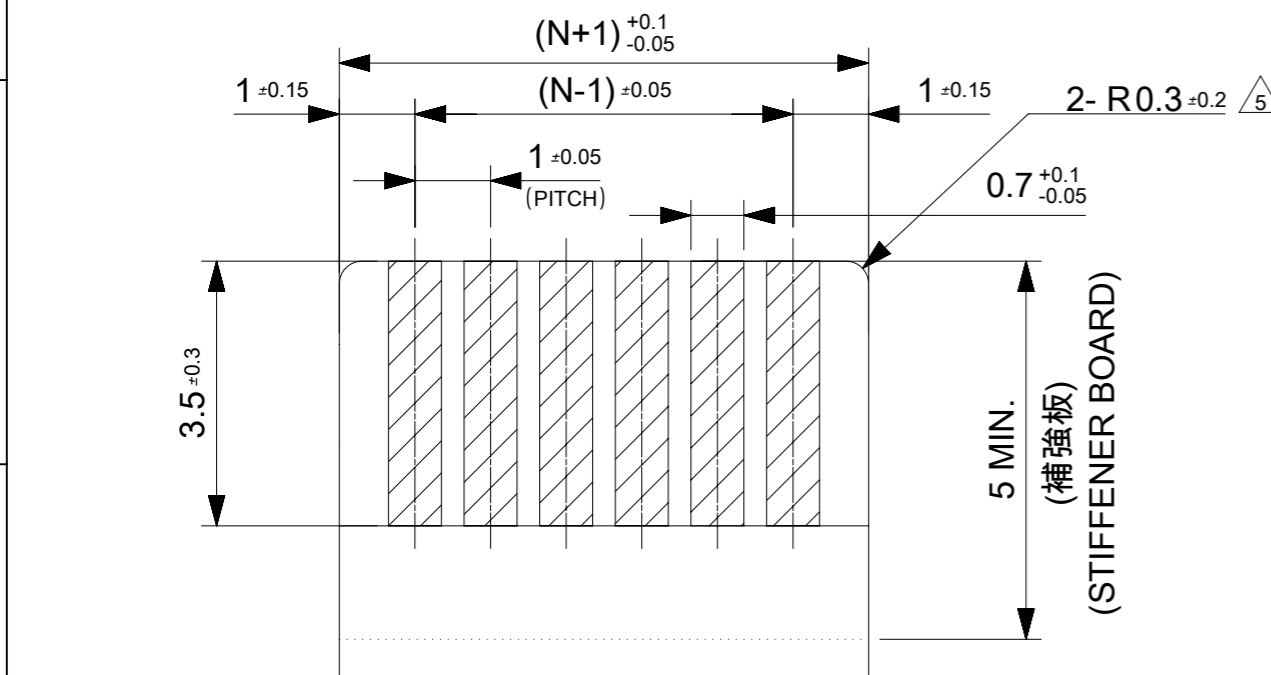

耳無し適合FPC/FFC推奨寸法  
APPLICABLE NON-TAB FPC/FFC  
RECOMMENDED DIMENSION

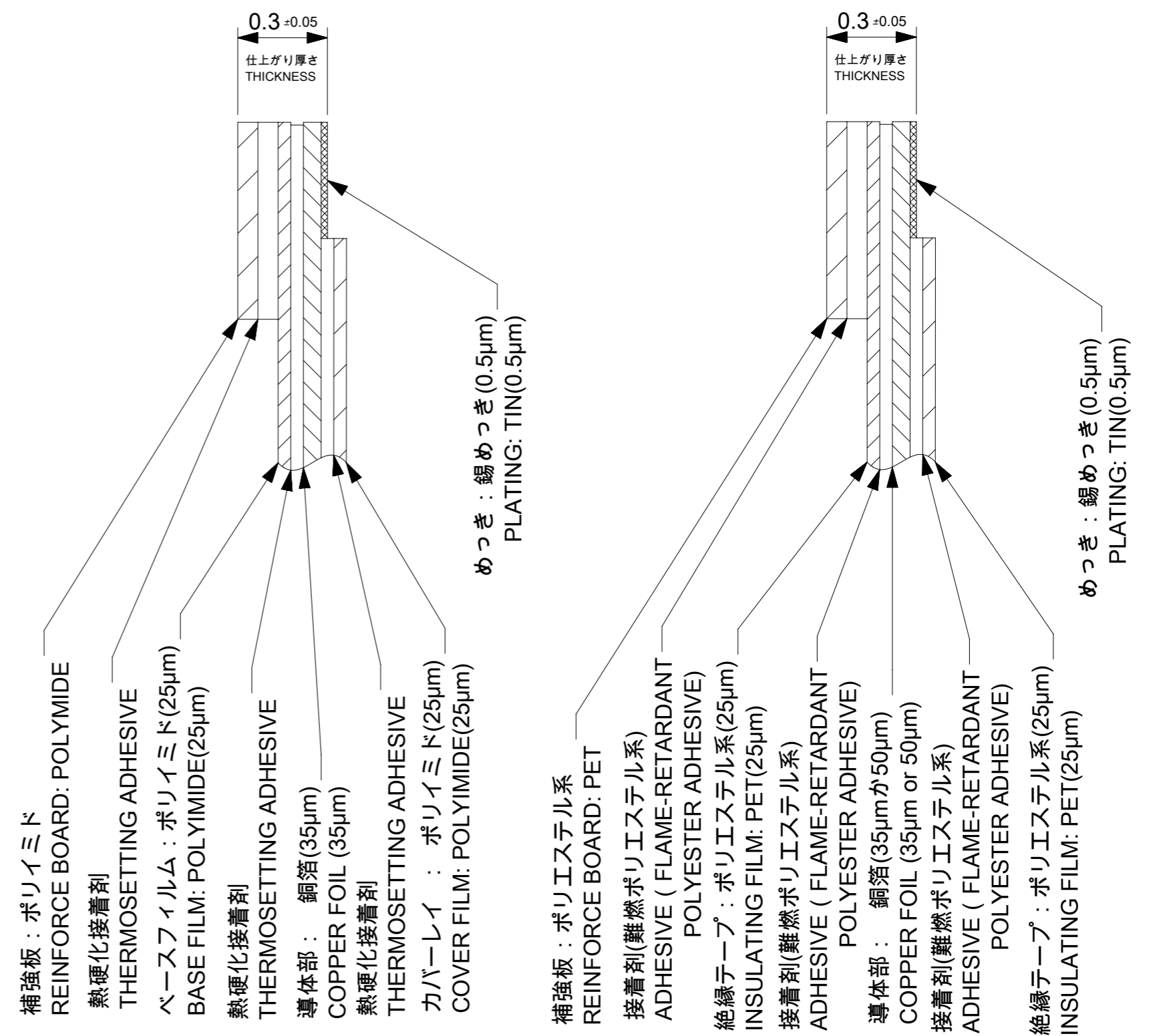

FPC構成推奨仕様  
STRUCTURE OF FPC

FFC構成推奨仕様  
STRUCTURE OF FFC

THIS DRAWING CONTAINS INFORMATION THAT IS PROPRIETARY TO MOLEX ELECTRONIC TECHNOLOGIES, LLC AND SHOULD NOT BE USED WITHOUT WRITTEN PERMISSION

EC NO: 103009 DRWN: MTAKAHASHI04 CHK'D: KTAKAHASHI APPR: TKUSUHARA01	2016/02/09	2016/02/19	2016/02/19	GENERAL TOLERANCES (UNLESS SPECIFIED) ANGULAR TOL ± 1.0 ° 4 PLACES ± 0.05 3 PLACES ± 0.1 2 PLACES ± 0.2 1 PLACE ± 0.2 0 PLACES ± 0.2 DRAFT WHERE APPLICABLE MUST REMAIN WITHIN DIMENSIONS	DIMENSION UNITS	SCALE	
	REVISED	MM	寸				
	DRWN BY	DATE	MTAKAHASHI04 2015/12/24				
	CHK'D BY	DATE	KTAKAHASHI 2015/12/25				
	APPR BY	DATE	YNOGAWA 2016/01/04				
DRAWING SIZE		THIRD ANGLE PROJECTION		A3			
PRODUCT CUSTOMER DRAWING		SERIES	MATERIAL NUMBER	CUSTOMER			
		200529	SEE SHEET 1	GENERAL		1.0 FPC ZIF BTM CONT HSG ASSY	
DOCUMENT NUMBER		DOC TYPE	DOC PART	SHEET NUMBER		2 OF 3	
2005291006		PSD	000	2 OF 3			

注記 NOTES

1.使用材料 MATERIAL

ハウジング :液晶ポリマー ガラス充填、UL94V-0(ベージュ)  
 HOUSING LIQUID CRYSTAL POLYMER GLASS FILLED, UL94V-0(BEIGE)  
 アクチュエータ :ポリアミド ガラス充填、UL94V-0(黒)  
 ACTUATOR POLYAMIDE GLASS FILLED, UL94V-0(BLACK)  
 ターミナル :リン青銅(t=0.15)  
 TERMINAL PHOSPHOR BRONZE  
 金具 :リン青銅(t=0.15)  
 FITTING NAIL PHOSPHOR BRONZE

2.めっき仕様 PLATING

ターミナル TERMINAL  
 錫銀ビスマスめっき (1.0μm以上)  
 下地:ニッケルめっき (1.0μm以上)  
 TINSILVER BISMUTH PLATING (1.0 MICROMETER MINIMUM)  
 UNDERPLATE : NICKEL OVERALL (1.0 MICROMETER MINIMUM)  
 金具 FITTING NAIL  
 錫めっき(1.0μm以上)  
 下地:ニッケルめっき (1.0μm以上)  
 TIN PLATING (1.0 MICROMETER MIN.)  
 UNDER PLATING : NICKEL PLATING (1.0 MICROMETER MIN.)

3.エンボステーブ梱包時は、アクチュエータが閉じた状態とする。  
 IN THE PACKAGE, ACTUATOR OF PART SHOULD BE CLOSED.

4. パターン剥離止め用金具  
 FITTING NAIL FOR PREVENTION OF PEELING OF P.C.B. PATTERN.

5. R0.3はFPC/FFC導体部にかからないこと。  
 R0.3 MUST NOT BE OVERLAPPED TO PATTERN OF FPC/FFC.

6.N:極数 N:CIRCUIT.

7.ELV及びRoHS適合品  
 ELV AND RoHS COMPLIANT

8.テールと金具を併せた平坦度は0.1以下とする。  
 TAILS AND NAILS COPLANALITY TO BE 0.1 MAX.

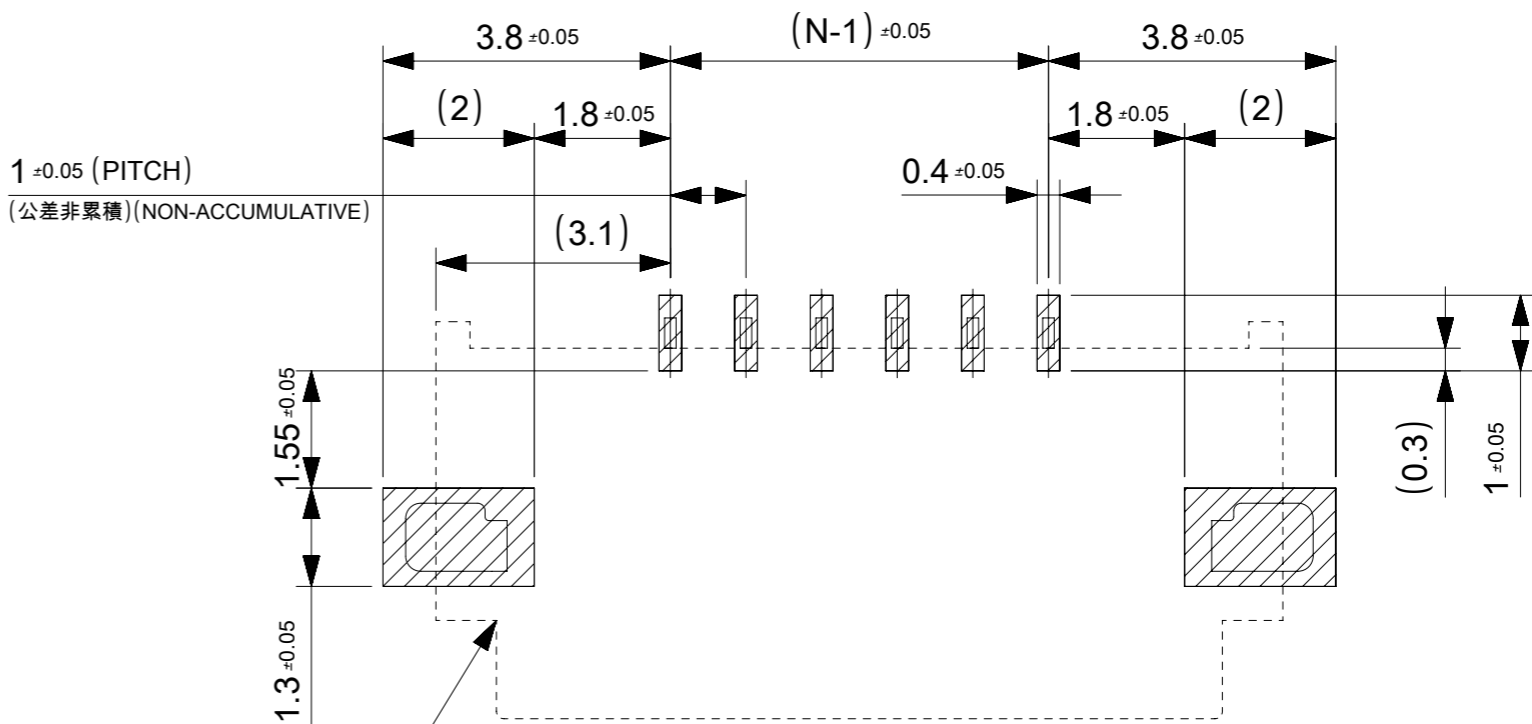

コネクタ位置  
 (CONNECTOR POSITION)

推奨基板レイアウト  
 RECOMENDED P.W.B.  
 PATTERN LAYOUT

参考マスク厚 : 100μm  
 参考マスク開口率 : 100%  
 REFERENCE SCREEN THICKNESS : 100μm  
 REFERENCE SCREEN OPEN RATIO : 100%

FPC/FFCについて ABOUT FPC/FFC

打ち抜き方向は導体側から補強板側を推奨します。  
 導体部については軟箔銅35μmまたは50μmを推奨します。  
 FFCに規定された定格温度がFFC単体前提である場合が御座います。  
 コネクタと組み合わせての実使用において、接着層が劣化するなどの信頼性を満足できないケースを回避するため、  
 実機での評価/確認をお願いいたします。

RECOMMENDED PUNCHING DIRECTION : FROM CONDUCTOR SIDE TO STIFFENER SIDE  
 RECOMMENDED CONDUCTOR SPEC : SOFT COPPER FOIL  
 RECOMMENDED CONDUCTOR THICKNESS : 35 MICROMETER OR 50 MICROMETER  
 WHEN ACTUALLY USING IT WITH CONNECTOR, PLEASE DO THE EVALUATION AND THE CONFIRMATION WITH AN ACTUAL EQUIPMENT TO EVADE THE CASE WHERE RELIABILITY CANNOT BE FILLED (THE ADHESIVE LINE OF FFC IS DETERIORATED ETC.)

FPCについて ABOUT FPC

補強フィルム材質はポリイミドを推奨します。ベースフィルムは25μmを推奨します。  
 接着剤は熱硬化接着剤を推奨します。  
 尚、接着剤の接点部への付着は導通不良の原因になりますので、染み出しが無い様お願い致します。  
 RECOMMENDED MATERIAL/THICKNESS.  
 RECOMMENDED STIFFENER MATERIAL: POLYIMIDE  
 RECOMMENDED BASE FILM THICKNESS: 25 MICROMETER  
 RECOMMENDED ADHESIVE: THERMOSETTING ADHESIVE  
 PLEASE PUT APPROPRIATE AMOUNT OF ADHESIVE ON ADHEREND BECAUSE THERE IS A POSSIBILITY THAT THE EXTRA ADHESIVE CAUSES THE DEFECT IN ELECTRICAL CONTINUITY.  
 THERE IS A POSSIBILITY THAT THE PRESCRIPT TEMPERATURE OF FFC IS SET TO SINGLE IT.

THIS DRAWING CONTAINS INFORMATION THAT IS PROPRIETARY TO MOLEX ELECTRONIC TECHNOLOGIES, LLC AND SHOULD NOT BE USED WITHOUT WRITTEN PERMISSION

REVISED	2016/02/09	2016/02/19	2016/02/19	GENERAL TOLERANCES (UNLESS SPECIFIED)	DIMENSION UNITS	SCALE				
	EC NO: 103009	DRWN: MTAKAHASHI04	CHK'D: KTAKAHASHI		APPR: TKUSUHARA01	MM		±±		
	4 PLACES	± 0.05	MTAKAHASHI04		DATE	2015/12/24		1.0 FPC ZIF BTM CONT HSG ASSY		
	3 PLACES	± 0.1	KTAKAHASHI		DATE	2015/12/25				
	2 PLACES	± 0.2	YNOGAWA		DATE	2016/01/04				
1 PLACE	± 0.2	PRODUCT CUSTOMER DRAWING								
0 PLACES	± 0.2	DRAWING SIZE	THIRD ANGLE PROJECTION	SERIES	MATERIAL NUMBER	CUSTOMER				
DRAFT WHERE APPLICABLE MUST REMAIN WITHIN DIMENSIONS					A3		200529	SEE SHEET 1	GENERAL	
							DOCUMENT NUMBER	DOC TYPE	DOC PART	SHEET NUMBER
							2005291006	PSD	000	3 OF 3