

REMARK:

1. CHARACTERISTICS:

RATED VOLTAGE: 250V
 RATED CURRENT: 2.5AMP
 CONTACT RESISTANCE: 25mohms MAX(40mohms MAX FOR AFTER TEST).
 INSULATION RESISTANCE: 5000Mohms MIN.at 500V DC
 DIELECTRIC STRENGTH: 750VRMS
 OPERATING TEMPERATURE RANGE: -55° C~105° C
 INSERTION/EXTRACTION FORCE PER CONTACT: 5N Max./0.2N Min.
 MATING/UNMATING CYCLES: 200MATINGS MIN FOR GOLD-FLASH
 500MATINGS MIN FOR 30u" GOLD.

2. MATERIAL:

INSULATORS: THERMOPLASTIC G.F(UL94V-0) BLACK
 CONTACTS: COPPER ALLOY, GOLD(G/F or 30u")TOP OVER CONTACT AREA,
 100u" Min MATTE TIN TOP OVER SOLDER AREA,
 50u" Min NICKEL UNDER PLATE.
 SHELL: CARBON STEEL,100u" Min NICKEL TOP OVER,
 50u" Min COPPER UNDER PLATE.
 Z BRACKET: COPPER ALLOY, 100u" Min MATTE TIN PLATED.
 SCREW LOCK: COPPER ALLOY , 50u" Min NICKEL PLATED.

3. PART NUMBER DESCRIPTION:

10090926-P XX X X LF

SERIES NO. _____
 TYPE _____
 P: PIN (MALE)
 NUMBER OF CONTACTS _____
 15: 15-PIN
 26: 26-PIN
 44: 44-PIN
 LF: ROHS COMPLIANT
 FLANGE MOUNTING OPTION
 X: UNC #4-40 CLINCHNUTS
 CONTACT FINISH
 4: GOLD FLASH
 6: 30u" GOLD

POS.	PART NO.	THREAD TYPE
15P	10090926-P15*XLF	UNC #4-40
26P	10090926-P26*XLF	UNC #4-40
44P	10090926-P44*XLF	UNC #4-40

POS.	A	B	C	D	H
15P	30.81	24.99	16.92	2.29	5.90 ^{+0.25} ₀
26P	39.24	33.32	25.25	2.29	5.90 ^{+0.25} ₀
44P	53.04	47.04	38.96	2.29	5.70 ^{+0.25} ₀

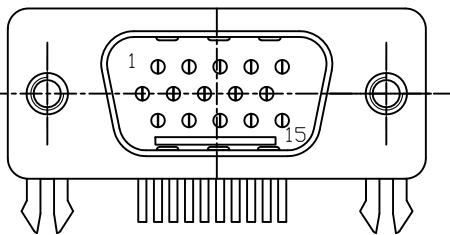
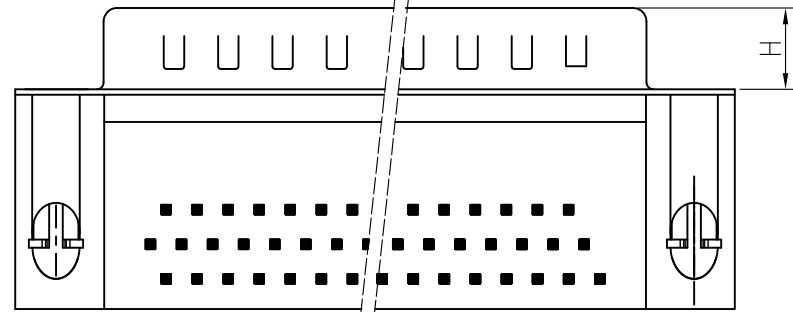
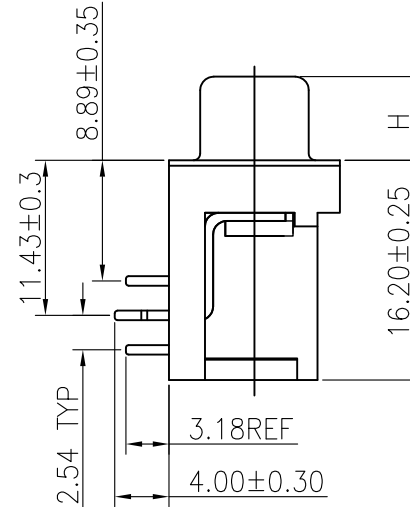

FOR 15P

mat'l. code		surface		tolerance		projection		product family		
-		ISO 1302		ISO 406 ISO 1101		MM		D-SUB		
ltr		ecn no	dr	date	tolerances unless otherwise specified					
E	ELX-I-19529	MP		2014/11/22	angles	linear	title			
F	ELX-I-20972	AB		2015/05/30			H/D D-SUB MALE RIGHT ANGLE			
G	ELX-I-21468	MP		2015/07/21	0°±2'		scale 1:1			
		dr	MITHUN PAUL 2014/11/22				dwg no			
		enrg	MITHUN PAUL 2014/11/22				sheet 1 of 3 size			
		chr	ALIAS BABU 2014/11/22				10090926 A4			
		appd	BIJU K PAUL 2014/11/22				type Product Customer Drawing			
sheet	revision	G	G	G						
index	sheet	1	2	3						

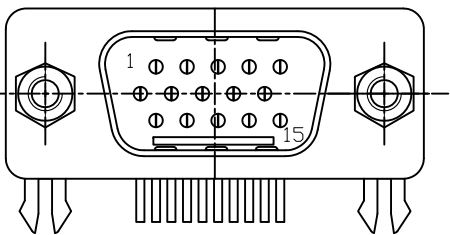
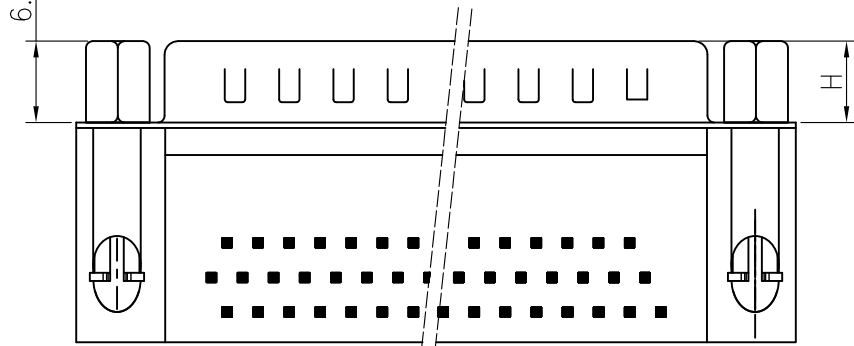
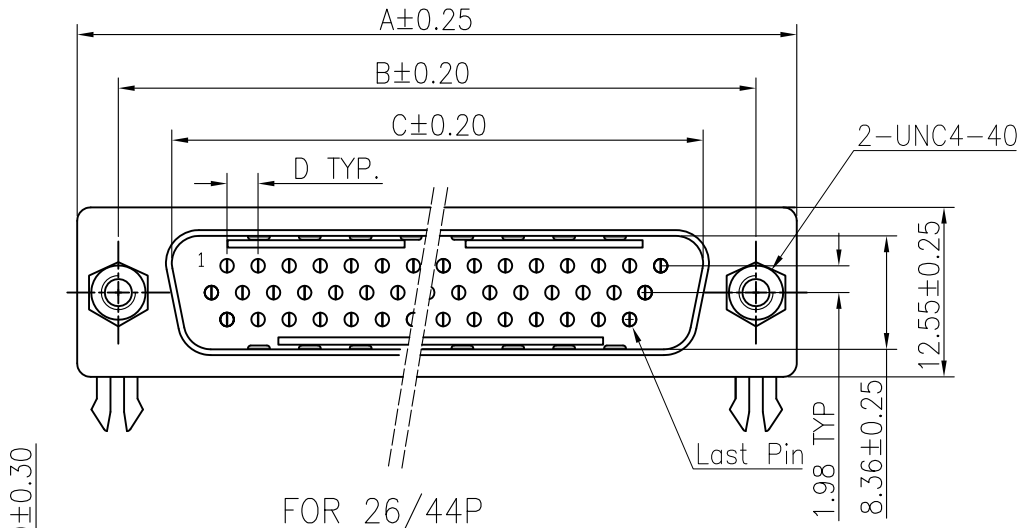

REMARK:

1. CHARACTERISTICS:

RATED VOLTAGE: 250V
 RATED CURRENT: 2.5AMP
 CONTACT RESISTANCE: 25mohms MAX(40mohms MAX FOR AFTER TEST).
 INSULATION RESISTANCE: 5000Mohms MIN. at 500V DC
 DIELECTRIC STRENGTH: 750VRMS
 OPERATING TEMPERATURE RANGE: -55° C~105° C
 INSERTION/EXTRACTION FORCE PER CONTACT: 5N Max./0.2N Min.
 MATING/UNMATING CYCLES: 200MATINGS MIN FOR GOLD-FLASH
 500MATINGS MIN FOR 30u" GOLD.

2. MATERIAL:

INSULATORS: THERMOPLASTIC G.F(UL94V-0) BLACK
 CONTACTS: COPPER ALLOY (G/F or 30u") TOP OVER CONTACT AREA,
 100u" Min MATTE TIN TOP OVER SOLDER AREA,
 50u" Min NICKEL UNDER PLATE.
 SHELL: CARBON STEEL, 100u" Min NICKEL TOP OVER,
 50u" Min COPPER UNDER PLATE.
 Z BRACKET: COPPER ALLOY, 100u" Min MATTE TIN PLATED.
 SCREW LOCK: COPPER ALLOY, 50u" Min NICKEL PLATED.
 NUT: COPPER ALLOY, 50u" Min NICKEL PLATED.

3. PART NUMBER DESCRIPTION:

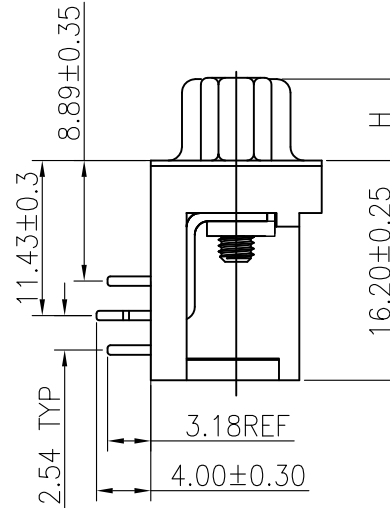
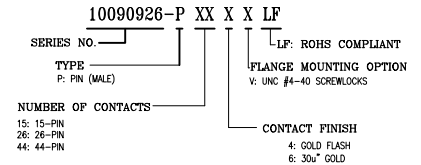

POS.	PART NO.	A	B	C	D	H
15P	10090926-P15*VLF	30.81	24.99	16.92	2.29	5.90 ^{+0.25} ₀
26P	10090926-P26*VLF	39.24	33.32	25.25	2.29	5.90 ^{+0.25} ₀
44P	10090926-P44*VLF	53.04	47.04	38.96	2.29	5.90 ^{+0.25} ₀

mat'l. code	-	surface	ISO 1302 ✓	tolerance	ISO 406 ISO 1101	projection	product family	D-SUB
ltr	ecn no	dr	date	tolerances unless otherwise specified		MM	title	
g				angles	Linear	MM	H/D D-SUB MALE RIGHT ANGLE	
				0°±2'	0.00±0.10	scale 1:1	dwg no	
		dr	MITHUN PAUL	2014/11/22		FCI	sheet 2 of 3 size	
		enr	MITHUN PAUL	2014/11/22			10090926	
		chr	ALIAS BABU	2014/11/22			A4	
		appd	BIJU K PAUL	2014/11/22			type Product Customer Drawing	
sheet index	revision sheet							

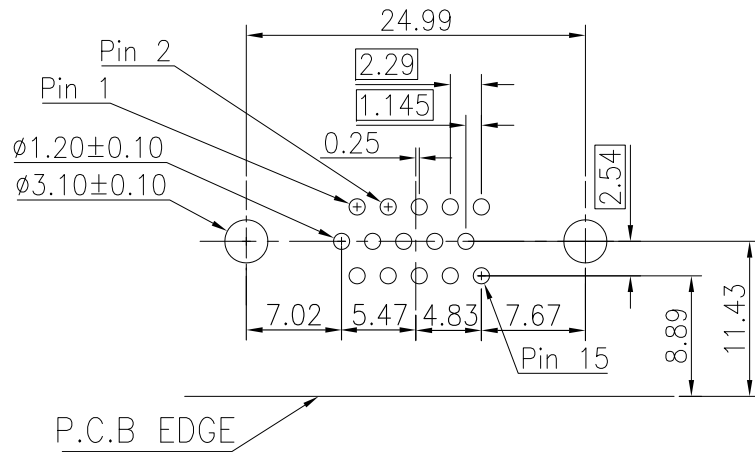

P.C.B LAYOUT (FOR 15P)

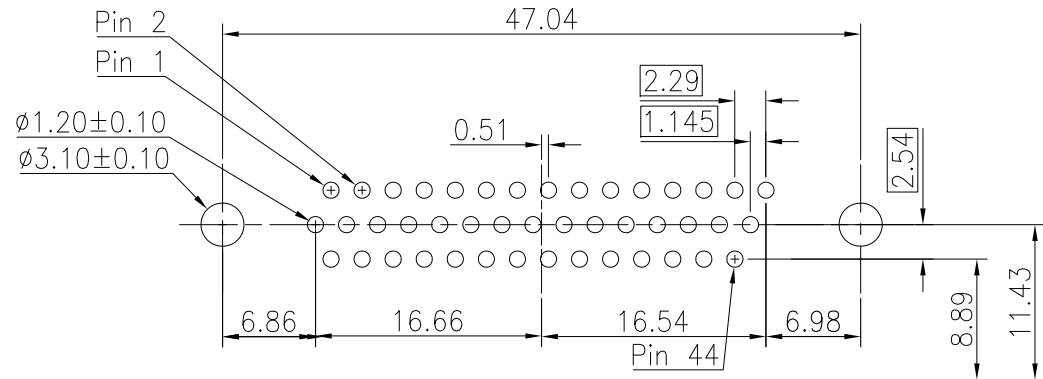

P.C.B LAYOUT (FOR 44P)

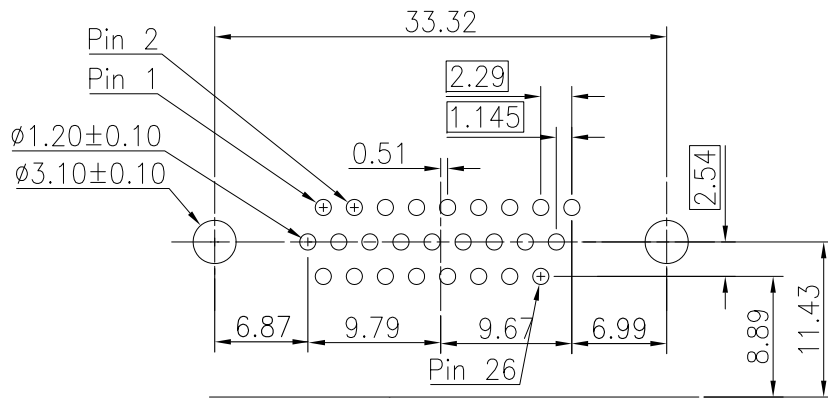

P.C.B LAYOUT (FOR 26P)

mat'l. code		surface		tolerance		projection		product family		
-		ISO 1302 <input checked="" type="checkbox"/>		ISO 406 ISO 1101				D-SUB		
ltr	ecn no	dr	date	tolerances unless otherwise specified						
g				angles	linear	MM		title		
				$0^\circ \pm 2'$		scale 1:1		H/D D-SUB MALE RIGHT ANGLE		
				dr	MITHUN PAUL	2014/11/22			dwg no	
				enr	MITHUN PAUL	2014/11/22			sheet 3 of 3	
				chr	ALIAS BABU	2014/11/22			size	
				appd	BIJU K PAUL	2014/11/22			A4	
sheet index	revision sheet	type Product Customer Drawing								