

PRODUCT NUMBER

77315-YXX-XXLF

- RoHS COMPATIBLE
SEE NOTE 7
- TOTAL NB OF POSITIONS 01 TO 36
- PACKAGING, NOTE 3
- PIN STYLE SEE SHEET 2
- PLATING SEE SHEET 2

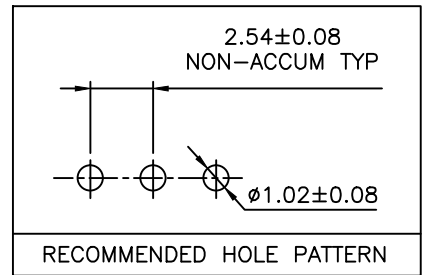
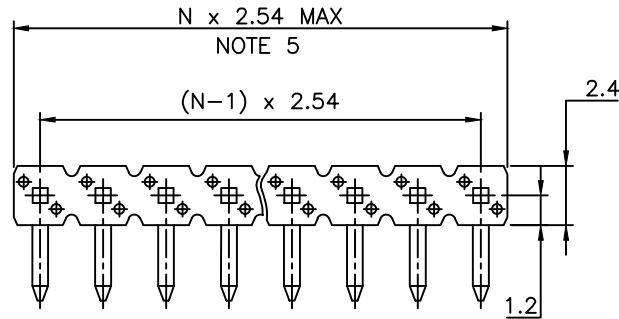

NOTES:

1. HOUSING MAT'L : HIGH TEMPERATURE THERMOPLASTIC. UL94V-0 COLOR: BLACK
2. PIN MATERIAL : PHOSPHOR BRONZE
3. PACKAGING:
 - PACKAGING POLYBAG
 - "V" BLIBOX PACK FOR CUSTOMER DEDICATED PART
4. 9N MIN RETENTION IN EITHER DIRECTION
5. TO DETERMINE DIMENSIONS :
N = NUMBER OF POSITIONS PER ROW
EXAMPLE : 8 POS N x 2.54 = 20.32mm
6. UNDERPLATING : 1.27µm Ni MIN
7. RoHS COMPATIBLE PRODUCT SPECIFICATIONS
 - a - PLATING:
 - "LF" MEANS THE PRODUCT IS LEAD-FREE, 2µm MINIMUM MATTE TIN OVER 1.27µm MINIMUM NICKEL UNDERPLATE.
 - b - MANUFACTURING PROCESS COMPATIBILITY
 - THE HOUSING WILL WITHSTAND EXPOSURE TO 260°C ±5°C SOLDER BATH TEMPERATURE FOR 5 SECONDS IN A WAVE SOLDER APPLICATION WITH A 1.6mm MIN THICK CIRCUIT BOARD.
 - c - LABELING:
 - MEETS PACKAGING SPECS AS PER GS-14-920
 - d - LEGAL STATEMENT: SEE GS-47-0004

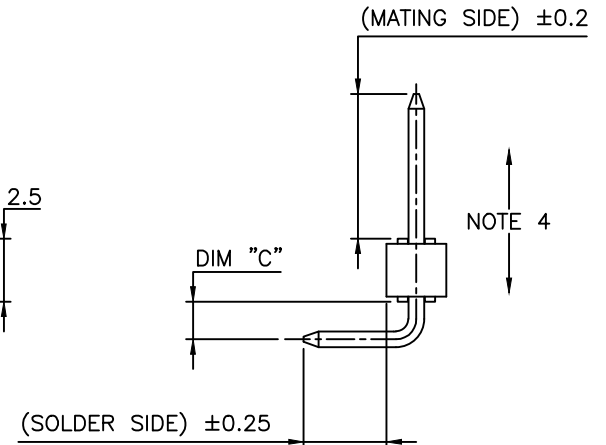
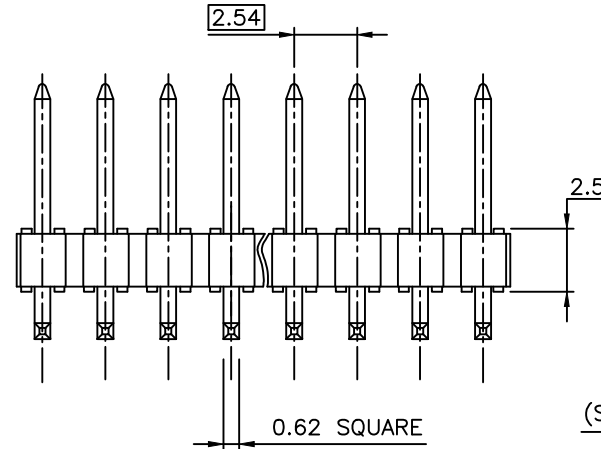

mat'l. code		surface		tolerance		projection		product family	
SEE NOTES		ISO 1302 ✓		ISO 406 ISO 1101		mm		BERGSTIK	
ltr	ecn no	dr	date	tolerances unless otherwise specified		mm		title	
AK	B-15093	JCO	13.06.28	angles	Linear	mm		UNSHR.HEADER	
AL	B-15388	LMU	13.07.31			scale 5:1		RA SR TMT	
AM	B16178	JCO	13.10.31					dwg no	
AN	B-17109	JCO	14.03.06	dr	D.LE	01.01.24	sheet 1 of 2		size
AP	B-17839	JCO	14.06.03	enr	JM.C	01.01.24	77315		A3
AR	B-18916	LMU	14.09.26	chr	JM.C	01.01.24	type		Drawing
AS	B-19715	BVE	14.12.11	appd	JF.N	01.01.24	CUSTOMER		
sheet	revision	AS	AM						
index	sheet	1	2						

1 | 2 | 3 | 4 | 5 | 6

PLATING

- 1 = 0.76µm GOLD/GXT ON CONTACT AREA, 2µm TIN MIN ON TAIL
- 4 = 2µm TIN MIN FULL PLATED
- 5 = 0.25µm GOLD/GXT ON CONTACT AREA, 2µm TIN MIN ON TAIL
- 8 = 0.38µm GOLD/GXT ON CONTACT AREA, 2µm TIN MIN ON TAIL
- G = 0.76µm FULL GXT
- S = 0.38µm FULL GXT
- 1.27µm NICKEL MIN UNDERLAYER FOR ALL PLATING VERSIONS

PRODUCT SPECIFICATIONS			
PIN STYLE	MATING	SOLDER	DIM "C"
01	5.72	2.57	1.5
02	5.72	5.11	1.5
07	5.72	5.11	3.9
13	5.72	3.45	1.5
18	5.84	3.05	1.5
22	11.71	3.2	1.5
24	6.75	2.85	1.5
25	8.07	3.05	1.5
26	8.2	12.6	1.5
27	5	3.9	1.5
28	3.1	3.1	1.5
29	9.7	2.90	1.5
30	8.30	4.40	1.5
31	11.70	2.80	1.5
32	8.90	3.05	1.5
33	10.20	3.05	1.5
34	10.00	3.25	1.5
35	5.72	12.73	1.5
36	N/A		
37	N/A		
38	8.51	5.51	1.5
39	9.80	9.30	1.5
40	8.13	2.54	3.90
41	14.20	3.05	1.5
42	9.00	7.20	1.5
43	8.08	2.79	1.5
44	15.70	2.79	1.5

A | B | C | D



Copyright FCI

mat'l. code		surface		tolerance		projection		product family	
SEE NOTES		ISO 1302 ✓		ISO 406 ISO 1101				BERGSTIK	
ltr	ecn no	dr	date	tolerances unless otherwise specified				title	
AG	F12-0095	LMU	12.10.25	angles	linear	mm		UNSHR.HEADER	
AH	B-15093	JCO	13.06.28			scale 5:1		RA SR TMT	
AJ	B-15388	LMU	13.07.31					dwg no	
AK	B-16178	JCO	13.10.31	dr	D.LE	01.01.24		sheet 2 of 2 size	
AL	B-17109	JCO	14.03.06	enr	JM.C	01.01.24		77315 A3	
AM	B-18916	LMU	14.09.26	chr	JM.C	01.01.24		type CUSTOMER Drawing	
				appd	JF.N	01.01.24			
sheet index	revision sheet								

form: A3 | 1 | 2 | 3 | 4 | 5 | 6