

TABLE 1						MATED HEIGHT WITH QSS-01
STYLE	"A"	"B"	BODY	GROUND PLANE	TERMINAL	
-01	.1680[4.267]	.1600[4.064]	QTS-25-01-D-XX	T-1G1-01-XXX	T-1S56-01-XXX	.197[5.00] REF
-02	.2861[7.267]	.2781[7.064]	QTS-25-02-D-XX	T-1G1-02-XXX	T-1S56-22-XXX	.315[8.00] REF

TABLE 6		
No. OF POS	"D"	"E"
-025	.788 [20.00]	.728 [18.48]
-050	1.575 [40.01]	1.515 [38.48]
-075	2.363 [60.01]	2.303 [58.48]
** -100	3.150 [80.01]	3.090 [78.49]
** -125	3.938 [100.01]	3.878 [98.49]

TABLE 2	
COPLANARITY (INCLUDES GND PLANE)	
No OF POSITIONS	
-025 THRU -075	.004[.10]
** -100 THRU ** -125	.006[.15]

** = SEE NOTE 17

** = SEE NOTE 17

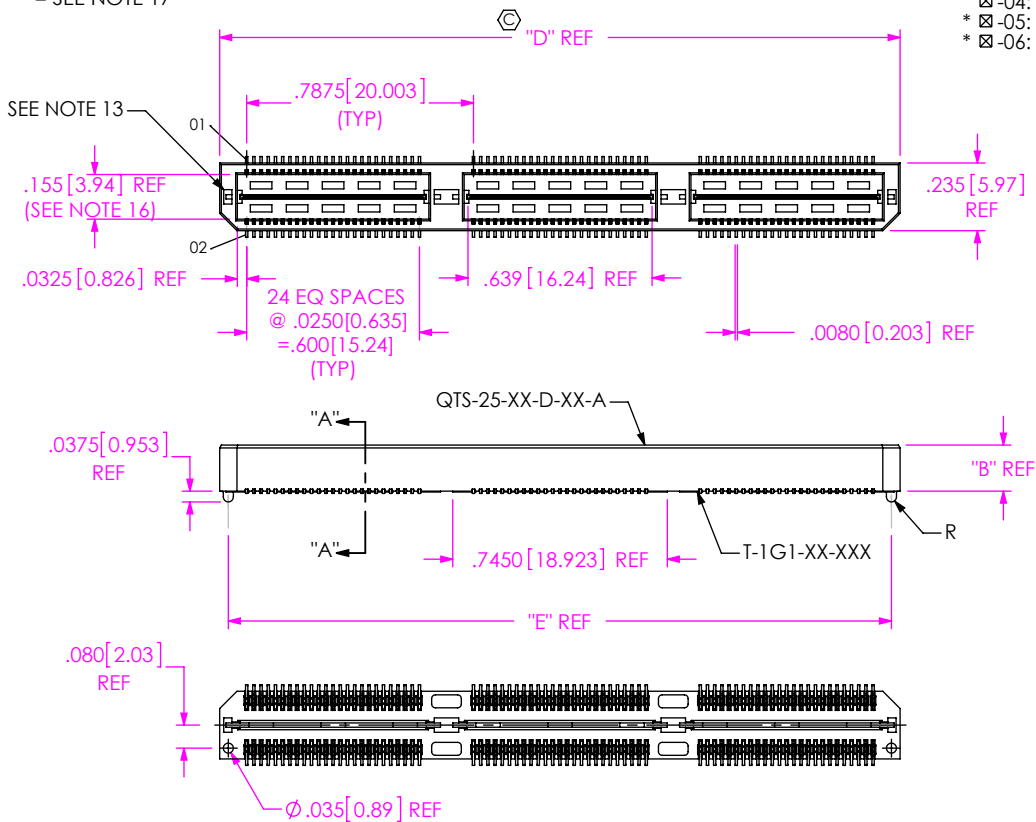

FIG 1
-A: ALIGNMENT PIN OPTION (QTS-075-01-XXX-D-A SHOWN)

NOTES:

- ⊕ REPRESENTS A CRITICAL DIMENSION.
- DELETED.
- DELETED.
- MINIMUM TERMINAL RETENTION: 6 OZ.
- MINIMUM GROUND PLANE RETENTION: 1 LB.
- DELETED.
- PARTS TO BE MOLDED TO POSITION.
- MAXIMUM VARIANCE OF .002[0.05].
- DIMENSION APPLIES TO TERMINALS AND GROUND PLANES INDEPENDENT OF THE GROUND PLANE OR TERMINAL RESPECTIVELY.
- LEAD STYLES -03 AND -05: TOP BODY (QTS) CANNOT HAVE -A OPTION AND -04 AND -06 CAN USE EITHER -A OR -LC BODY.
- T-1SXX-XX-L CAN BE SUBSTITUTED FOR T-1SXX-XX-F.
- GROUND PLANE PRESS HEIGHT MUST BE .003[.08] LESS THAN THE MAX HEIGHT OR .001[0.03] GREATER THAN THE MINIMUM HEIGHT OF THE TERMINALS.
- WINDOW NOT PRESENT ON LEAD STYLES -02 THRU -06 HEIGHT PER REV. E OF THE QTS-25-XX-D-XX-X-XX.
- NOTE DELETED.
- DUE TO THE HIGH AMOUNT OF INSERTION FORCE NEEDED, THE -LC OPTION IS NOT COMPATIBLE WITH AUTO PLACEMENT. SAMTEC RECOMMENDS MANUAL PLACEMENT FOR ALL ASSEMBLIES WITH THE -LC OPTION.
- PIN CAN EXTEND PAST WALL .003[0.08] MAX.
- AVAILABLE FOR EXISTING CUSTOMERS ONLY.

QTS-XXX-XX-XXX-D-XXX

No OF POSITIONS

- 025, -050, -075, ** -100, ** -125 (PER ROW)
- ** (SEE NOTE 17)

LEAD STYLE

- 01: .1680[4.267]
- 02: .2861[7.264]
- ⊗ -03: .4043[10.269]
- ⊗ -04: .6001[15.246]
- * ⊗ -05: .7181[18.240]
- * ⊗ -06: .8361[21.237]

OPTION

- LC: LOCKING CLIPS (SEE NOTE 10 AND NOTE 15) (USE LC-08-TM-01)
- A: ALIGNMENT PINS (SEE NOTE 10) (USE QTS-25-XX-D-XX-A)
- K: POLYIMIDE FILM PAD (USE K-DOT-.276-.375-.005, SEE FIG 3, SHT 2)
- GP: GUIDE POST, (SEE FIG 4, SHT 2) (AVAILABLE ON STYLE -01 ONLY)
- TR: TAPE & REEL (75 POS MAX) (N/A ON STYLE -05 & -06)

ROW SPECIFICATION

- D: DOUBLE (USE QTS-25-XX-D-XX & QTSH-25-XX-D-XX)

No OF BANKS

PLATING SPECIFICATION

- F: 3μ" FLASH SELECTIVE GOLD IN CONTACT AREA, MATTE TIN ON TAIL (USE T-1SXX-XX-F & T-1G1-XX-F) (SEE NOTE 11)
- L: 10μ" LIGHT SELECTIVE GOLD IN CONTACT AREA, MATTE TIN ON TAIL (USE T-1SXX-XX-L & T-1G1-XX-L)
- H: 30μ" HEAVY GOLD IN CONTACT AREA, 3μ" GOLD ON TAIL (USE T-1SXX-XX-H & T-1G1-XX-G)
- C: 50μ" HEAVY GOLD IN CONTACT AREA, MATTE TIN ON TAIL (USE T-1SXX-XX-C & T-1G1-XX-L)
- STL: 30μ" HEAVY SELECTIVE GOLD IN CONTACT AREA, TIN LEAD ON TAIL (USE T-1SXX-XX-STL & T-1G1-XX-STL)
- FTL: 3μ" FLASH SELECTIVE GOLD IN CONTACT AREA, TIN LEAD ON TAIL (USE T-1SXX-XX-FTL & T-1G1-XX-FTL)

- ⊗ = SEE SHEET 3
- * = NOT TOOLED

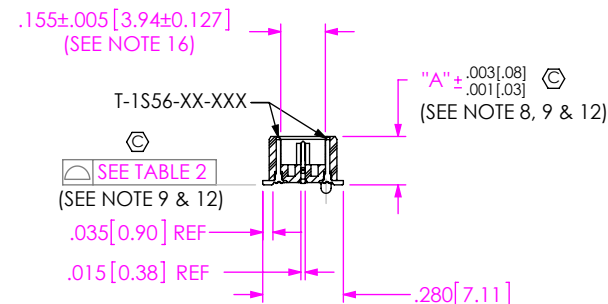

SECTION "A"-"A"

UNLESS OTHERWISE SPECIFIED, DIMENSIONS ARE IN INCHES. TOLERANCES ARE:
DECIMALS: .XX: ±.01[.3] .XXX: ±.005[.13] .XXXX: ±.0020[.051]
ANGLES: ± 2°

PROPRIETARY NOTE
THIS DOCUMENT CONTAINS CONFIDENTIAL AND PROPRIETARY INFORMATION AND ALL DESIGN, MANUFACTURING, REPRODUCTION, USE, PATENT RIGHTS AND SALES RIGHTS ARE EXPRESSLY RESERVED BY SAMTEC, INC. THIS DOCUMENT SHALL NOT BE DISCLOSED, IN WHOLE OR PART, TO ANY UNAUTHORIZED PERSON OR ENTITY NOR REPRODUCED, TRANSFERRED OR INCORPORATED IN ANY OTHER PROJECT IN ANY MANNER WITHOUT THE EXPRESS WRITTEN CONSENT OF SAMTEC, INC.



520 PARK EAST BLVD, NEW ALBANY, IN 47150
PHONE: 812-944-6733 FAX: 812-948-5047
e-Mail: info@SAMTEC.com code: 55322

MATERIAL: DO NOT SCALE DRAWING SHEET SCALE: 1:5:1
INSULATOR: LCP, UL94V-0; COLOR: BLACK
TERMINAL: PHOS BRONZE
GROUND PLANE: PHOS BRONZE

DESCRIPTION: H.635mm DOUBLE ROW HS TERMINAL ASSEMBLY

DWG. NO. QTS-XXX-XX-XXX-D-XXX

BY: DEAN P 09-14-2010 SHEET 1 OF 3

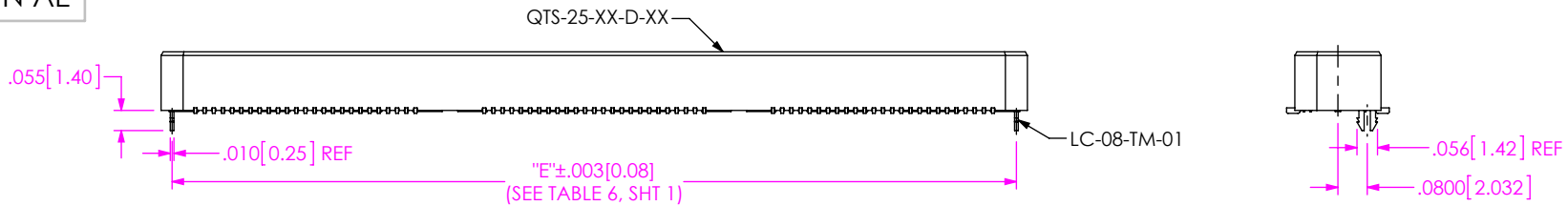

FIG 2
 -LC: LOCKING CLIP OPTION
 (QTS-075-01-XXX-D-LC SHOWN)
 (DIFFERENT AS SHOWN, OTHERWISE SAME AS FIG 1)

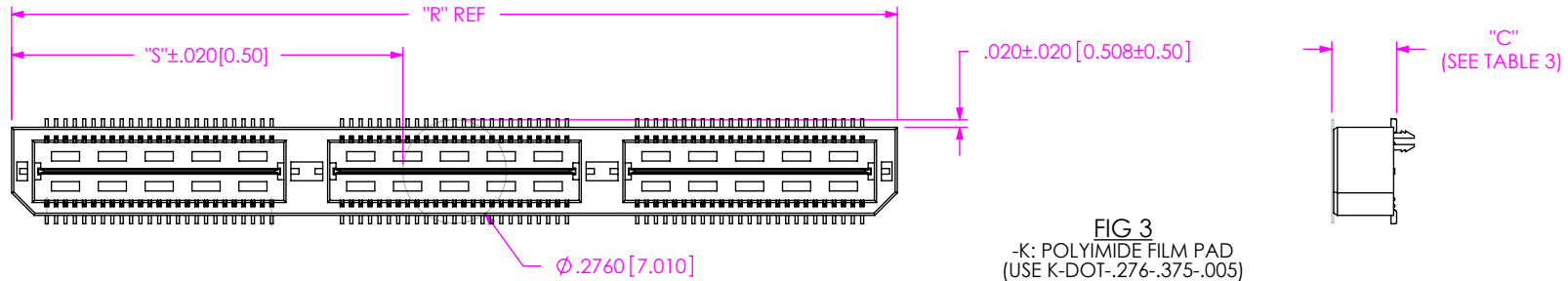

FIG 3
 -K: POLYIMIDE FILM PAD
 (USE K-DOT-.276-.375-.005)

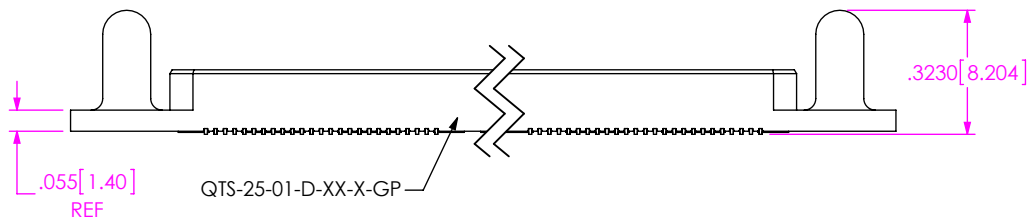
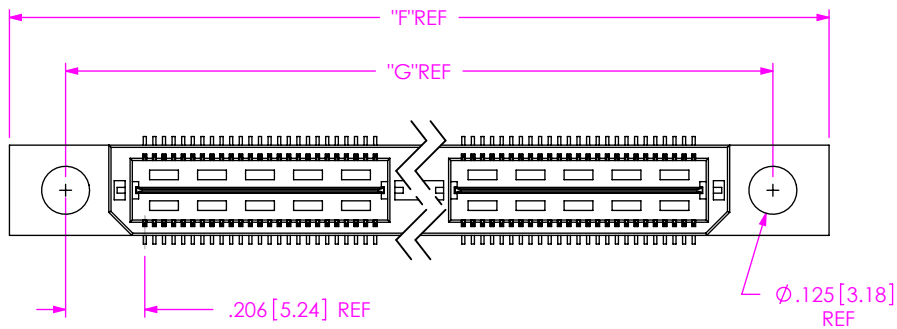

FIG 4
 -GP: GUIDE POST OPTION
 (QTS-075-01-XXX-D-GP SHOWN)
 (DIFFERENT AS SHOWN, OTHERWISE SAME AS FIG 1)
 (AVAILABLE ON STYLE -01 ONLY)

TABLE 7

No OF POS	"R"		"S"	
	-LC, -A	-GP	-LC, -A	-GP
-025	.788 [20.00]	1.305 [33.15]	.256 [6.50]	.515 [13.07]
-050	1.575 [40.01]	2.093 [53.15]	.650 [16.50]	.908 [23.07]
-075	2.363 [60.01]	2.880 [73.15]	1.043 [26.50]	1.302 [33.07]
** -100	3.150 [80.01]	3.668 [93.15]	1.437 [36.50]	1.696 [43.07]
** -125	3.938 [100.01]	4.455 [113.16]	1.831 [46.50]	2.090 [53.07]

** = SEE NOTE 17

TABLE 8

POS	"F"	"G"
-025	1.305 [33.15]	1.013 [25.72]
-050	2.093 [53.15]	1.800 [45.72]
-075	2.880 [73.15]	2.588 [65.72]
** -100	3.668 [93.15]	3.375 [85.73]
** -125	4.455 [113.16]	4.163 [105.73]

** = SEE NOTE 17

TABLE 3

STYLE	"C"
-01	.173 [4.39]
-02	.291 [7.39]
-03	.409 [10.39]
-04	.605 [15.37]
-05	.723 [18.36]
-06	.841 [21.36]

PROPRIETARY NOTE
 THIS DOCUMENT CONTAINS INFORMATION
 CONFIDENTIAL AND PROPRIETARY TO
 SAMTEC, INC. AND SHALL NOT BE REPRODUCED
 OR TRANSFERRED TO OTHER DOCUMENTS OR
 DISCLOSED TO OTHERS OR USED FOR ANY
 PURPOSE OTHER THAN THAT WHICH IT WAS
 OBTAINED WITHOUT THE EXPRESSED WRITTEN
 CONSENT OF SAMTEC, INC.

DO NOT SCALE DRAWING

SHEET SCALE: 2:1

samtec

520 PARK EAST BLVD, NEW ALBANY, IN 47150
 PHONE: 812-944-6733 FAX: 812-948-5047
 e-Mail: info@SAMTEC.com code: 53322

DESCRIPTION:
 H.635mm DOUBLE ROW HS TERMINAL ASSEMBLY

DWG. NO. **QTS-XXX-XX-XXX-D-XXX**

BY: DEAN P 09-14-2010 SHEET 2 OF 3

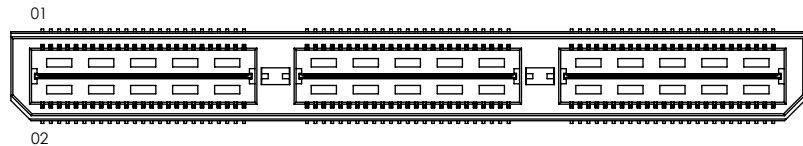
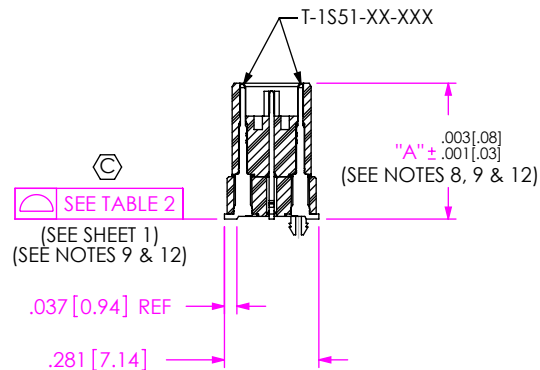
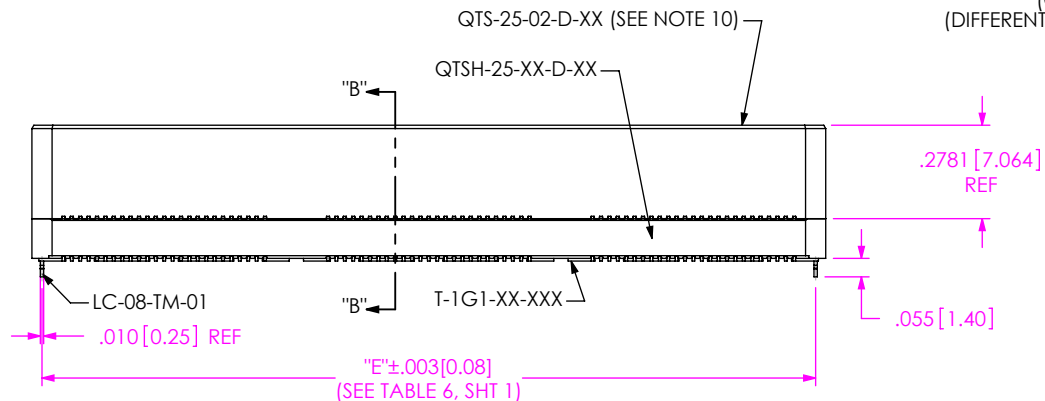

TABLE 4					
STYLE	"A"	GROUND PLANE	TERMINAL	BOTTOM SPACER BODY	MATED HEIGHT WITH QSS-01
-03	.4043 [10.269]	T-1G1-03-XXX	T-1S51-03-XXX	QTSH-25-01-D-XX-X	.433 [11.00] REF
-04	.6001 [15.246]	T-1G1-04-XXX	T-1S51-04-XXX	QTSH-25-01-D-XX-X	.630 [16.00] REF
* -05	.7181 [18.240]	T-1G1-05-XXX	T-1S51-05-XXX	QTSH-25-02-D-XX-X	.748 [19.00] REF
* -06	.8361 [21.237]	T-1G1-06-XXX	T-1S51-06-XXX	QTSH-25-02-D-XX-X	.866 [22.00] REF

(* = NOT TOOLED)

FIG 5
(QTS-075-03-XXX-D-LC SHOWN)
(DIFFERENT AS SHOWN, OTHERWISE SAME AS FIG 1)



SECTION "B"-"B"

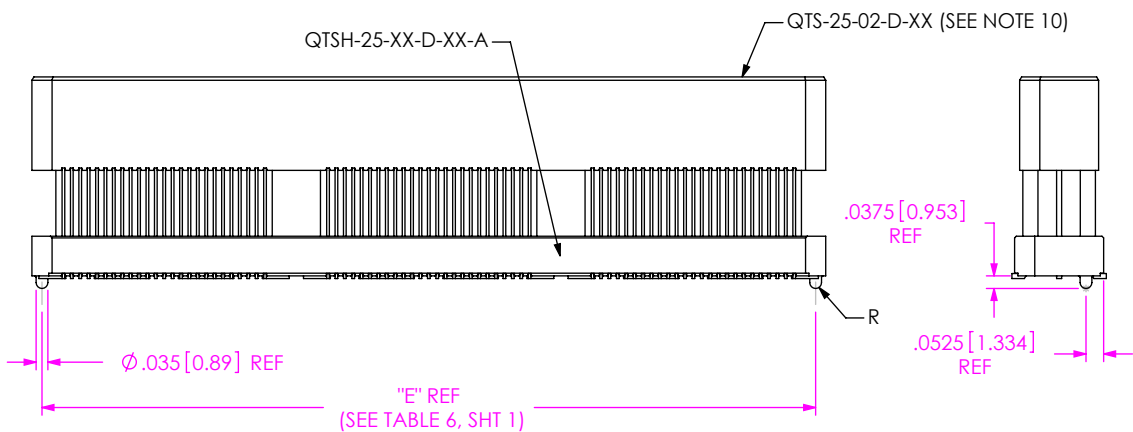
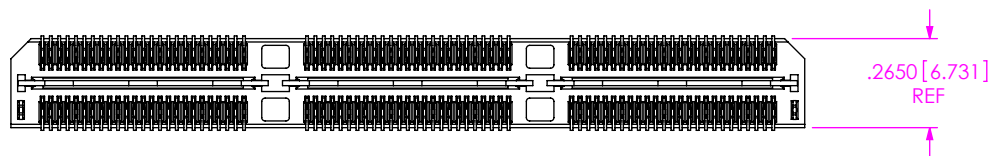

FIG 6
(QTS-075-04-XXX-D-A SHOWN)
(DIFFERENT AS SHOWN, OTHERWISE SAME AS FIG 1)
(STYLE -03, -04, -05 & -06)

F:\DWG\MISC\MKTG\QTS-XXX-XX-XXX-D-XXX-MKT.SLDDRW

PROPRIETARY NOTE
THIS DOCUMENT CONTAINS INFORMATION
CONFIDENTIAL AND PROPRIETARY TO
SAMTEC, INC. AND SHALL NOT BE REPRODUCED
OR TRANSFERRED TO OTHER DOCUMENTS OR
DISCLOSED TO OTHERS OR USED FOR ANY
PURPOSE OTHER THAN THAT WHICH IT WAS
OBTAINED WITHOUT THE EXPRESSED WRITTEN
CONSENT OF SAMTEC, INC.

DO NOT SCALE DRAWING

SHEET SCALE: 1:75:1



520 PARK EAST BLVD, NEW ALBANY, IN 47150
PHONE: 812-944-6733 FAX: 812-948-5047
e-Mail: info@SAMTEC.com code: 55322

DESCRIPTION:
H.635mm DOUBLE ROW HS TERMINAL ASSEMBLY
DWG. NO. QTS-XXX-XX-XXX-D-XXX

BY: DEAN P 09-14-2010 SHEET 3 OF 3