

SECTION A-A

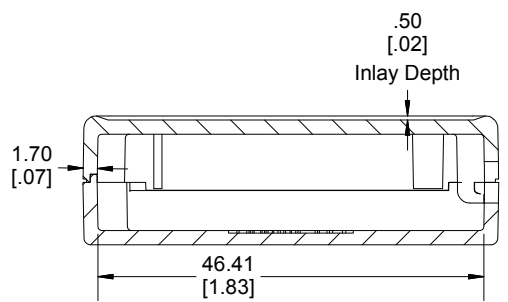

SECTION B-B

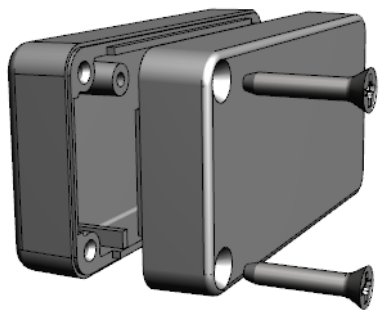
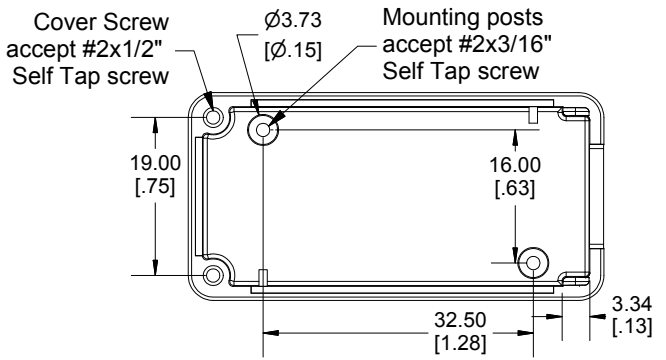
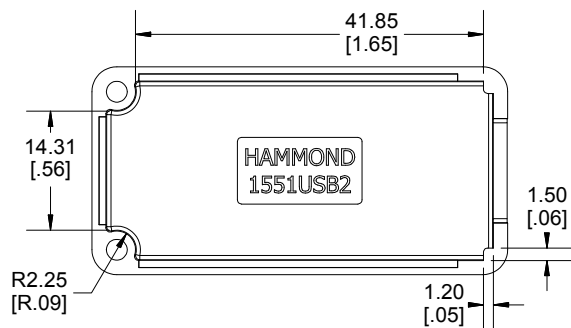
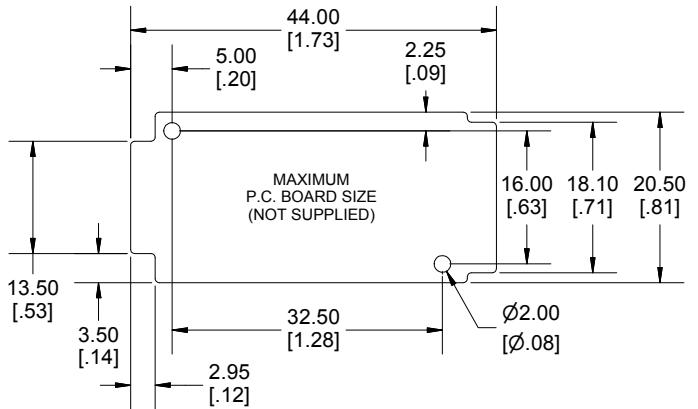

Enclosures can be Factory Modified (Milling, Drilling, Printing etc.)
 Contact Factory mjm@hammondmfg.com for quotes
 Solid models of this enclosure available in STEP or IGES.
 (Part number and text placement/orientation on our products are subject to change,
 we do not recommend using them as a locating reference for modification purposes)

NOTE	
Purchased assembly includes box, lid, 2 cover screws.	
Enclosure molded from general purpose ABS Plastic.	
Other materials / colours available consult factory.	
Recommended Torque : (35-43) Ozf.in / (25-30) cN.m	

PART NUMBERS		
1551USB2 Enclosure		
Black Enclosure - Ral 9011 - UL94 - HB		1551USB2BK
Gray Enclosure - RAL 7035 - UL94 - HB		1551USB2GY
Translucent Blue - UL94 - HB		1551USB2TBU
Translucent Clear - UL94 - HB		1551USB2CLR
Translucent Smoke - UL94 - HB		1551USB2TSK
Translucent Red - UL94 - HB		1551USB2TRD
ACCESSORIES		
P.C. Board Plastite Self Tapping Screw		1553WTS100 (Pkg 100)
Black Cover Screws #2 X 1/2" Self-tapping		1551USB50BK (Pkg 50)
P.C. Board Screws		1551ATS50 (Pkg 50)
#2 x 3/16" self-tapping (4.8mm)		1551ATS100 (Pkg 100)

HAMMOND MANUFACTURING

1551USB2

www.hammondmfg.com

Dimensions:
 mm
 [inches]