

**SECTION A-A**

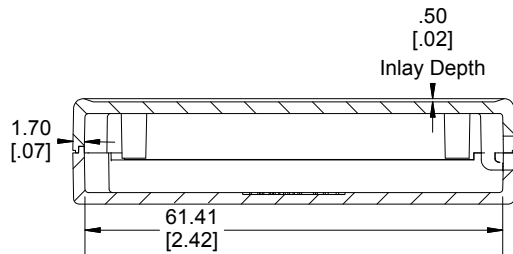

**SECTION B-B**

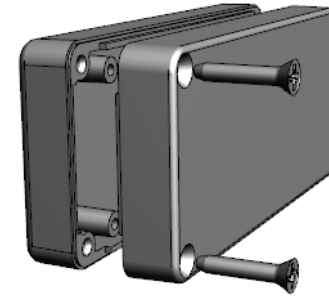
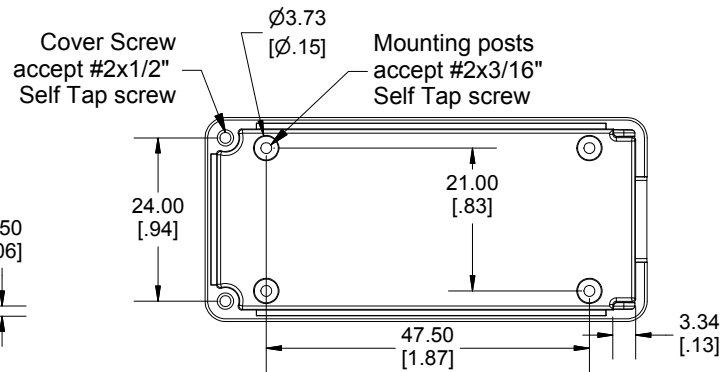
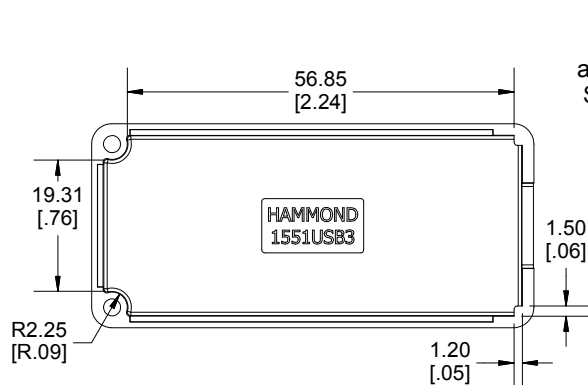
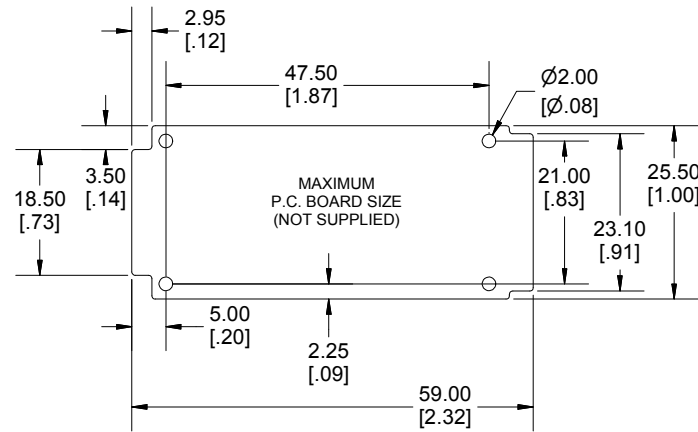

Enclosures can be Factory Modified ( Milling, Drilling, Printing etc.)  
 Contact Factory [mjm@hammondmfg.com](mailto:mjm@hammondmfg.com) for quotes  
 Solid models of this enclosure available in STEP or IGES.  
 (Part number and text placement/orientation on our products are subject to change,  
 we do not recommend using them as a locating reference for modification purposes)

**NOTE**

Purchased assembly includes box, lid, 2 cover screws.  
 Enclosure molded from general purpose ABS Plastic.  
 Other materials / colours available consult factory.

**Recommended Torque : (35-43) Ozf.in / (25-30) cN.m**

**PART NUMBERS**

1551USB3 Enclosure	
Black Enclosure - Ral 9011 - UL94 - HB	1551USB3BK
Gray Enclosure - RAL 7035 - UL94 - HB	1551USB3GY
Translucent Blue - UL94 - HB	1551USB3TBU
Translucent Clear - UL94 - HB	1551USB3CLR
Translucent Smoke - UL94 - HB	1551USB3TSK
Translucent Red - UL94 - HB	1551USB3TRD
ACCESSORIES	
P.C. Board Plastite Self Tapping Screw	1553WTS100 (Pkg 100)
Black Cover Screws #2 X 1/2" Self-tapping	1551USB50BK (Pkg 50)
P.C. Board Screws	1551ATS50 (Pkg 50)
#2 x 3/16" self-tapping (4.8mm)	1551ATS100 (Pkg 100)



Dimensions:  
 mm  
 [inches]