

THIS DRAWING IS UNPUBLISHED. RELEASED FOR PUBLICATION
 © COPYRIGHT - By - ALL RIGHTS RESERVED.

LOC	DIST	REVISIONS					
		P	LTR	DESCRIPTION	DATE	DWN	APVD
AF	50		E5	REVISED PER ECR-15-011170	07AUG2015	GRZ	JL

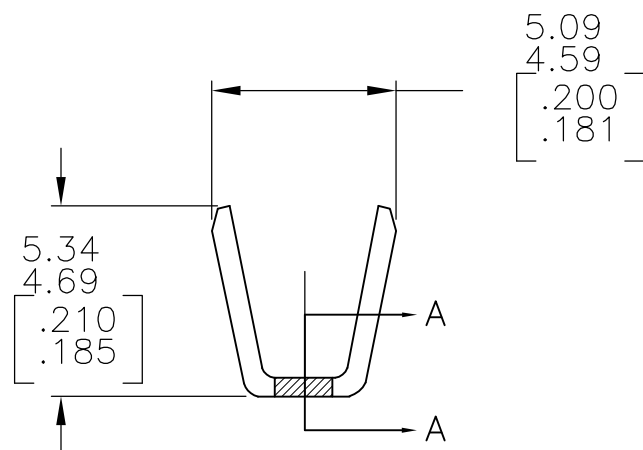
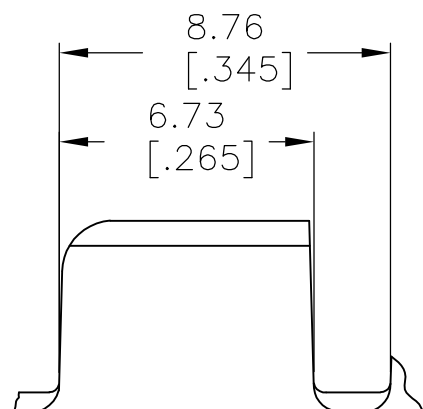
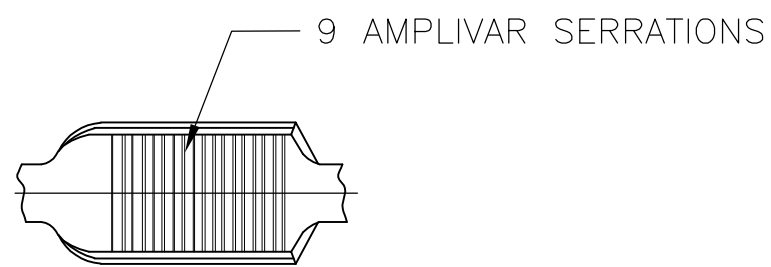

1. PRODUCT PROVIDED IN STRIP FORM ON REELS; BREAKS MAY BE PRESENT.
2. DIMENSIONS IN BRACKETS ARE IN INCHES.
3. CRIMP WIDTH: .140 F (AMPLIVAR TYPE)
 CRIMP HEIGHT (±.002)=(TOTAL CMA+14,600)/243,900

 CRIMP WIDTH: .180 F (AMPLIVAR TYPE)
 CRIMP HEIGHT (±.002)=(TOTAL CMA+15,000)/286,000

GENERAL APPLICATION GUIDELINES MUST BE FOLLOWED AS SPECIFIED IN CATALOG #82221
 FOR APPLICATOR INFORMATION CALL: 1-800-722-1111
 FOR PRODUCT INFORMATION CALL: 1-800-522-6752

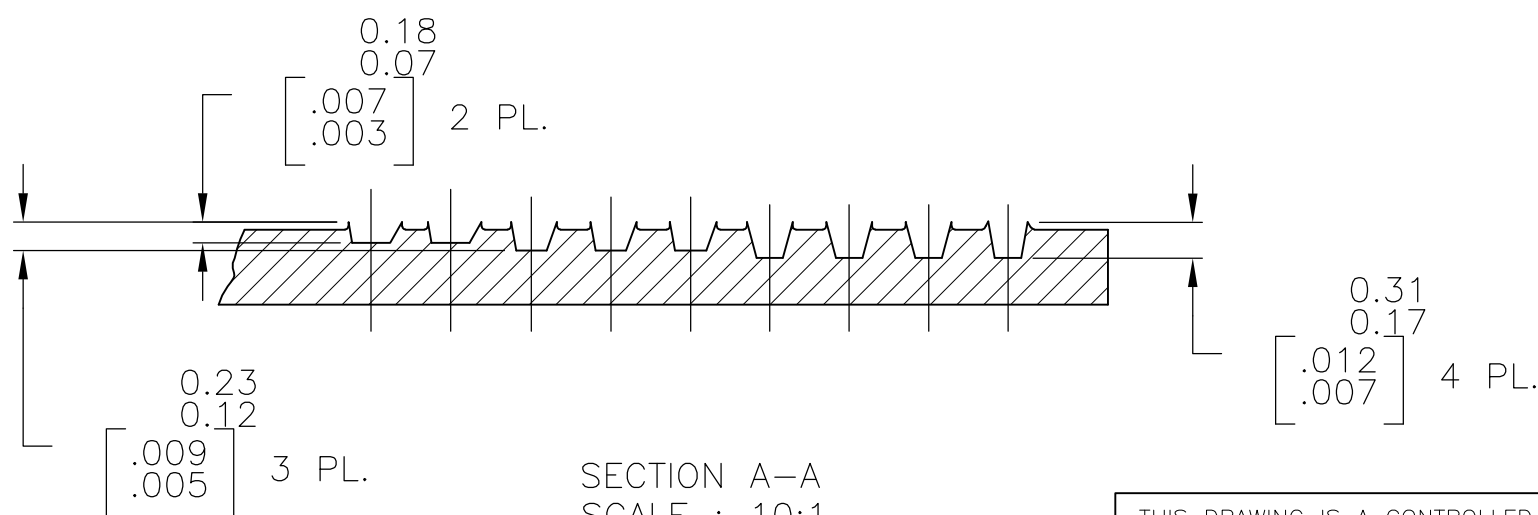

62308-2
 PART NO



THIS DRAWING IS A CONTROLLED DOCUMENT.		DWN RAGHAVENDRA 30JAN06	STE TE Connectivity	
DIMENSIONS: mm [INCHES]		CHK G.D.PORTA		
TOLERANCES UNLESS OTHERWISE SPECIFIED:		APVD G.D.PORTA	NAME	
0 PLC ± -		PRODUCT SPEC	SPLICE, AMPLIVAR	
1 PLC ± -		APPLICATION SPEC	3000-7000 CMA	
2 PLC ± 0.38[.015]		114-2003	SIZE A3	CAGE CODE 00779
3 PLC ± -		WEIGHT -	DRAWING NO C-62308	RESTRICTED TO -
4 PLC ± -		CUSTOMER DRAWING	SCALE 5:1	SHEET 1 OF 1
ANGLES ± 1°			REV E5	
FINISH TIN PL.				
MATERIAL REF 0.51±0.03 [.020±.001] BRASS				