

THIS DRAWING IS UNPUBLISHED. RELEASED FOR PUBLICATION 20
 © COPYRIGHT 20 BY - ALL RIGHTS RESERVED.

LOC		DIST		REVISIONS			
P	LTR	DESCRIPTION	DATE	DWN	APVD		
	A4	REVISED PER ECR-15-012863	02SEP2015	RS	PO		
	A5	REVISED PER ECR-15-015014	15OCT2015	RS	DD		
	A6	REVISED PER ECR-16-002072	18FEB2016	RS	DD		
	A7	REVISED PER ECR-16-006606	10MAY2016	RS	DD		

NOTES:

1. MATERIALS:
HOUSING: GLASS-FILLED THERMOPLASTIC, UL 94V-0 RATED DIMMING CONTACTS (2 OR 4) AND LINE VOLTAGE CONTACTS (3): COPPER ALLOY
2. FINISH:
DIMMING CONTACTS (2 OR 4): NICKEL UNDERPLATE ENTIRE CONTACT 0.127 µm MIN THICK. GOLD PLATE CONTACT PAD AREA (MATING FACE SIDE ONLY) 0.76 µm MIN THICK. MATTE TIN PLATE TAB ON BOTH SIDES 0.30 µm MIN THICK. LINE VOLTAGE CONTACTS (3): TIN PLATE.
3. LINE VOLTAGE CONDUCTORS (3):
14 AWG, 600V, 150°C RATED, COPPER 41/30 STRANDED PER UL STYLE AWM 3321.
4. MATING INTERFACE PER ANSI C136.41-2013.
5. OPTIONAL DIMMING CONTACTS (2) SUPPLIED.
6. DIMMING CONDUCTORS (2 OR 4):
18 AWG, 600V, 150°C RATED, 16/30 STRANDED, PER UL STYLE AWM 3321.
7. LINE VOLTAGE CONDUCTORS (3):
14 AWG, 600V, 105°C RATED, COPPER 41/30 STRANDED. PER UL STYLE AWM 1015.
8. DIMMING CONDUCTORS (2 OR 4):
18 AWG, 600V, 105°C RATED, COPPER 16/30 STRANDED. PER UL STYLE AWM 1015.
9. LUBRICATION: GOLD PLATED CONTACT PAD SURFACES OF DIMMING CONTACTS ARE LUBRICATED WITH A TRANSPARENT (NON-VISIBLE) LUBRICANT TO IMPROVE DURABILITY AND PERFORMANCE. AVOID CONTACT WITH THESE SURFACES WHICH MAY RESULT IN REMOVAL OF LUBRICANT.

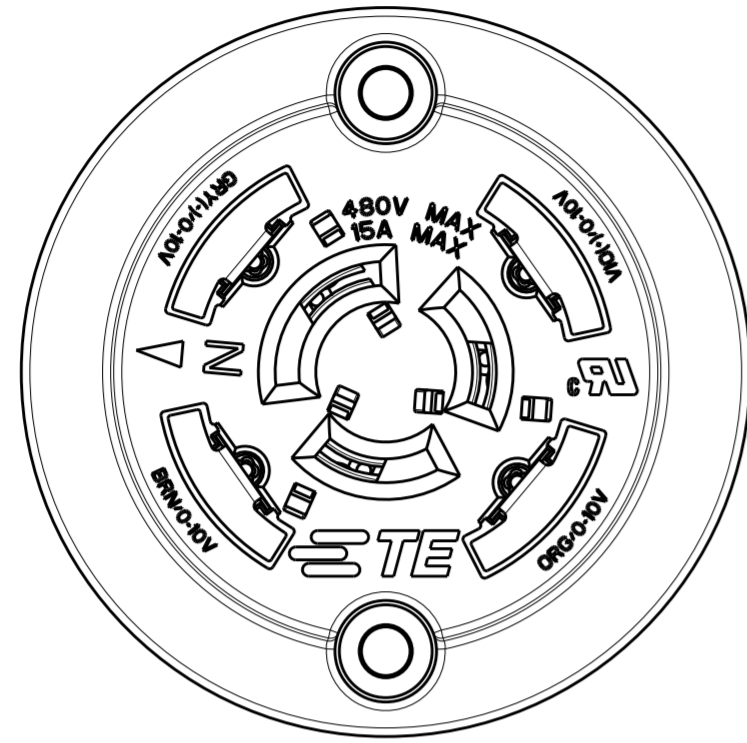

SEE SHEET 2 FOR WIRING COLOR CODE

10. PRELIMINARY.

1865.1	1828.8	1815.3	3 AND 6	2	3-2213362-1 10
736.3	700.0	686.5	7 AND 8	4 5	2-2213362-4
696.3	660.0	646.5	3 AND 6	4 5	2-2213362-2 10
696.3	660.0	646.5	3 AND 6	2	2-2213362-1
536.3	500.0	486.5	7 AND 8	4 5	1-2213362-4
536.3	500.0	486.5	7 AND 8	2	1-2213362-3 10
536.3	500.0	486.5	3 AND 6	2	1-2213362-1 10
341.1	304.8	291.3	7 AND 8	4 5	2213362-4
341.1	304.8	291.3	7 AND 8	2	2213362-3
341.1	304.8	291.3	3 AND 6	4 5	2213362-2
341.1	304.8	291.3	3 AND 6	2	2213362-1
C	A	B	WIRE STYLE	QUANTITY OF DIMMING CONTACTS	PART NO.
OVERALL LENGTH	WIRE LENGTH				

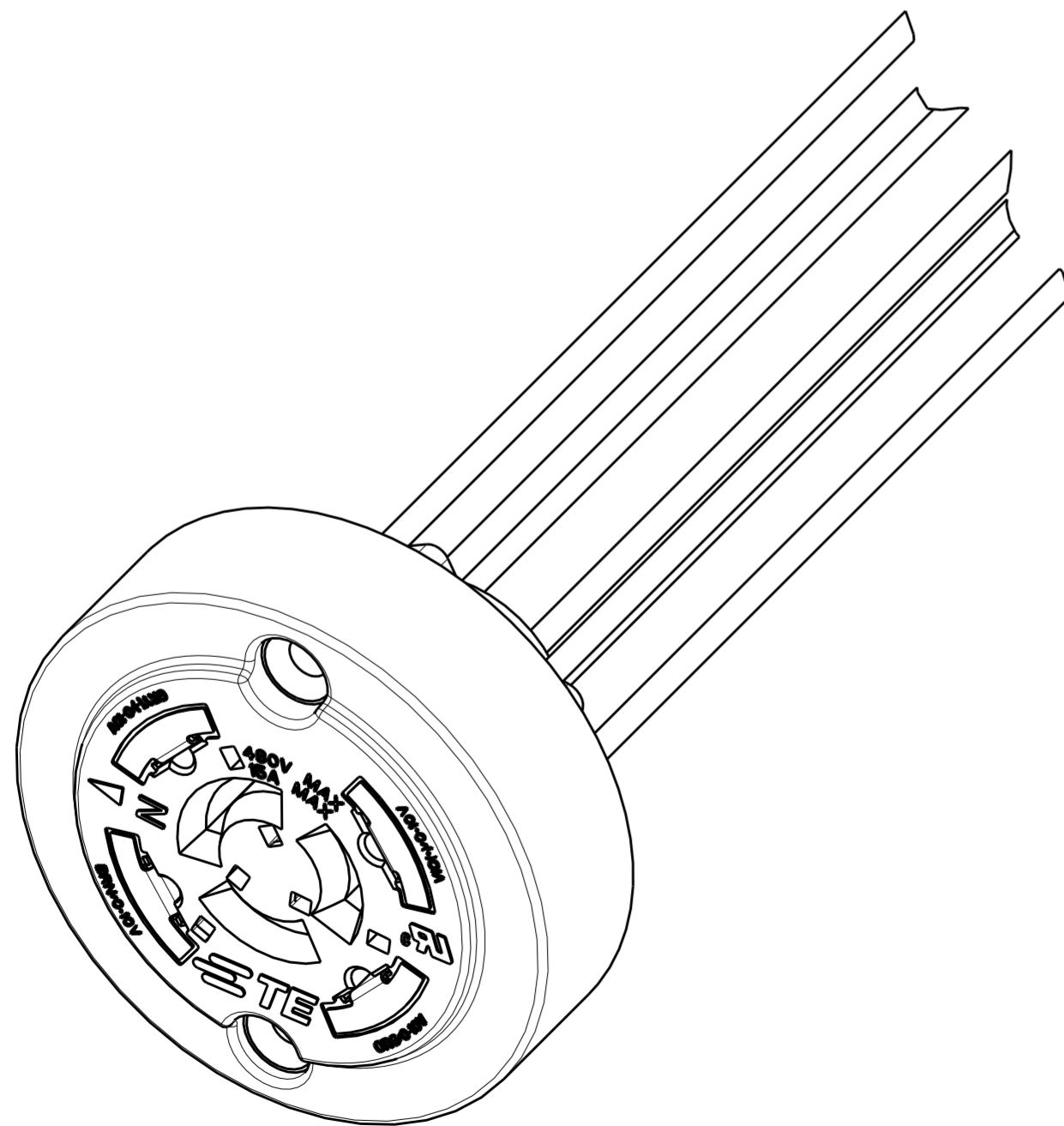

THIS DRAWING IS A CONTROLLED DOCUMENT.

DWN	J. SHAFFER	26 JUN 2013
CHK	E. HOWARD	26 JUN 2013
APVD	E. HOWARD	26 JUN 2013

STE TE Connectivity

NAME: RECEPTACLE ASSEMBLY, DIMMABLE PHOTOCONTROL

PRODUCT SPEC: 108-32059

APPLICATION SPEC: 114-32115

SIZE: A2 CAGE CODE: 00779 DRAWING NO: C-2213362

RESTRICTED TO: -

CUSTOMER DRAWING SCALE: 1:1 SHEET 1 OF 2 REV A7

4

3

2

1

THIS DRAWING IS UNPUBLISHED. RELEASED FOR PUBLICATION 20
 © COPYRIGHT 20 BY - ALL RIGHTS RESERVED.

LOC	DIST	REVISIONS			
P	LTR	DESCRIPTION	DATE	DWN	APVD
-	-	SEE SHEET 1	-	-	-

(-) DIMMING CONTACT, GREY WIRE
SEE TABLE FOR QUANTITY

Li (BLACK WIRE)

(+) DIMMING CONTACT, VIOLET WIRE

NEUTRAL (WHITE WIRE)

OPTIONAL DIMMING CONTACT (-2 AND -4 ONLY), BROWN WIRE

Lo (RED WIRE)

OPTIONAL DIMMING CONTACT (-2 AND -4 ONLY), ORANGE WIRE

Ø 4.29

Ø 64.26

24.61 2X

1.73

17.32

38.00

C +12.7
-6.4

A +12.7
-6.4

B +12.7
-6.4

Ø 34.70

THIS DRAWING IS A CONTROLLED DOCUMENT.		DWN J. SHAFFER 26 JUN 2013	TE Connectivity	
DIMENSIONS: mm		CHK E. HOWARD 26 JUN 2013		
TOLERANCES UNLESS OTHERWISE SPECIFIED:		APVD E. HOWARD 26 JUN 2013	NAME RECEPTACLE ASSEMBLY, DIMMABLE PHOTOCONTROL	
0 PLC ± 1 PLC ± 2 PLC ±0.13 3 PLC ± 4 PLC ± ANGLES ± FINISH -		PRODUCT SPEC 108-32059	SIZE A200779	
MATERIAL		APPLICATION SPEC 114-32115	DRAWING NO C-2213362	
		WEIGHT	RESTRICTED TO	
		Customer Drawing	SCALE 1:1 SHEET 2 OF 2 REV A7	

1471-9 (3/11)