

M-6565 3

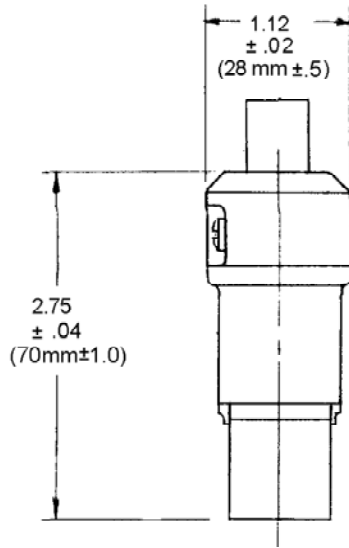

CORD GUARD SHOWN IN EXTENDED POSITION

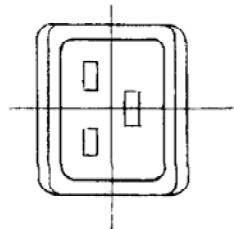
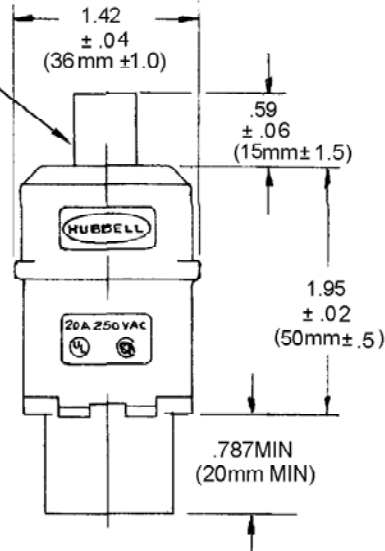

LIST OF PARTS		
DESCRIPTION	MATERIAL	FINISH
HOUSING	NYLON	BLACK
CONTACT SPRING	BRASS	
WIRE CLAMPING NUT	STEEL	NICKEL PL.
BINDING SCREW	STAIN. STEEL	BLACK
GR. BINDING SCREW	STAIN. STEEL	GREEN
CORD CLAMP SCREW	STEEL	ZINC PL.
CORD GUARD	RUBBER	BLACK

3	.787 WAS 7.87 PER DCN 19209 SPN	DJP	11/29/12
2	.787 MIN WAS .813 +/- .015 ALL OTHER DIMS REVISED 3 DECIMAL PLACES TO TWO PER DCN 18611 SPN	DJP	1-30-12
1	CONVERTED ALL DIMS TO 3 PL DECIMAL & TOL ADDED PER DCN #7773 AMZ DB		7-10-00

CORD ACCOMMODATION  
NORTH AMERICAN  
16/3 SJ - 12/3 SJ (.325 - .475 DIA.)  
INTERNATIONAL (HAR CORD)  
3 X 1.5 mm<sup>2</sup> - 3 - 2.5 mm<sup>2</sup> (8MM - 12mm DIA.)

CAT. NO H320C

TITLE  
20/16A 250V A.C. THREE - WIRE  
I.E. C. STRAIGHT BLADE VALISE  
CONNECTOR

SYM REVISIONS APP DATE

THE DESIGN AND DIMENSIONS OF THE PRODUCT SHOWN ON THIS DRAWING ARE SUBJECT TO CHANGE WITHOUT NOTICE.

TOLERANCES UNLESS OTHERWISE SPECIFIED	WIRING DEVICE DIVISION HARVEY HUBBELL, INC. BRIDGEPORT, CONN.	
FRACTIONS ± 1/64	DR. BY <u>A.J.L.</u>	APP. BY
DECIMALS ± .005	TR. BY	SCALE <u>FULL</u>
ANGLES ± 2°	CHK'D. BY	DATE <u>6-7-87</u>

CODE 74545

DIMENSION SHEET FOR CAT. NO. H320C

REPAIRABLE  NON-REPAIRABLE

B

M-6565

3