

GCT USB4050 is designed and manufactured to be compatible with USB Type C specification latest release. Compliance testing for products conforming to the USB type-C cable and connector specification are currently under development by the USB-IF.

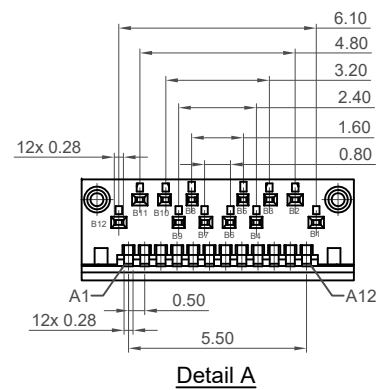
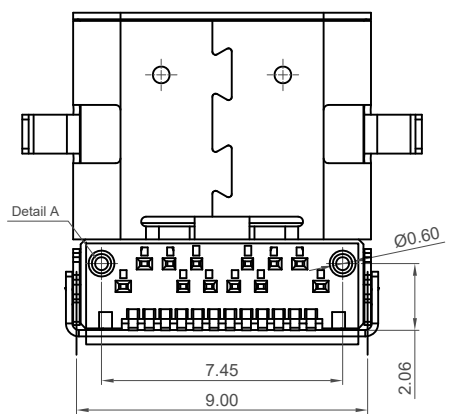
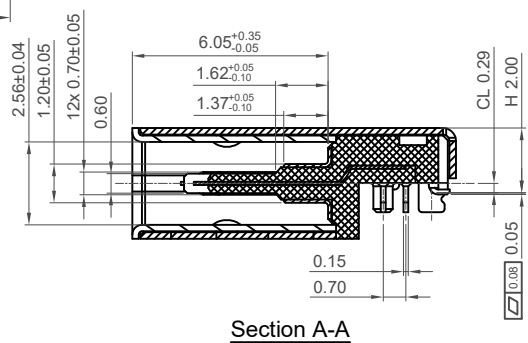
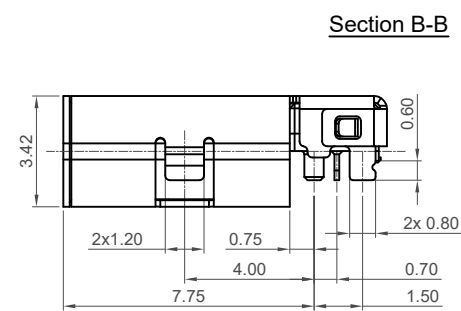
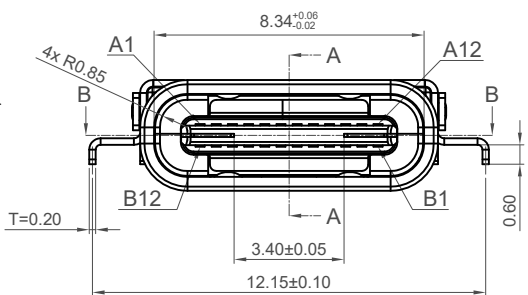
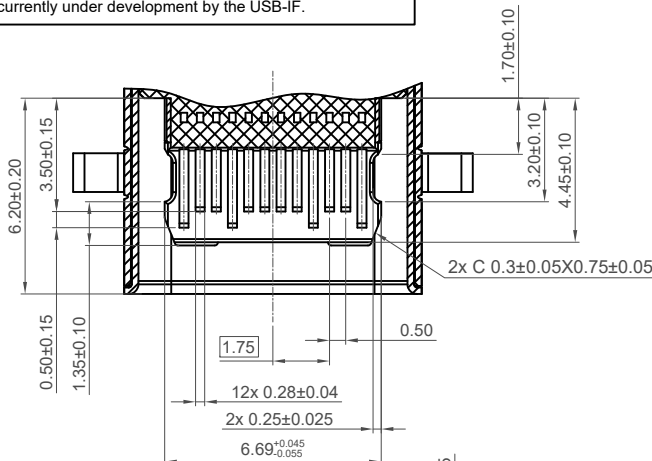

Pin	Signal	Mating Sequence	Pin	Signal	Mating Sequence
A1	GND	First	B12	GND	First
A2	SSTXp1	Second	B11	SSRXp1	Second
A3	SSTXn1	Second	B10	SSRXn1	Second
A4	Vbus	First	B9	Vbus	First
A5	CC1	Second	B8	SBU2	Second
A6	Dp1	Second	B7	Dn2	Second
A7	Dn1	Second	B6	Dp2	Second
A8	SBU1	Second	B5	CC2	Second
A9	Vbus	First	B4	Vbus	First
A10	SSRXn2	Second	B3	SSTXn2	Second
A11	SSRXp2	Second	B2	SSTXp2	Second
A12	GND	First	B1	GND	First
SHELL	GND		SHELL	GND	

Specifications 规格

Material 物料
 Insulator: High Temp. Plastic UL 94V-0, Black
 Contact: High Grade Copper Alloy (T=0.15mm)
 Shell: Stainless steel (T=0.20mm)
 Cover Shell: Iron (T=0.20mm)
 Inner Ground Cover Shell: Stainless Steel (T=0.10mm)
 Mid Plate: Stainless Steel (T=0.10mm)

Plating 电镀
 Contact: 30µ" Gold over 50µ" min. Nickel
 Solder Tails: 80µ" min. Matte Tin over 50µ" min. Nickel
 Shell: 50µ" min. Nickel
 Cover Shell: 80µ" min. Nickel
 Inner Ground Cover Shell: 50µ" min. Nickel

Electrical 电气
 Current Rating: 5.00A collectively for Vbus pins
 6.25A collectively for GND pins
 1.25A for B5 pin
 0.25A per pin for all other pins
 Voltage Rating: 20V DC
 Contact Resistance: 40mΩ max initial.
 50mΩ max after test
 Dielectric Withstanding Voltage: 100V AC
 Insulation Resistance 100MΩ min

Mechanical & Environmental 机械 & 环境
 Operating Temperature: -40°C to 85°C
 Mating Force: 5 to 20 N.
 Unmated Force: 8 to 20 N after test
 Durability: 10,000 cycles

Ordering Grid
USB4050 - **30** - **A** Request Samples and Quotation

Contact Plating
 30 = 30µ" Gold

Packing Options
 A = Tape & Reel
 (1,250 per reel)

Part Number USB4050		Product Description USB Type C Receptacle Hybrid type, PCB Mid Mount, 1.00mm Offset			This drawing is confidential and copyright of Global Connector Technology, Ltd (GCT). This drawing must not be copied or disclosed without written consent. E & OE
Drawing Date 21st April 2016					
By AJO	Detail Drawing Release	Tolerances (Except as Noted) Length X. ± 0.50 X.X ± 0.30 X.XX ± 0.20 X.XXX ± 0.10	Units: Metric (mm)		Not to Scale
Revision A	Date 21/04/16	Angle ± 2°			

GCT
 Global Connector Technology
 www.gct.co

Not to Scale | Drawn By AJO | Sheet No. 1/3

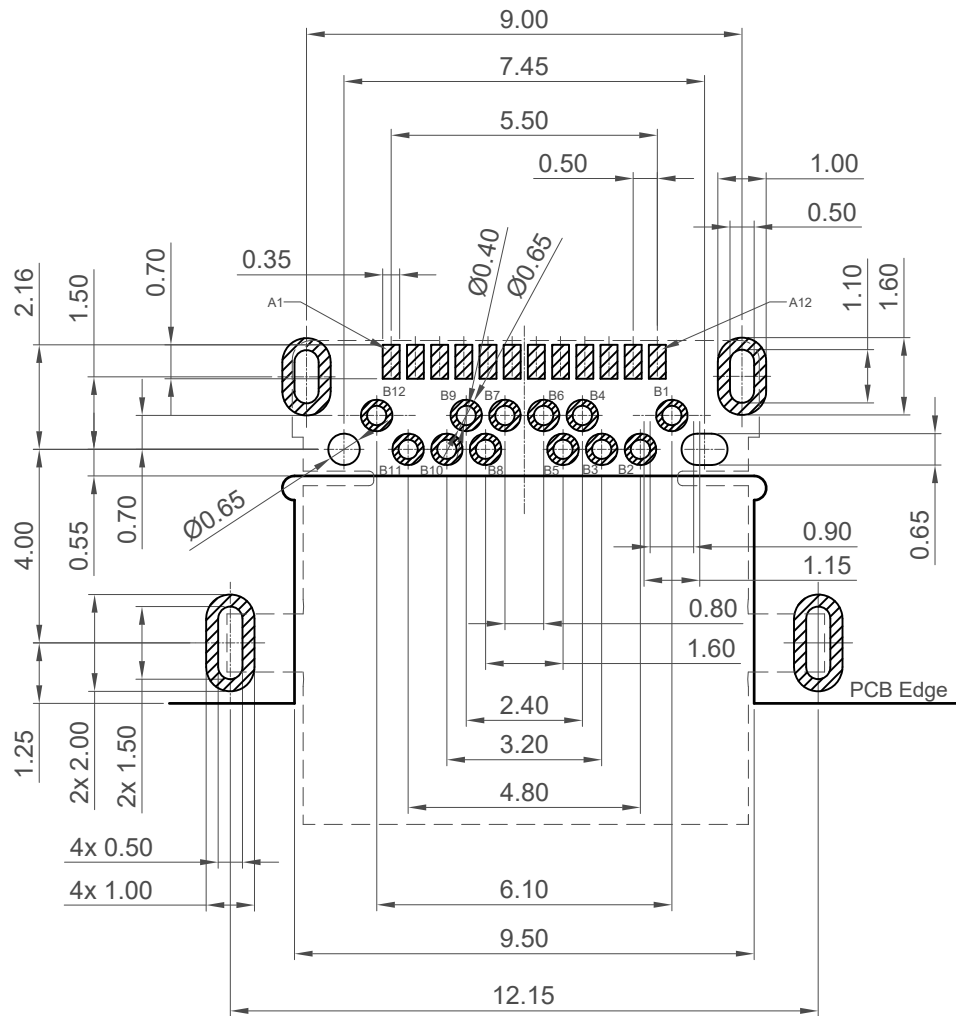

Recommended PCB Layout

As viewed from component side Tolerance: $\pm 0.05\text{mm}$

Recommended PCB Thickness: 0.60mm

Solder Area Component Outline

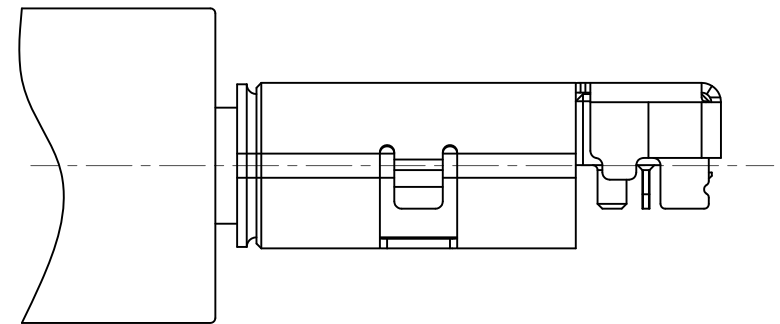
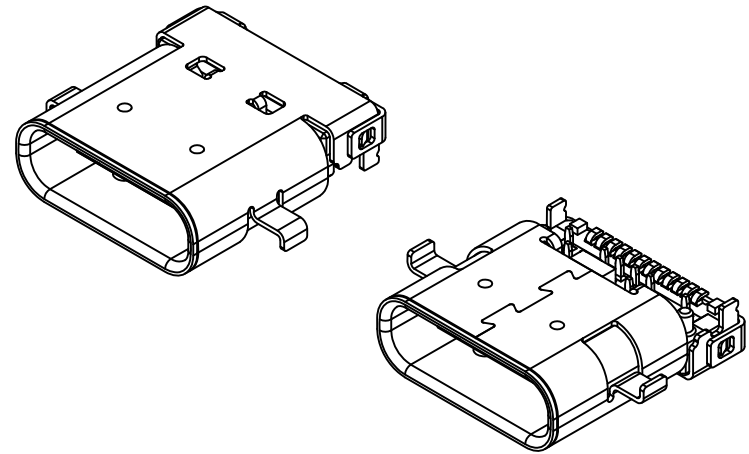

Mating View

Part Number		Product Description			This drawing is confidential and copyright of Global Connector Technology, Ltd (GCT). This drawing must not be copied or disclosed without written consent. E & OE
USB4050		USB Type C Receptacle			
Drawing Date		Hybrid type, PCB Mid Mount, 1.00mm Offset			
21st April 2016					Not to Scale Drawn By AJO Sheet No. 2/3
By	AJO	Tolerances (Except as Noted)	Units:		
Detail	Drawing Release	Length	Metric (mm)		
Revision	A	Angle	$\pm 2^\circ$		
Date	21/04/16	X. ± 0.50			
		X.X ± 0.30			
		X.XX ± 0.20			
		X.XXX ± 0.10			

GCT
Global Connector Technology
www.gct.co

38.4
32.4

Label

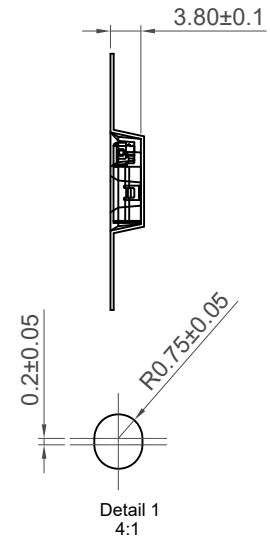
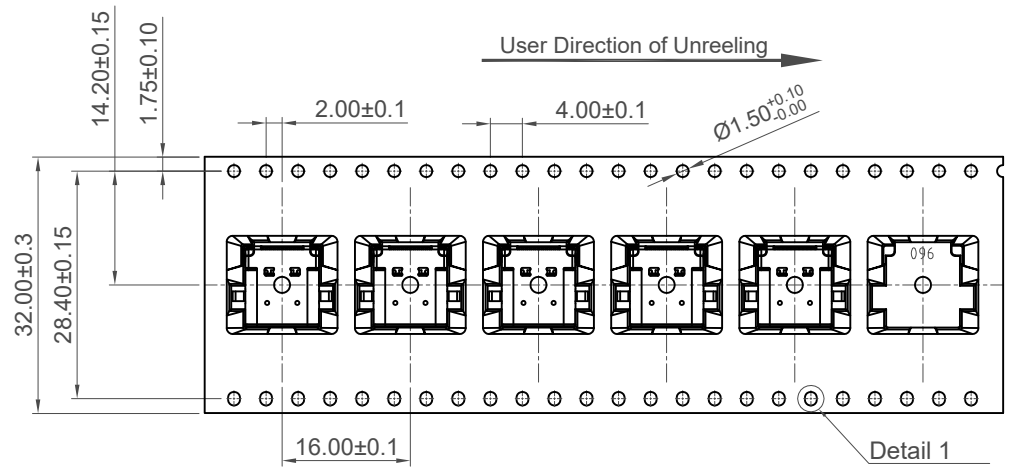
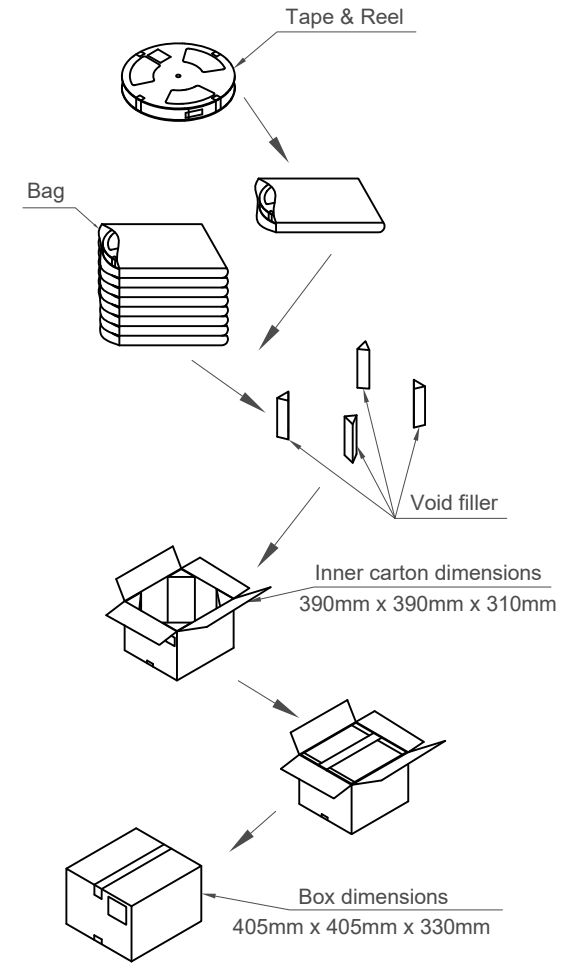
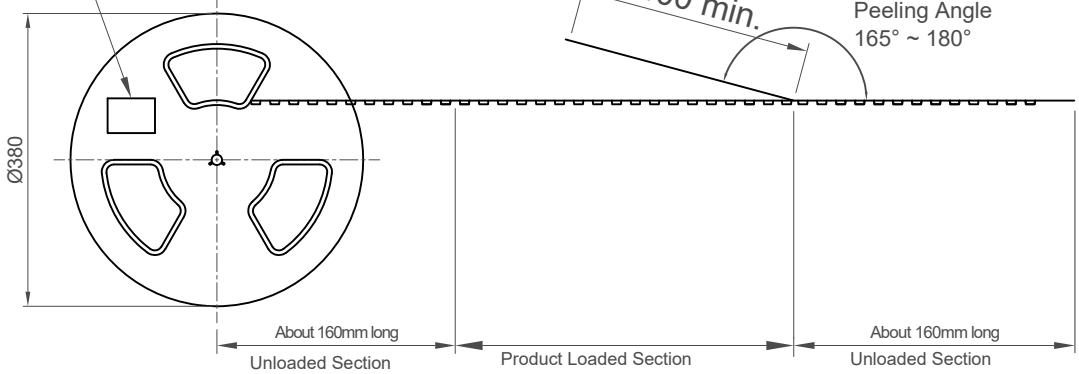

Note:

1. Material:
 - Box: Fibreboard, corrugated, double wall.
 - Tape: Polystyrene, heat-resistant temperature: 120°C, Black colour.
 - Reel: Polystyrene, heat-resistant temperature: 70°C, Blue colour.
 - Bag: Polyethylene, heat-resistant temperature: 100°C.

2. Peeling strength: 0.1 ~ 1.3 N (10 ~ 130 grams)

3. Peeling speed: 300 mm/min.

4. Each bag includes desiccant.

Pcs / Reel	Reels / Carton	Total Quality
1250	8	10,000 pcs

Part Number		Product Description	
USB4050		USB Type C Receptacle	
Drawing Date		Hybrid type, PCB Mid Mount, 1.00mm Offset	
21st April 2016			
By	AJO	Tolerances (Except as Noted)	Units:
Detail	Drawing Release	Length	Metric (mm)
Revision	A	X. ± 0.20	
Date	21/04/16	X.X ± 0.15	
		X.XX ± 0.10	
		X.XXX ± 0.05	 3rd Angle Projection
		Angle	 This drawing is confidential and copyright of Global Connector Technology, Ltd (GCT). This drawing must not be copied or disclosed without written consent. E & OE

GCT
Global Connector Technology
www.gct.co

Not to Scale	Drawn By AJO	Sheet No. 3/3
--------------	--------------	---------------

H
G
F
E
D
C
B
A

1 2 3 4 5 6 7 8