

CODE NO.	CONTACT	A	B	C	D	E	F	G	H	J
CL683-0253-2-57	26	11.5	8.3	7	6	11.3	9.7	8.5	11.9	9.1
CL683-0268-0-57	30	12.5	9.3	8	7	12.3	10.7	9.5	12.9	10.1
CL683-0361-5-57	60	20	16.8	15.5	14.5	19.8	18.2	17	20.4	17.6
CL683-0393-1-57	70	22.5	19.3	18	17	22.3	20.7	19.5	22.9	20.1
CL683-0369-7-57	80	25	21.8	20.5	19.5	24.8	23.2	22	25.4	22.6

NOTES 1 : LEAD CO-PLANARITY INCLUDE REINFORCED METAL FITTINGS SHALL BE 0.1mm MAX.
 2 IF THE RESIST PROCESSING HAS NOT MADE, IT HAS POSSIBILITY THAT THE TERMINAL TOUCHES WITH AREA. PLEASE BE NOTED THIS POINT.

NO.	MATERIAL	FINISH . REMARKS	NO.	MATERIAL	FINISH . REMARKS
7	PS	CLEAR (REINFORCEMENT COLLAR)	7	PS	CLEAR (REINFORCEMENT COLLAR)
6	PS	BLACK (PLASTIC REEL)	6	PS	BLACK (PLASTIC REEL)
5	POLYESTER	CLEAR (COVER TAPE)	5	POLYESTER	CLEAR (COVER TAPE)
4	PS	CLEAR (EMBOSSED CARRIER TAPE)	4	PS	CLEAR (EMBOSSED CARRIER TAPE)
3	PHOSPHER BRONZE	TIN PLATED 1µm min UNDER PLATING : NICKEL 1µm min	3	PHOSPHER BRONZE	TIN PLATED 1µm min UNDER PLATING : NICKEL 1µm min

UNITS	SCALE	COUNT	DESCRIPTION OF REVISIONS	DESIGNED	CHECKED	DATE
mm	5 : 1	△	APPROVED : KH. IKEDA 11.12.19			
			CHECKED : TS. MIYAZAKI 11.12.19			
			DESIGNED : TR. YUNOKI 11.12.19			
			DRAWN : MS. SATO 11.12.19			

DRAWING NO.	PART NO.	CODE NO.
EDC3-162761-77	DF17(3.0H)*DS-0.5V(57)	CL683

Aug.1.2016 Copyright 2016 HIROSE ELECTRIC CO., LTD. All Rights Reserved.

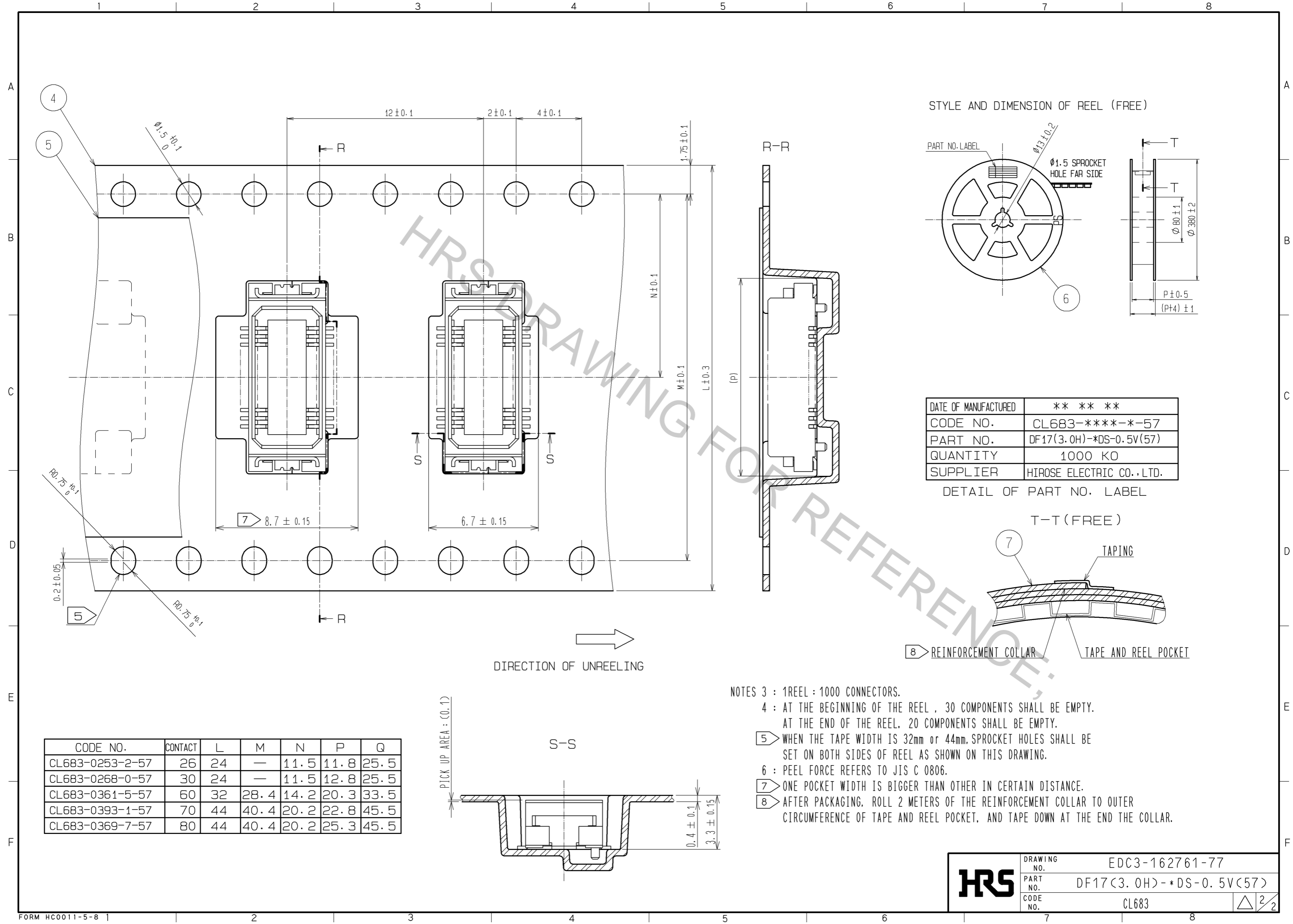

STYLE AND DIMENSION OF REEL (FREE)

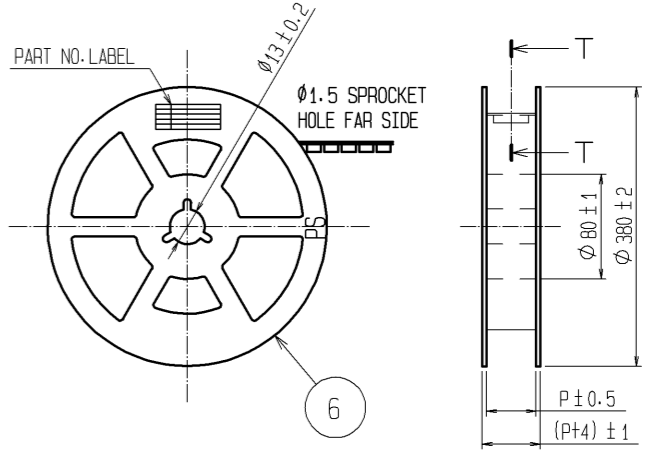

DATE OF MANUFACTURED	** ** *
CODE NO.	CL683-****-*57
PART NO.	DF17(3.0H)-*DS-0.5V(57)
QUANTITY	1000 KO
SUPPLIER	HIROSE ELECTRIC CO., LTD.

CODE NO.	CONTACT	L	M	N	P	Q
CL683-0253-2-57	26	24	—	11.5	11.8	25.5
CL683-0268-0-57	30	24	—	11.5	12.8	25.5
CL683-0361-5-57	60	32	28.4	14.2	20.3	33.5
CL683-0393-1-57	70	44	40.4	20.2	22.8	45.5
CL683-0369-7-57	80	44	40.4	20.2	25.3	45.5

- NOTES 3 : 1REEL : 1000 CONNECTORS.
- 4 : AT THE BEGINNING OF THE REEL , 30 COMPONENTS SHALL BE EMPTY.
AT THE END OF THE REEL, 20 COMPONENTS SHALL BE EMPTY.
- 5 WHEN THE TAPE WIDTH IS 32mm or 44mm, SPROCKET HOLES SHALL BE SET ON BOTH SIDES OF REEL AS SHOWN ON THIS DRAWING.
- 6 : PEEL FORCE REFERS TO JIS C 0806.
- 7 ONE POCKET WIDTH IS BIGGER THAN OTHER IN CERTAIN DISTANCE.
- 8 AFTER PACKAGING, ROLL 2 METERS OF THE REINFORCEMENT COLLAR TO OUTER CIRCUMFERENCE OF TAPE AND REEL POCKET, AND TAPE DOWN AT THE END THE COLLAR.

HRS	DRAWING NO.	EDC3-162761-77
	PART NO.	DF17(3.0H)-*DS-0.5V(57)
	CODE NO.	CL683
		△ 2/2