

Aug.1.2016 Copyright 2016 HIROSE ELECTRIC CO., LTD. All Rights Reserved.

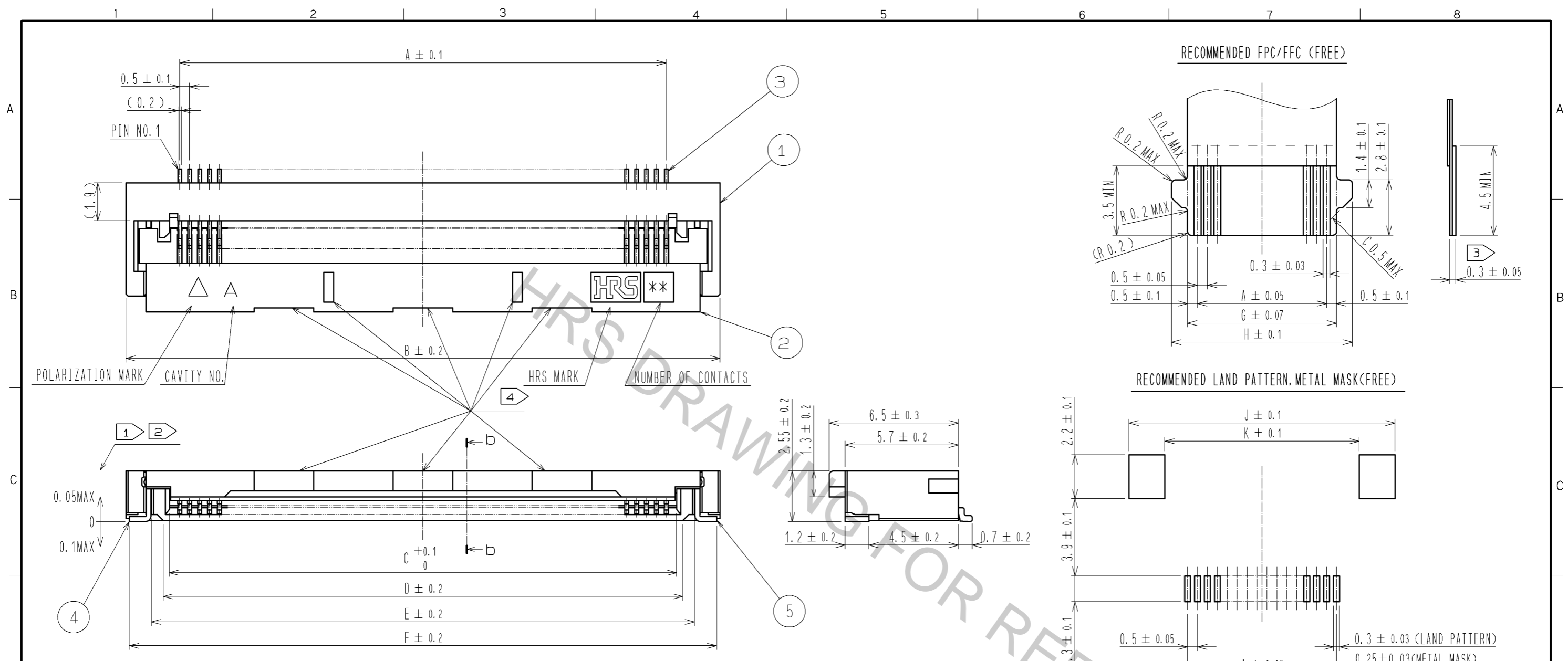

- NOTE
- 1 REFERENCE IS a.
  - 2 LEAD CO-PLANARITY SHALL BE 0.1 MAX.
  - 3 THICKNESS OF SUPPORTING TAPE SHALL BE 0.188(7.5mil) MIN.
  - 4 INDICATES NOTCHES OR HOLES TO PREVENT SINK MARKS. THE DESIGN AND THE LOCATION ARE DISCRETIONARY, DEPENDING ON THE NUMBER OF CONTACTS.
  - 5 THIS PRODUCT SATISFIES HALOGEN FREE REQUIREMENTS DEFINED AS 900 PPM MAXIMUM CHLORINE, 900 PPM MAXIMUM BROMINE, AND 1500 PPM MAXIMUM TOTAL OF CHLORINE AND BROMINE.

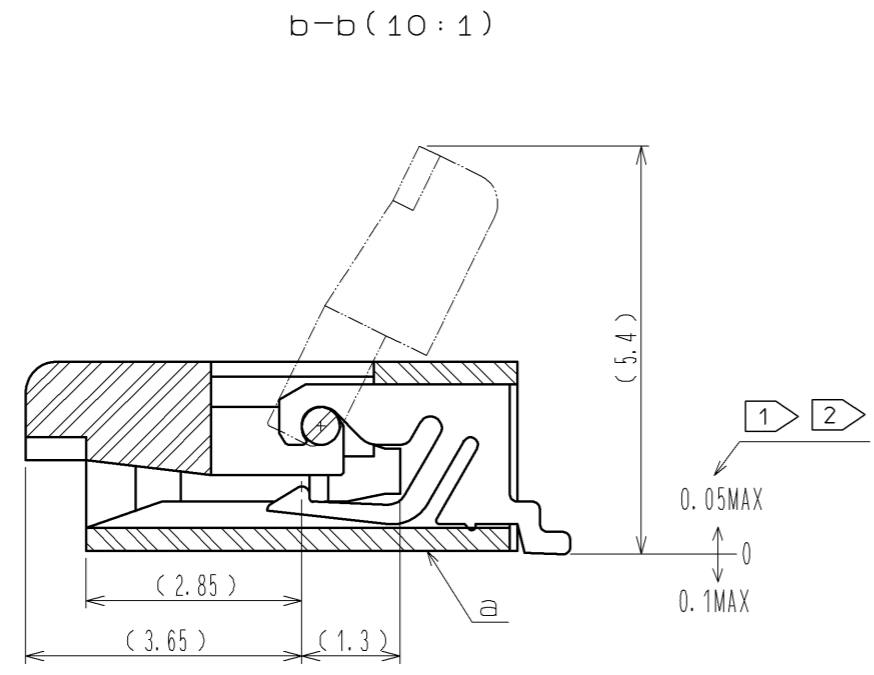

5	BRASS	TIN PLATING 1#MMIN OVER NICKEL 1#MMIN						
4	BRASS	TIN PLATING 1#MMIN OVER NICKEL 1#MMIN	9	(CONNECTOR)				
3	PHOSPHOR BRONZE	GOLD PLATING 0.05#MMIN OVER NICKEL 1#MMIN	8	POLYSTYRENE				
2	LCP	(BLACK) UL94V-0	7	POLYESTER				
1	LCP	(GRAY) UL94V-0	6	POLYSTYRENE				
NO.	MATERIAL	FINISH . REMARKS	NO.	MATERIAL	FINISH . REMARKS			
UNITS	mm	SCALE	5 : 1	COUNT	DESCRIPTION OF REVISIONS	DESIGNED	CHECKED	DATE
APPROVED : NM. NISHIMATSU		10.10.22		DRAWING NO.		EDC3-155415-08		
CHECKED : HS. SAKAMOTO		10.10.21		PART NO.		FH28D-**S-0.5SH(98)		
DESIGNED : TO. SHIBUYA		10.10.20		CODE NO.		CL586		
DRAWN : TO. SHIBUYA		10.10.20						

Aug.1.2016 Copyright 2016 HIROSE ELECTRIC CO., LTD. All Rights Reserved.

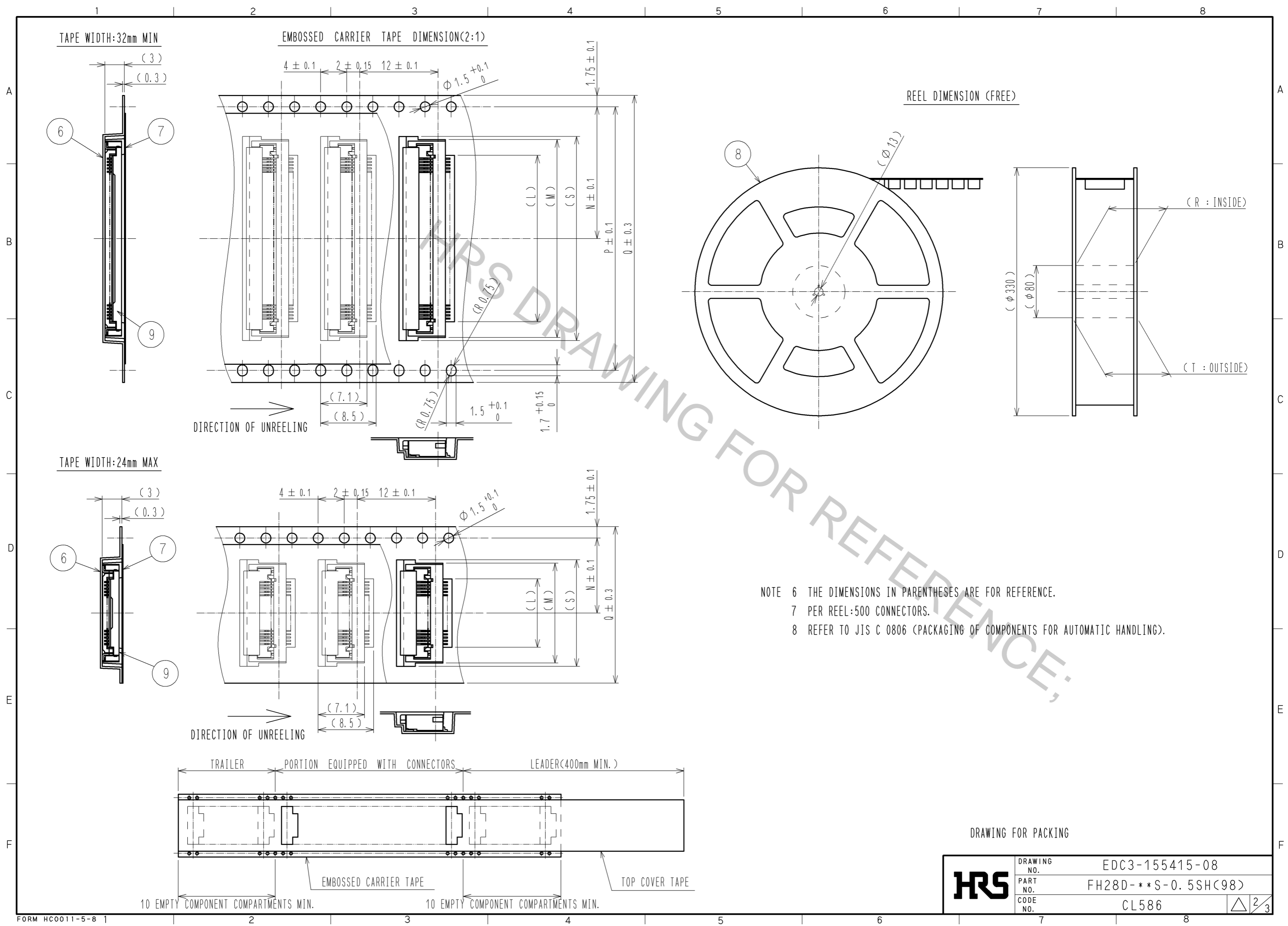

DRAWING FOR PACKING

<b>HRS</b>	DRAWING NO.	EDC3-155415-08
	PART NO.	FH28D-**S-0.5SH(98)
	CODE NO.	CL586
		$\triangle$ 2/3

DIMENSION TABLE OF CONNECTOR, FPC, FFC, LAND PATTERN AND METAL MASK

PART NO.	CODE NO.	*	A	B	C	D	E	F	G	H	J	K
FH28D-20S-0.5SH(98)	CL586-1823-5-98	20	9.5	14.9	10.57	11.15	12.35	14.58	10.5	12.1	15.6	12
FH28D-28S-0.5SH(98)	CL586-1835-4-98	28	13.5	18.9	14.57	15.15	16.35	18.58	14.5	16.1	19.6	16
FH28D-30S-0.5SH(98)	CL586-1827-6-98	30	14.5	19.9	15.57	16.15	17.35	19.58	15.5	17.1	20.6	17
FH28D-50S-0.5SH(98)	CL586-1808-1-98	50	24.5	29.9	25.57	26.15	27.35	29.58	25.5	27.1	30.6	27
FH28D-55S-0.5SH(98)	CL586-1821-0-98	55	27	32.4	28.07	28.65	29.85	32.08	28	29.6	33.1	29.5
FH28D-64S-0.5SH(98)	CL586-1813-1-98	64	31.5	36.9	32.57	33.15	34.35	36.58	32.5	34.1	37.6	34
FH28D-68S-0.5SH(98)	CL586-1819-8-98	68	33.5	38.9	34.57	35.15	36.35	38.58	34.5	36.1	39.6	36
FH28D-74S-0.5SH(98)	CL586-1828-9-98	74	36.5	41.9	37.57	38.15	39.35	41.58	37.5	39.1	42.6	39

DIMENSION TABLE OF DRAWING FOR PACKING

PART NO.	CODE NO.	*	L	M	N	P	Q	R	T	S
FH28D-20S-0.5SH(98)	CL586-1823-5-98	20	10.5	15.3	11.5	-	24	25.4	29.4	16.3
FH28D-28S-0.5SH(98)	CL586-1835-4-98	28	14.5	19.3	14.2	28.4	32	33.4	37.4	20.3
FH28D-30S-0.5SH(98)	CL586-1827-6-98	30	15.5	20.3	14.2	28.4	32	33.4	37.4	21.3
FH28D-50S-0.5SH(98)	CL586-1808-1-98	50	25.5	30.3	20.2	40.4	44	45.4	49.4	-
FH28D-55S-0.5SH(98)	CL586-1821-0-98	55	28	32.8	20.2	40.4	44	45.4	49.4	-
FH28D-64S-0.5SH(98)	CL586-1813-1-98	64	32.5	37.3	26.2	52.4	56	57.4	61.4	-
FH28D-68S-0.5SH(98)	CL586-1819-8-98	68	34.5	39.3	26.2	52.4	56	57.4	61.4	-
FH28D-74S-0.5SH(98)	CL586-1828-9-98	74	37.5	42.3	26.2	52.4	56	57.4	61.4	43.3

\* : NUMBER OF CONTACTS

<b>HRS</b>	DRAWING NO.	EDC3-155415-08
	PART NO.	FH28D-**S-0.5SH(98)
	CODE NO.	CL586
		△ 3/3