

Aug.1.2016 Copyright 2016 HIROSE ELECTRIC CO., LTD. All Rights Reserved.

COUNT	DESCRIPTION OF REVISIONS	BY	CHKD	DATE	COUNT	DESCRIPTION OF REVISIONS	BY	CHKD	DATE
△				..	△				..
△				..	△				..
△				..	△				..

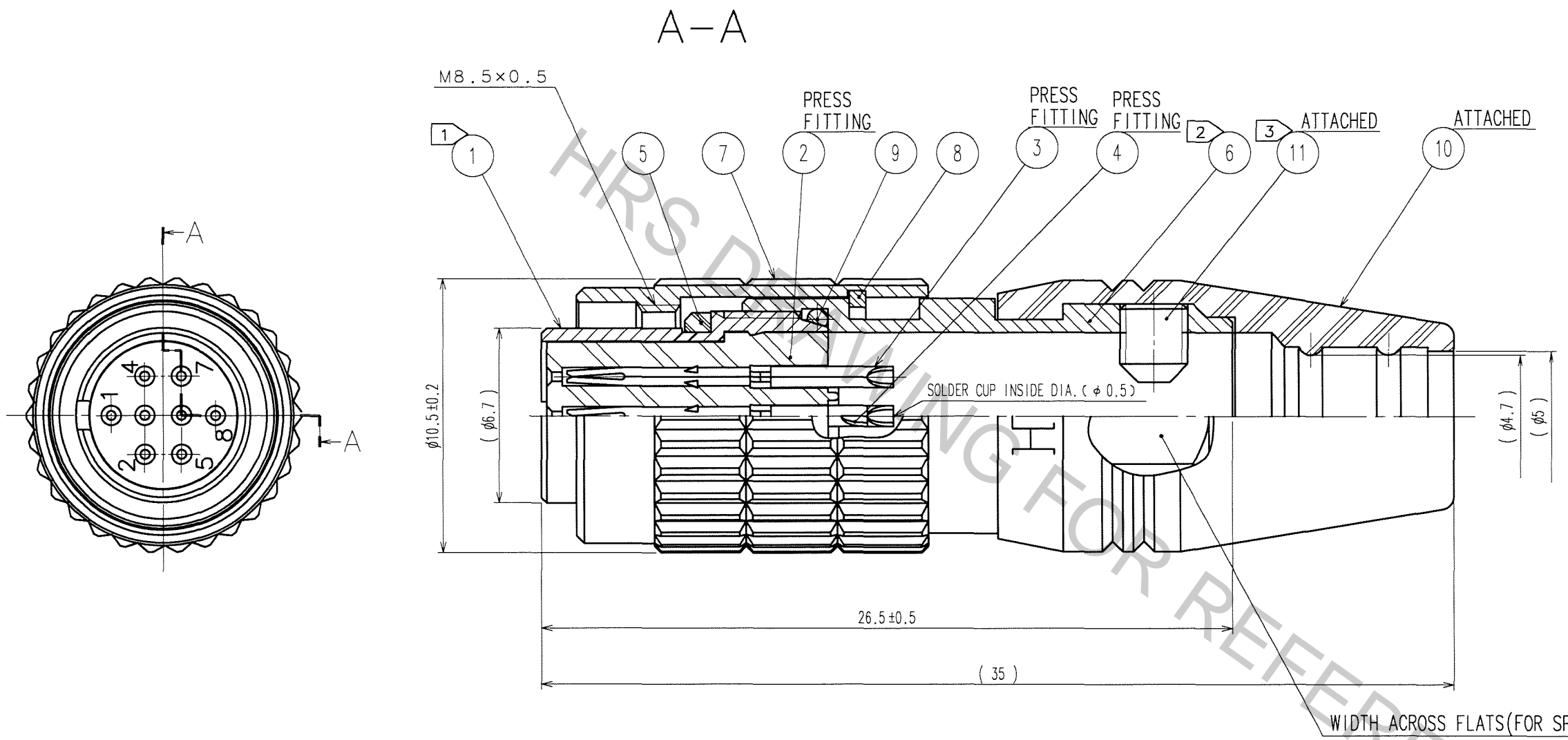

- NOTES
- ① THREAD PORTION OF REF.NO. ① IS APPLIED WITH PRECOATING TO PREVENT LOOSENESS. HOWEVER, THE ADHESIVE EFFECTIVENESS IS DECREASED WHEN REUSED. THEREFORE, TREAD PORTION IS RECOMMENDED TO COAT WITH LOCTITE 271 MANUFACTURED BY HENKEL JAPAN OR EQUIVALENT.
 - ② THE RECOMMENDED CLAMP TORQUE OF REF NO. ⑥ TO BE 1 N · m.
 - ③ THE TIP OF REF.NO. ⑪ SHALL BE FIXED TO THE CONCAVE PORTION WITH REF.NO. ⑫ CLAMPED TO THE CABLE. OPPOSITE SIDE DIMENSION OF A HEXAGON SOCKET OF REF.NO. ⑪ IS 1.27mm. AND THE RECOMMENDED TIGHTENING TORQUE OF REF.NO. ⑪ TO BE 0.3 TO 0.4 N · m.
 - ④ MANUAL CRIMPING TOOL OF REF.NO. ⑫ : HR10A-TC-02(CL150-0041-2) (THE HOLE DIAMETER FOR CRIMPING : φ 5.3)
 - ⑤ ROTATION EXAMPLES OF REF.NO. ① AND ⑥ ARE SHOWN.
 - ⑥ SURFACE PLATING: GOLD 0.2μ m min. TERMINAL PLATING: GOLD FLASH. UNDER PLATING: NICKEL 2μ m min.
 - ⑦ THE CABLE PULL AND TWISTING STRENGTH AND OTHER CHARACTERISTICS MAY DIFFER, DEPENDING ON THE CABLE STRUCTURE. PLEASE CONFIRM BEFORE THE USE.

6	BRASS	NICKEL PLATING	12	BRASS	
5	ETHYLENE PROPYLENE RUBBER	(BLACK)	11	STEEL	NICKLE PLATING M2.6×0.45×3
4	PHOSPHOR BRONZE	⑥	10	ETHYLENE PROPYLENE RUBBER	(BLACK)
3	PHOSPHOR BRONZE	⑥	9	ETHYLENE PROPYLENE RUBBER	(BLACK)
2	POLYPHENYLENE SULFIDE	(BLACK) UL94V-0	8	PHOSPHOR BRONZE	NICKEL PLATING
1	ZINC ALLOY	MATTE FINISH NICKEL PLATED	7	BRASS	NICKEL PLATING
NO.	MATERIAL	FINISH, REMARKS	NO.	MATERIAL	FINISH, REMARKS

CODE NO.(OLD) CL		DRAWN <i>M.Sato</i> 07.03.22	DESIGNED <i>H.Kawashima</i> 07.3.22	CHECKED <i>E.Kurita</i> 07.03.22	APPROVED <i>M.Sato</i> 07.03.22	RELEASED
DRAWING NO. EDC3-047752-72		PART NO. HR25-7TP-8S(72)		CODE NO. CL125-0006-1-72		
SCALE 5 : 1		UNITS mm		HRS HIROSE ELECTRIC CO., LTD		

TO
R