

COUNT	DESCRIPTION OF REVISIONS	BY	CHKD	DATE	COUNT	DESCRIPTION OF REVISIONS	BY	CHKD	DATE
△				..	△				..
△				..	△				..
△				..	△				..

B-B(20:1)

A-A(20:1)

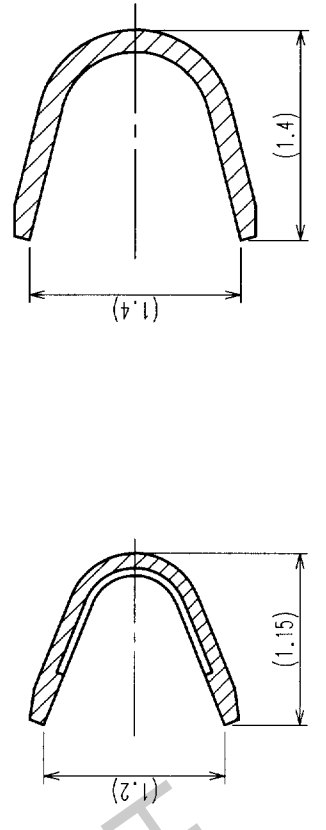
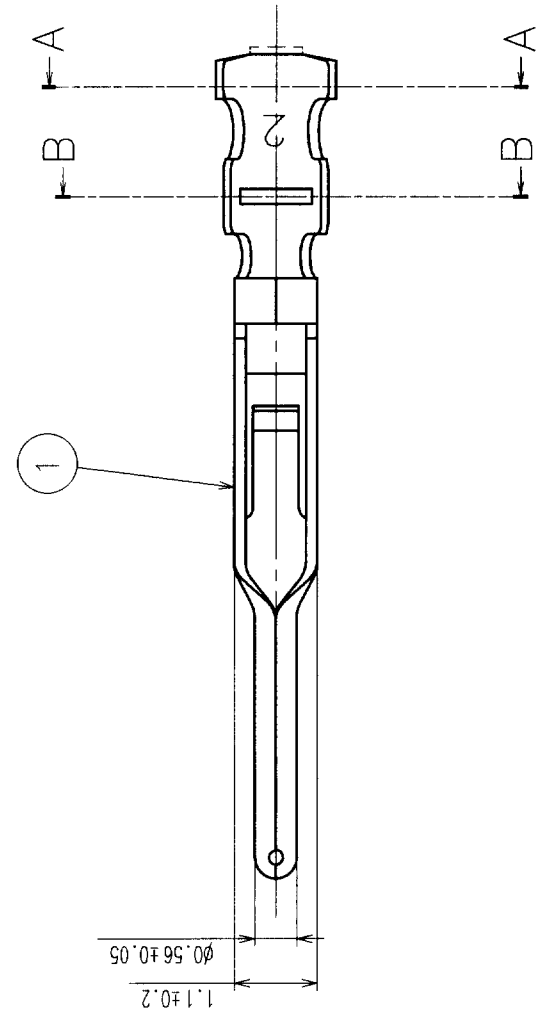

3 FIG.1 RECOMMENDED CABLE PREPARATION DIMENSIONS

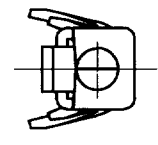
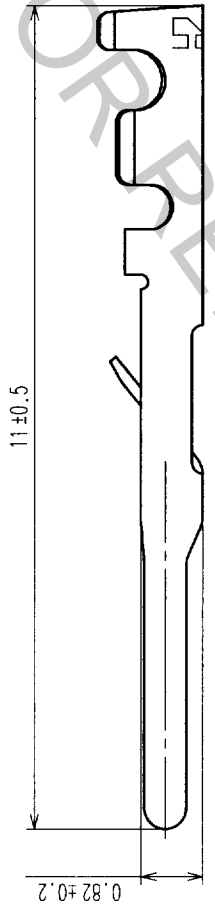
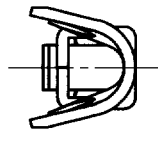
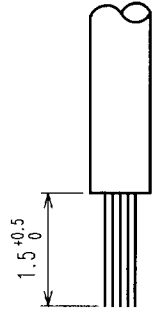

- NOTES
- 1 THIS PRODUCT IS APPLY TO THE WIRE 26-30 AWG(WIRE JACKET DIAMETER ϕ 1 MAX).
 - 2 APPLICABLE OPERATION CRIMP TOOL:HT102/HR30-1
 - 3 RECOMMENDED CABLE PREPARATION DIMENSIONS ARE SHOWN IN FIG.1.
 - 4 PER PACK:100 CONTACTS

NO.	PHOSPHOR BRONZE MATERIAL	SELECTIVE GOLD PLATING FINISH, REMARKS	NO.	MATERIAL	FINISH, REMARKS	FINISH, REMARKS	
1							
CODE NO. (OLD)		DRAWN		DESIGNED	CHECKED	APPROVED	RELEASED
		H.Zemba		H.Zemba	E. Kumi	M. Yoshida	
		01.01.05		01.01.05	01.01.05	01.01.10	
DRAWING NO.		PART NO.					
EDC3-112589		HR30-PC-111					
SCALE		CODE NO.					
10 : 1		CL130-0022-3					
UNITS		HIROSE ELECTRIC CO., LTD					
mm							

TO	
R	