

Aug.1.2016 Copyright 2016 HIROSE ELECTRIC CO., LTD. All Rights Reserved.

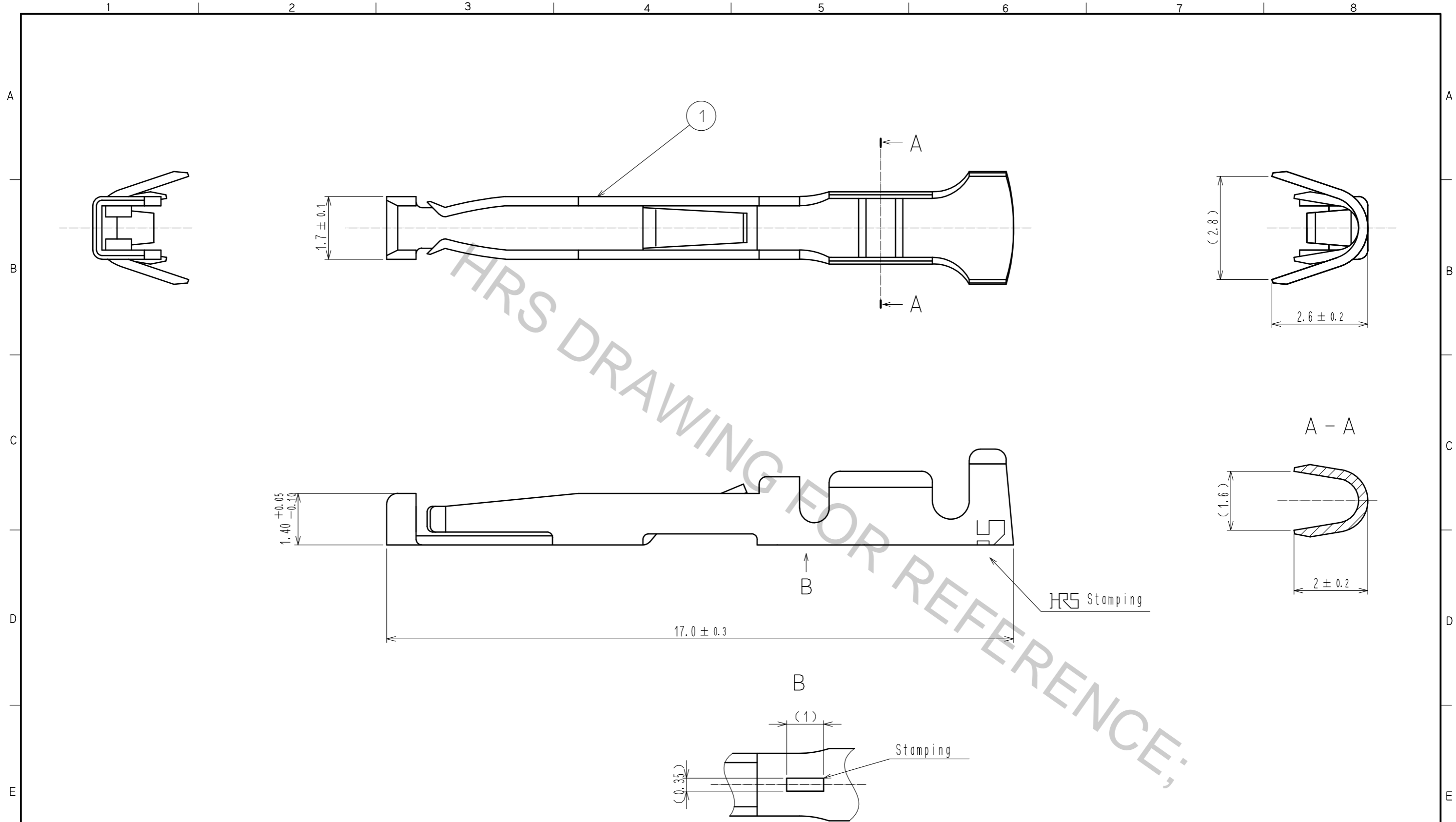

- Notes
- ① Applicable hand crimping tool : HT802/RM-11(CLCL150-0401-6-00)
 - ② Applicable crimp contact extraction tool : RM-TP(CL150-0008-7-00)
 - ③ Applicable wire ID marking : AWG#24~20
 - ④ A package containing 100 pieces.

| | | | | | | | | |
|--------------------------------------|-----------------|------------------------|------------|--|------------------|-----------------------|--------------------------|--------------------|
| 1 | Shosphor bronze | Silver plating | | | | | | |
| NO. | MATERIAL | FINISH . REMARKS | NO. | MATERIAL | FINISH . REMARKS | | | |
| UNITS mm | | SCALE 10: 1 | COUNT 1 | DESCRIPTION OF REVISIONS DIS-C-00000833 | | DESIGNED HK. NAMAI | CHECKED HY. KOBAYASHI | DATE 16. 02. 29 |
| HRS HIROSE ELECTRIC CO., LTD. | | APPROVED : MR. YOSHIDA | 05. 01. 05 | DRAWING NO. EDC3-007612-00 | | | | |
| | | CHECKED : MO. SATOH | 05. 01. 05 | PART NO. RM-SC-112 | | | | |
| | | DESIGNED : YH. YAMADA | 05. 01. 05 | CODE NO. CL109-0669-0-00 | | | | |
| | | DRAWN : YH. YAMADA | 05. 01. 05 | | | | | |