

Aug.1.2016 Copyright 2016 HIROSE ELECTRIC CO., LTD. All Rights Reserved.

Fig - 1 PACKING SPECIFICATION -In the case of 4000 pcs-

1. STORED IN A TRAY (200pcs / tray)

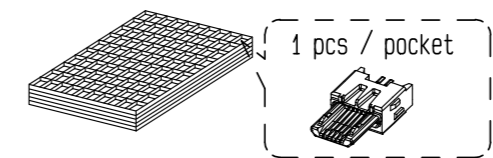

2. BANDED FOR A PACK

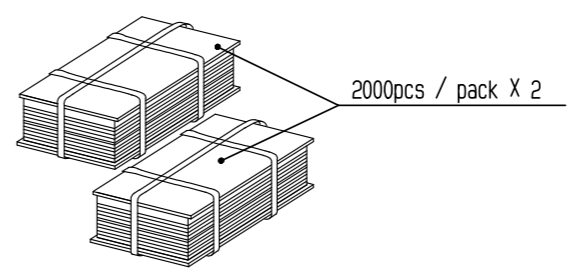

3. STORED IN A CARTON BOX

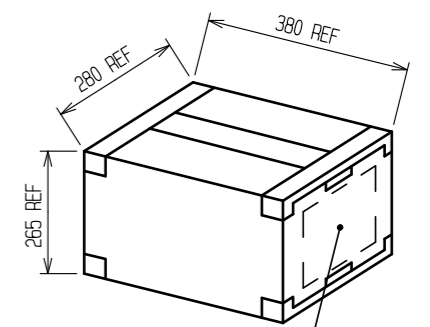

SHOWN AS FOLLOWS:  
 - Part No.  
 - Code No.  
 - QTY  
 - Lot No.

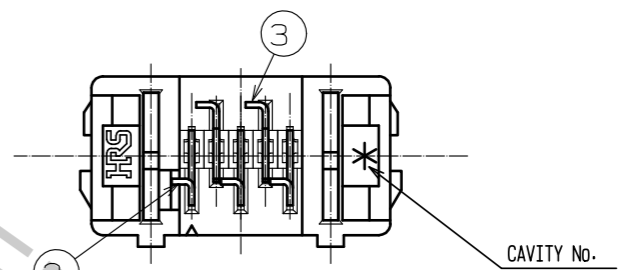
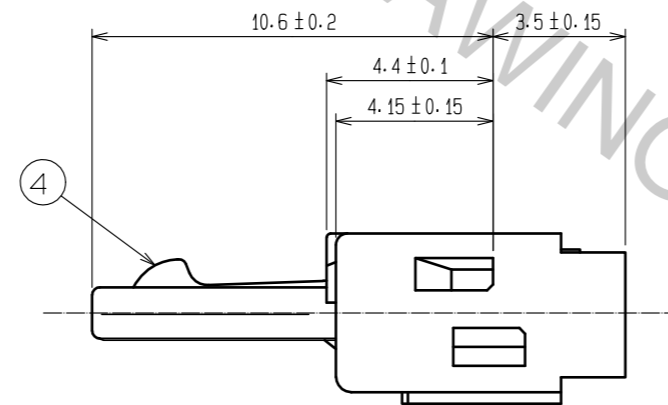
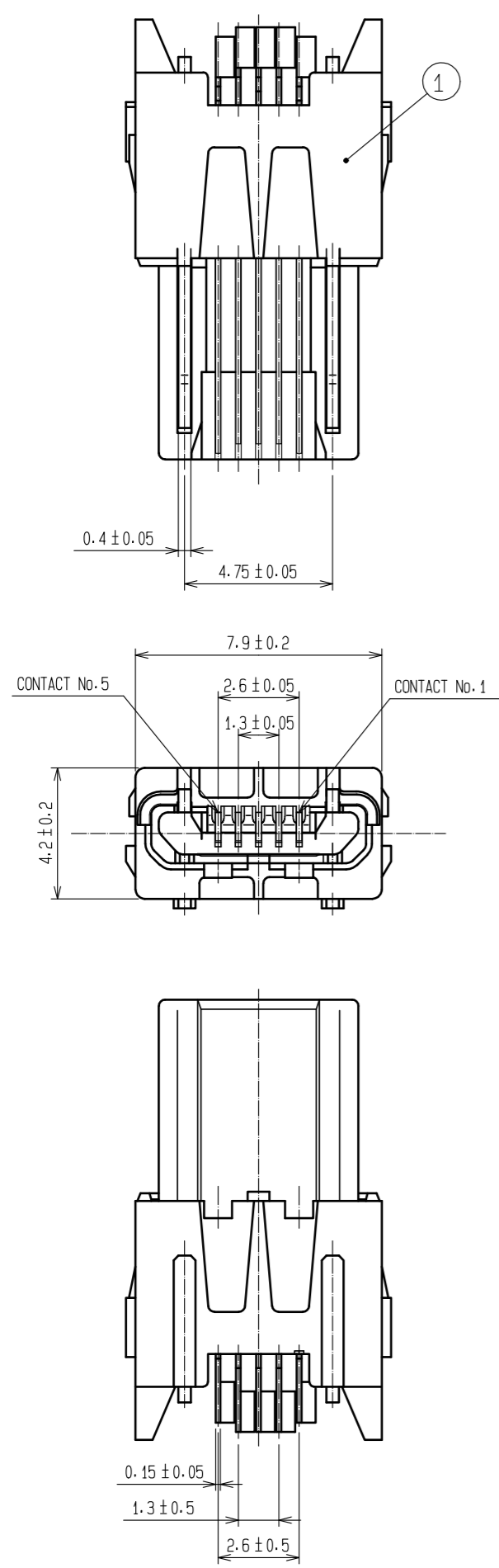

NOTES 1 This is wire soldering type.  
 Please refer to the assembly manual, ETAD-E2699, for detail.

2 Plating  
 - under plating Nickel 2 μm min.  
 - contact area Gold 0.75 μm min.  
 - lead area Tin 1 μm min.

2	COPPER ALLOY	2	4	STAINLESS STEEL				
1	LCP-M	BLACK UL94V-0	3	COPPER ALLOY				
NO.	MATERIAL	FINISH . REMARKS	NO.	MATERIAL	FINISH . REMARKS			
UNITS	mm	SCALE	5 : 1	COUNT	DESCRIPTION OF REVISIONS	DESIGNED	CHECKED	DATE
APPROVED : NM. NISHIMATSU		15.10.27		DRAWING NO.		EDC-125857-31-00		
CHECKED : KN. ICHIKAWA		15.10.27		PART NO.		ZX40-B-5S-UNIT(31)		
DESIGNED : TS. ITO		15.10.27		CODE NO.		CL242-0002-4-31		
DRAWN : AK. AKIYAMA		15.10.27						

Aug.1.2016 Copyright 2016 HIROSE ELECTRIC CO., LTD. All Rights Reserved.

Fig - 2 SHIELDING-PLATE ASSEMBLY

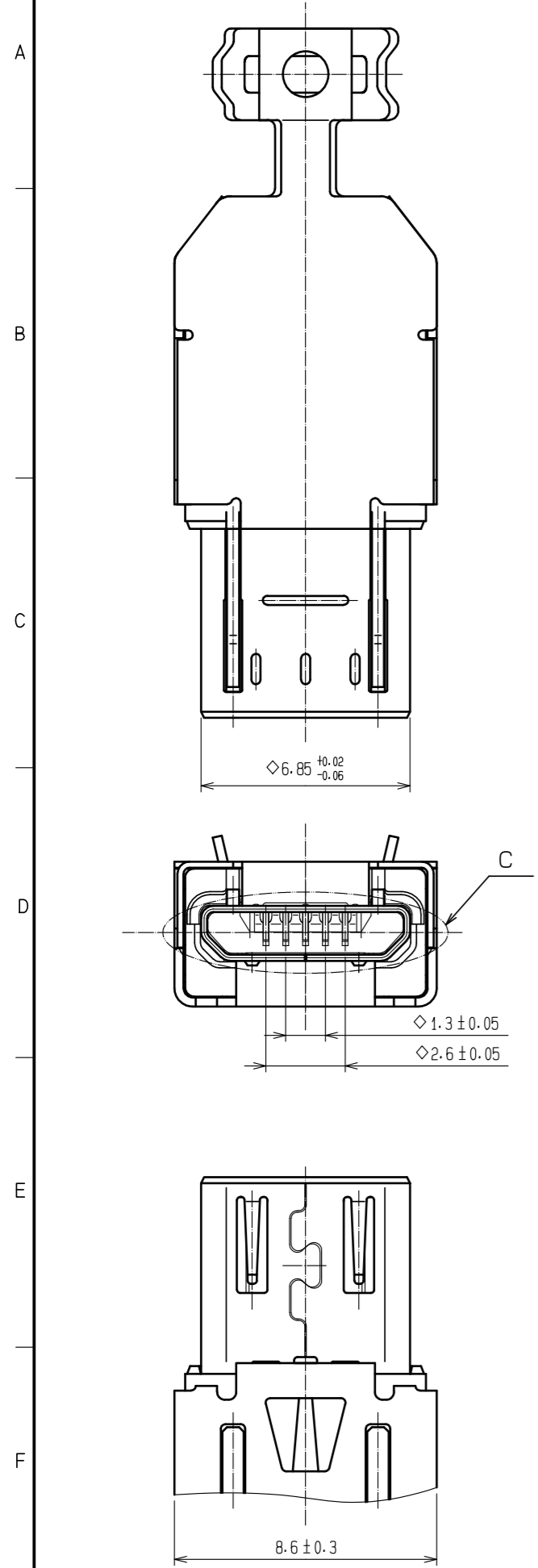
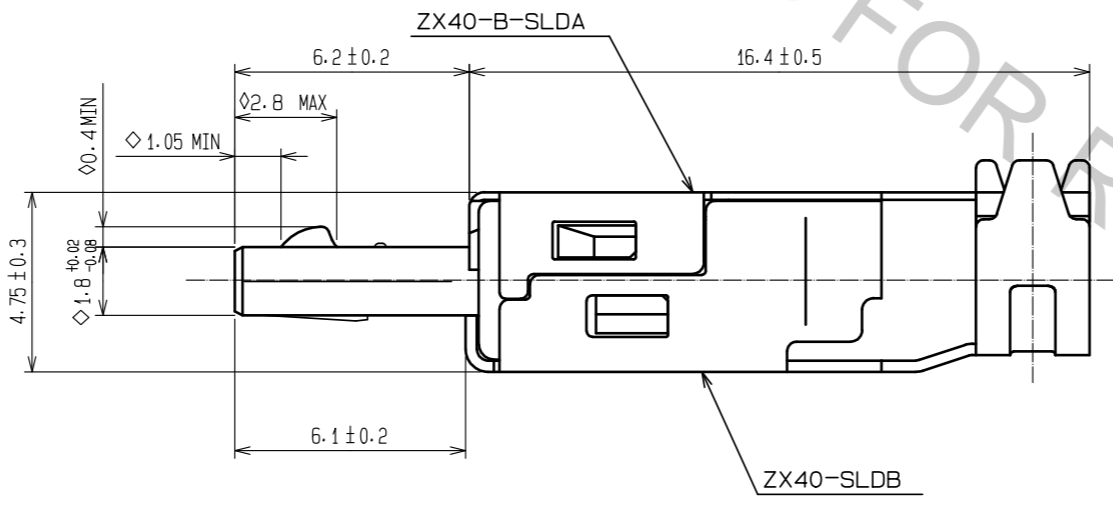
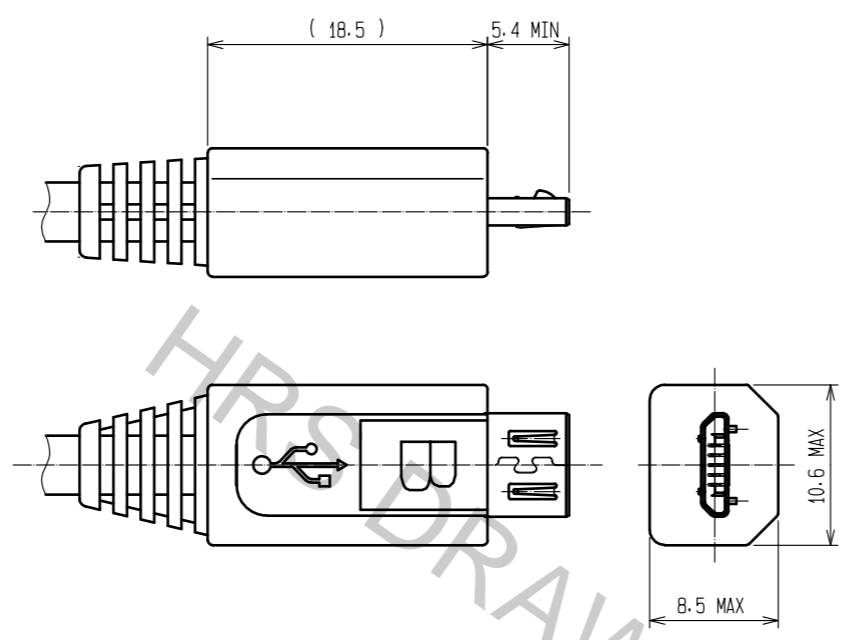

Fig - 3 OVER-MOLDING

(Refer to USB specification)



ZX40-B-SLDA

Code No. CL242-0003-7

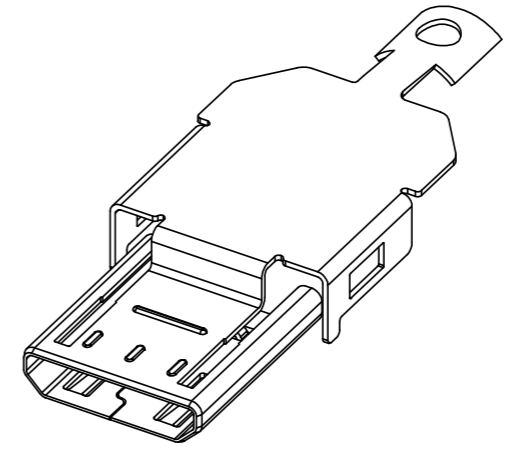

Note:  
- Sold separately  
- Delivered by the reel

ZX40-SLDB

Code No. CL242-0004-0

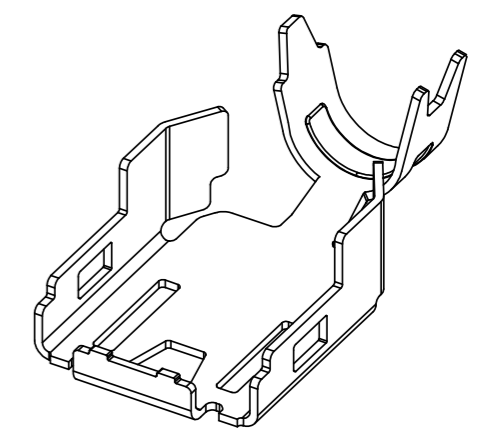

Note:  
- Sold separately  
- Delivered by the reel  
- Applied to  $\phi 3.8 \text{ mm}$  cable

Fig - 4 MATED CONDITION

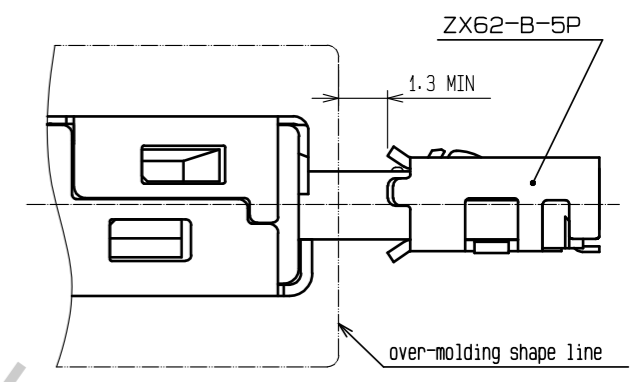

NOTES 3 Shielding-plates, ZX40-B-SLDA and ZX40-SLDB, are used for assembly.  
4 \* $\diamond$ \*symbol added to each dimension means critical dimension on USB specification. Please check them after over-molding.

<b>HRS</b>	DRAWING NO.	EDC-125857-31-00	
	PART NO.	ZX40-B-5S-UNIT(31)	
	CODE NO.	CL242-0002-4-31	