

THIS DOCUMENT IS THE PROPERTY OF KEYSTONE ELECTRONICS CORP. AND SHALL NOT BE REPRODUCED, DISTRIBUTED OR USED AS A BASIS FOR MANUFACTURE WITHOUT PRIOR WRITTEN PERMISSION FROM KEYSTONE ELECTRONICS CORP.

REQUIRED SPACING FOR 'AAA' CLIP

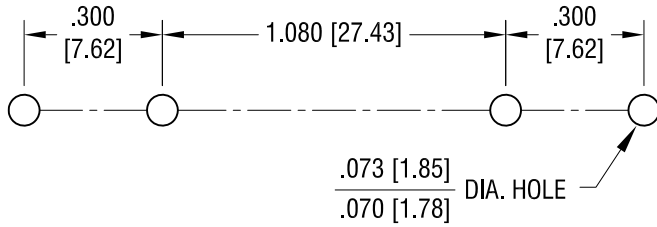

ACTUAL SIZE

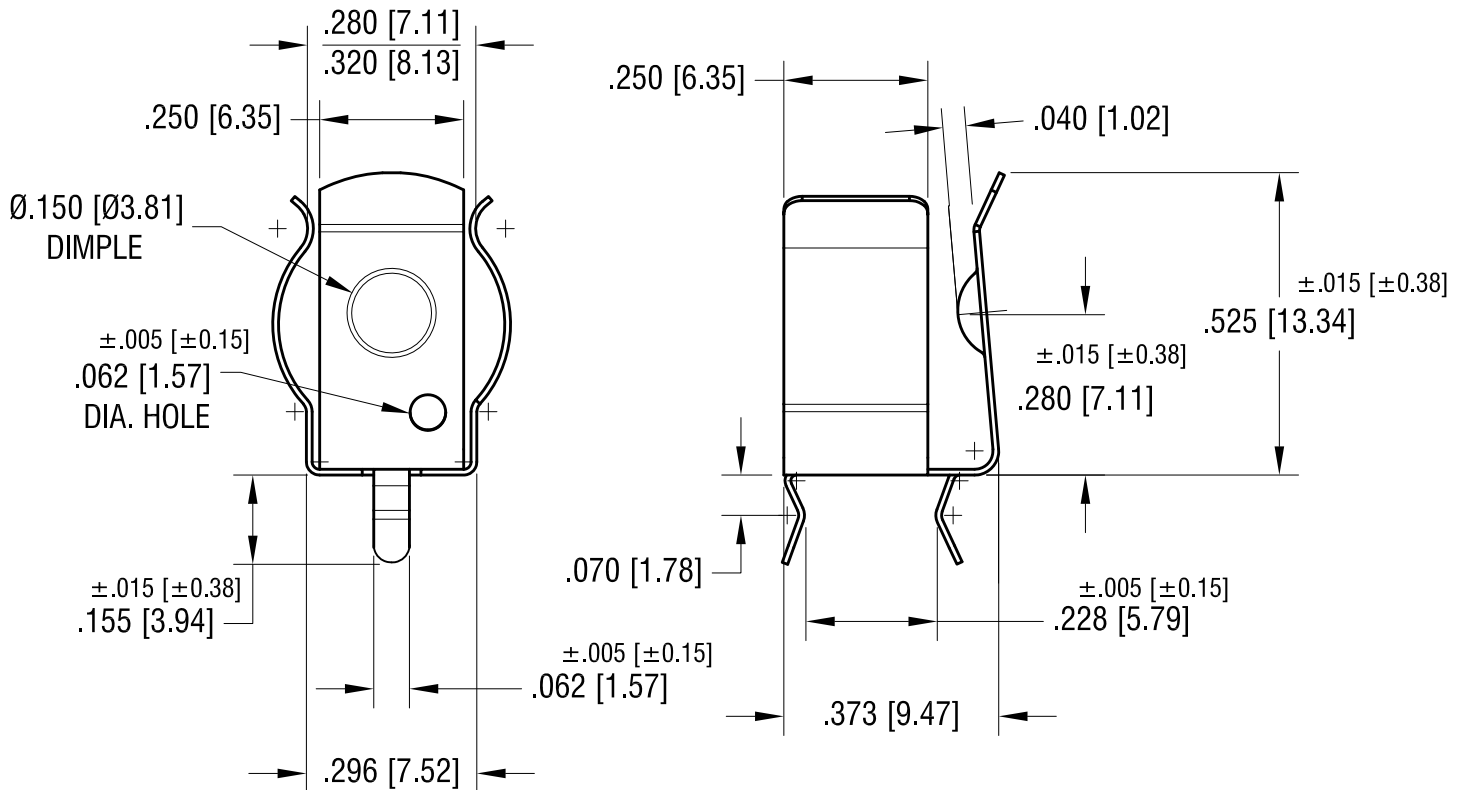
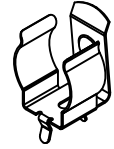

NOTE:

1. HEAT TREAT TO SPRING TEMPER.

**KEYSTONE ELECTRONICS CORP.**

www.keyelco.com • ASTORIA, N.Y. 11105-2017 • Tel (718) 956-8900

10.05.15	CHANGE AS PER ECN15-112	P
7.17.14	CHANGE AS PER ECN14-069	N
6.28.13	CHANGE AS PER ECN 13-053	M
3.7.05	CHANGE AS PER ECN 05-015	L
DATE	DESCRIPTION	REV.

PART NAME				'AAA'-'N' PC BATTERY CLIP			
MATERIAL				.010 [.25] TH'K ANNEALED SPRING STEEL			
FINISH				DRN BY		DATE	
TIN NICKEL PLATE				BOONE		2.3.98	
				APP'D		SCALE	
				LN		3X	
TOLERANCES				INCH		[MM]	
DECIMAL				± .010		[± 0.25]	
ANGULAR				± 1°			
UNLESS OTHERWISE SPECIFIED				CODE		DWG NO.	
				C		82	