

THIS COPY IS PROVIDED ON A RESTRICTED BASIS AND IS NOT TO BE USED IN ANY WAY DETRIMENTAL TO THE INTERESTS OF PANDUIT CORP.

PANDUIT TOOL NO.	INSTALLS * THE FOLLOWING CABLE TIE CROSS-SECTIONS **	WEIGHT/PC	
		OZ	GRAMS
GTSL	SM,M,I,S	8.8	249

NOTES, UNLESS OTHERWISE SPECIFIED:

* THIS TOOL TIGHTENS CABLE TIES AND CUTS OFF EXCESS PORTION WHEN PRESET TENSION IS ATTAINED.

** CABLE TIE CROSS-SECTION CODE:
SM=SUBMINIATURE, M= MINIATURE
I= INTERMEDIATE, S= STANDARD.

SPECIFICATIONS SHOWN IN PARENTHESIS ARE METRIC.

REFERENCE:

KGTSBLD: REPLACEMENT BLADE KIT.
KGTSTL: TENSION LOCKING KIT.
WB27359D01: BLADE GUARD FOR *Contour-TY*

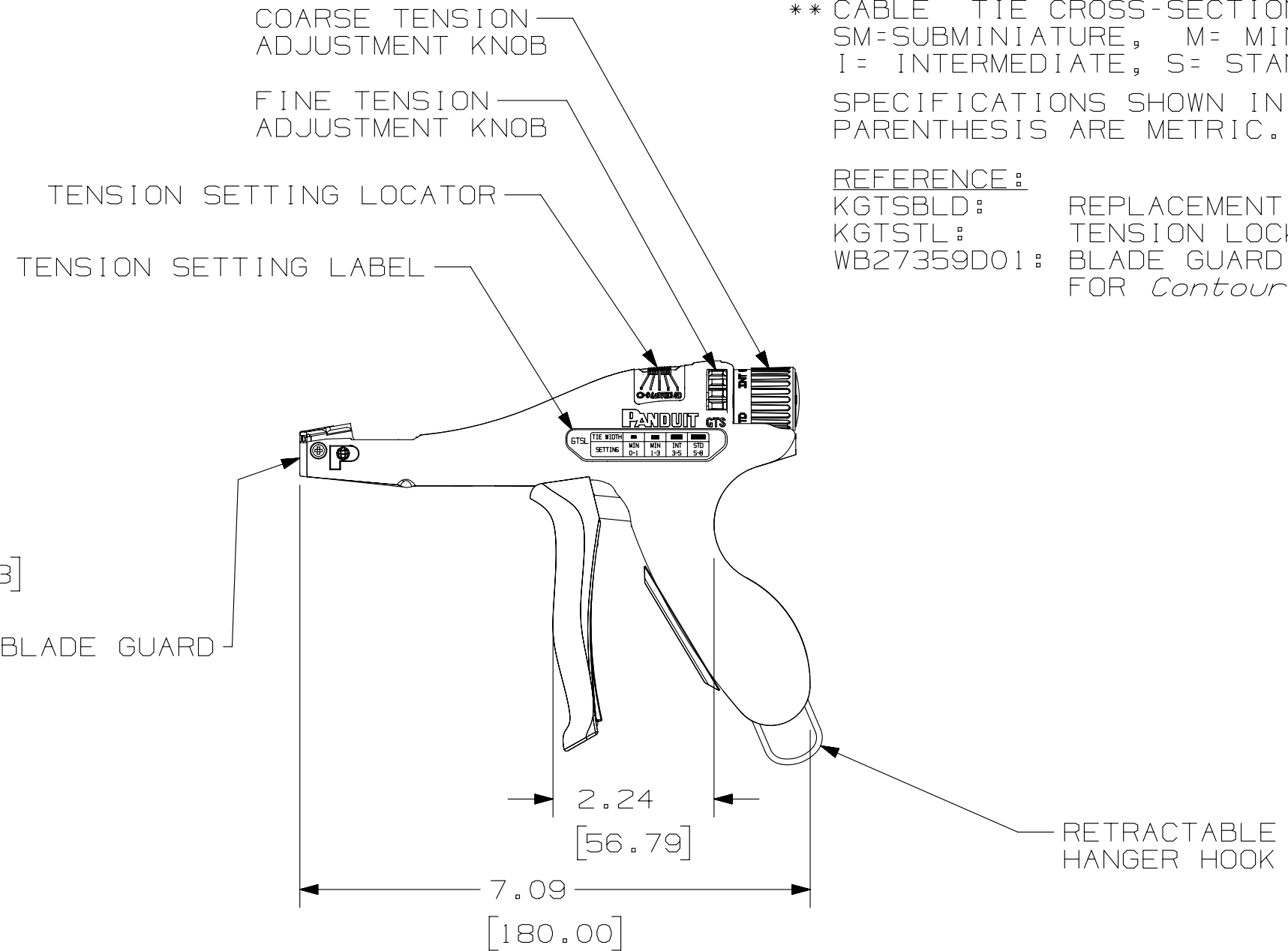
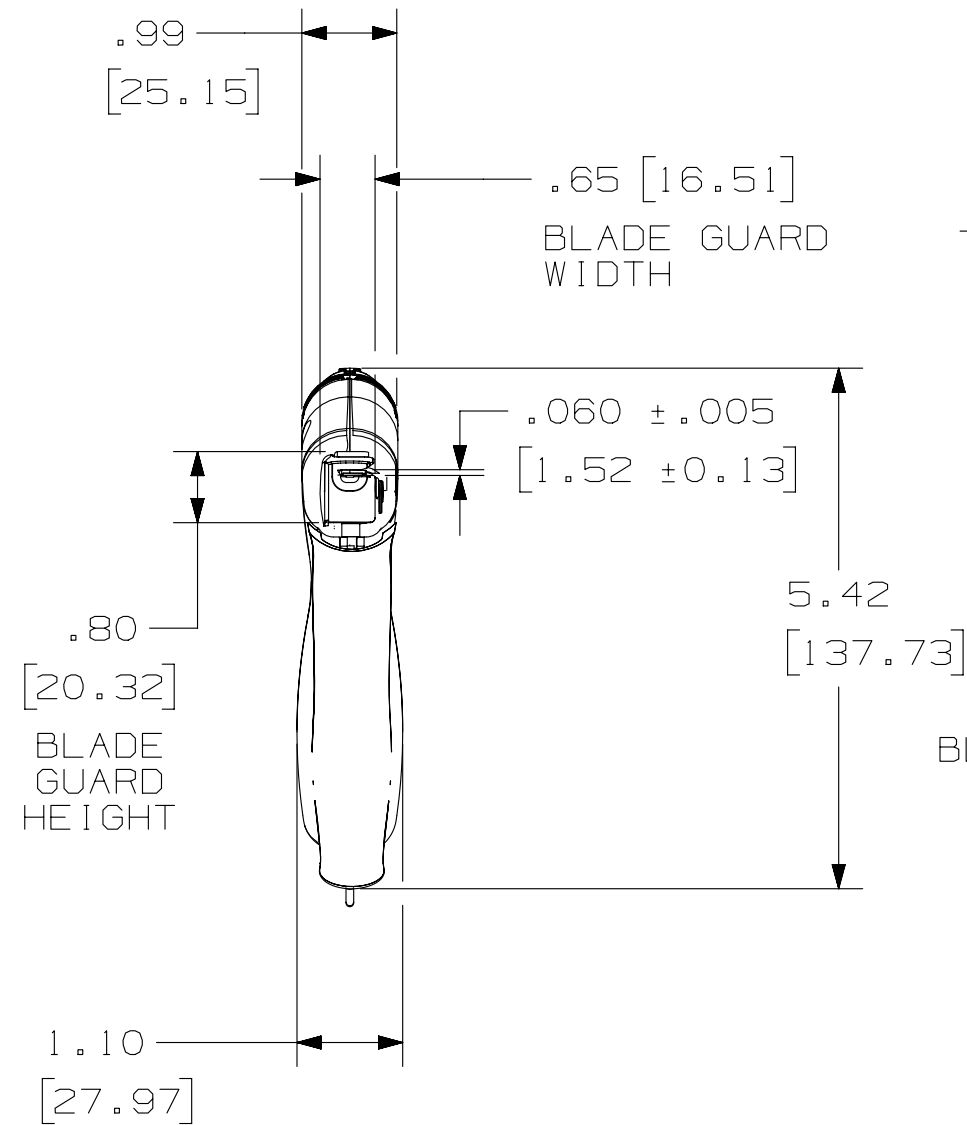

CAD FILENAME/LAYERS R24915BA_DS_WB24915B01_01A

PANDUIT CORP TINLEY PARK, ILLINOIS
CD, GTSL

UNLESS OTHERWISE SPECIFIED,
DIMENSIONAL TOLERANCES ARE:
(.X) ± -- (,XXX) ± --
(.XX) ± -- ANGLES ± --

UNLESS OTHERWISE SPECIFIED,
ALL DIMENSIONS ARE GIVEN IN
INCHES, THIRD ANGLE PROJECTION

DRAWN BY DCS

MAT'L:

SCALE 1/2 = 1

DATE 08-26-04

CHK'D MBR

DRAWING NO. WB24915B01
DWG SIZE B

REV	DATE	BY	CHK	DESCRIPTION	ECN	R	CUST	SUP
01	1-6-15	JEH	ABJ	CORRECTED AND RELEASED	4781	--		ABJ