

DRAWING No.
152023

SHT. 1
OF
1 SHTS.

© THE COPYRIGHT OF THIS DRAWING IS RESERVED BY HELLERMANN TYTON. IT IS ISSUED ON CONDITION THAT IT IS NOT COPIED, REPRODUCED OR DISCLOSED TO A THIRD PARTY EITHER WHOLLY OR IN PART WITHOUT THE CONSENT IN WRITING OF HELLERMANN TYTON.

THIRD ANGLE PROJECTION

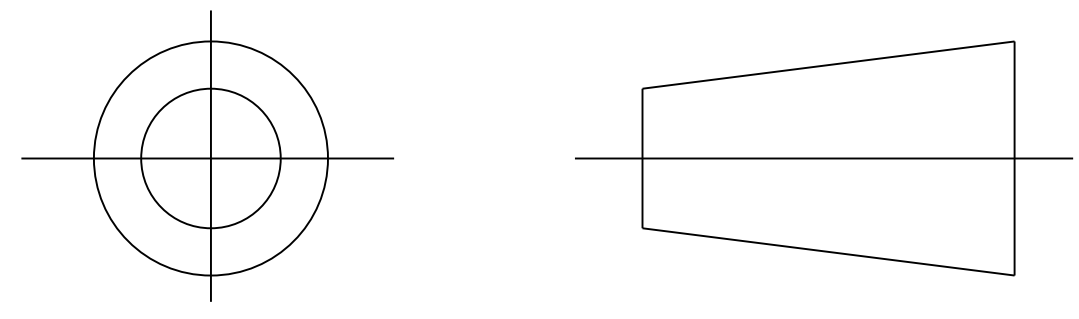

BS 8888

DO NOT SCALE
IF IN DOUBT ASK

Q.A.	H/S SETT	
H/S Q.A.	REL. INSP.	
H/S PROD	EXT. ISS. CODE	5/12

STANDARD PART (AFTER UNRESTRICTED RECOVERY)

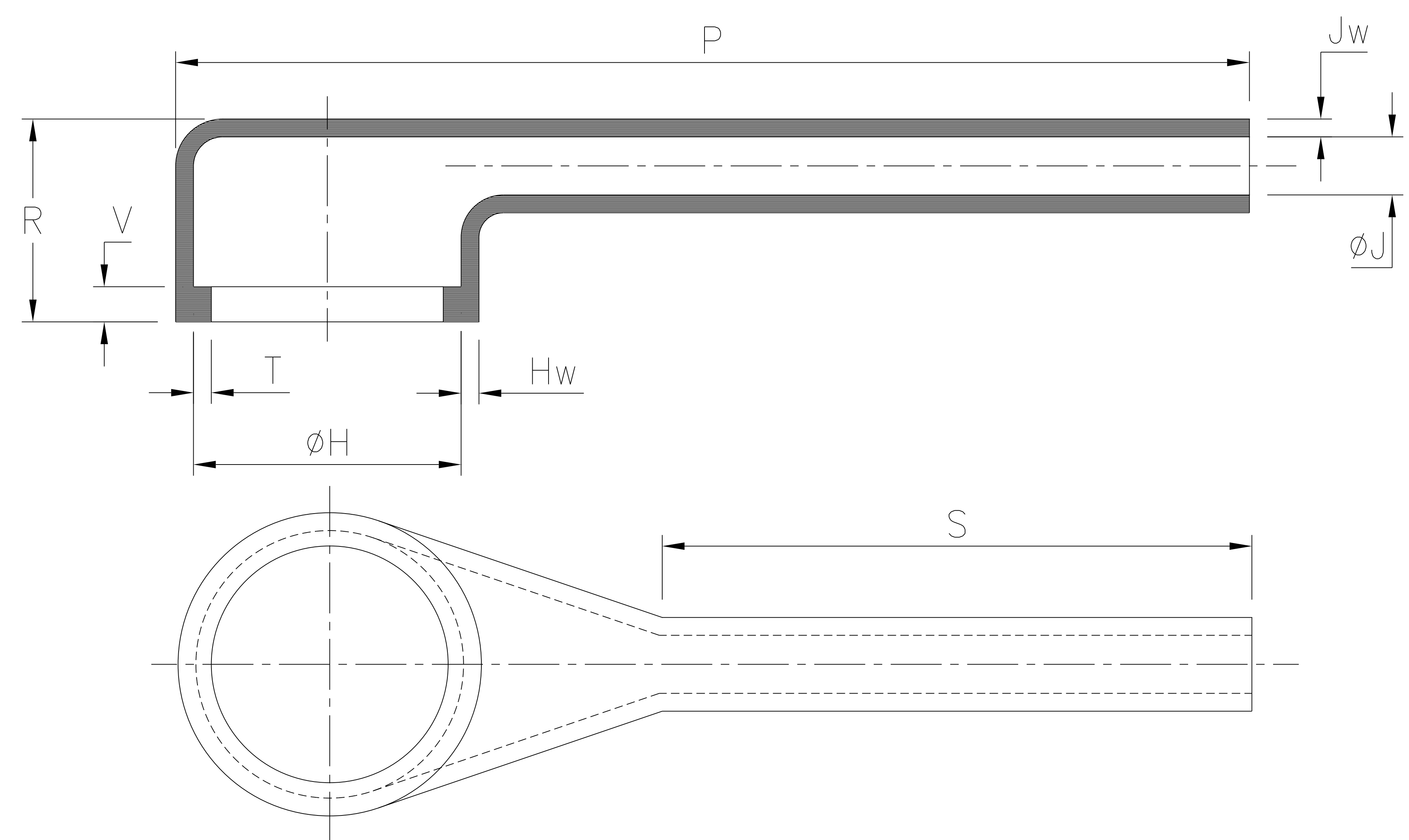

EXPANDED (AS SUPPLIED)

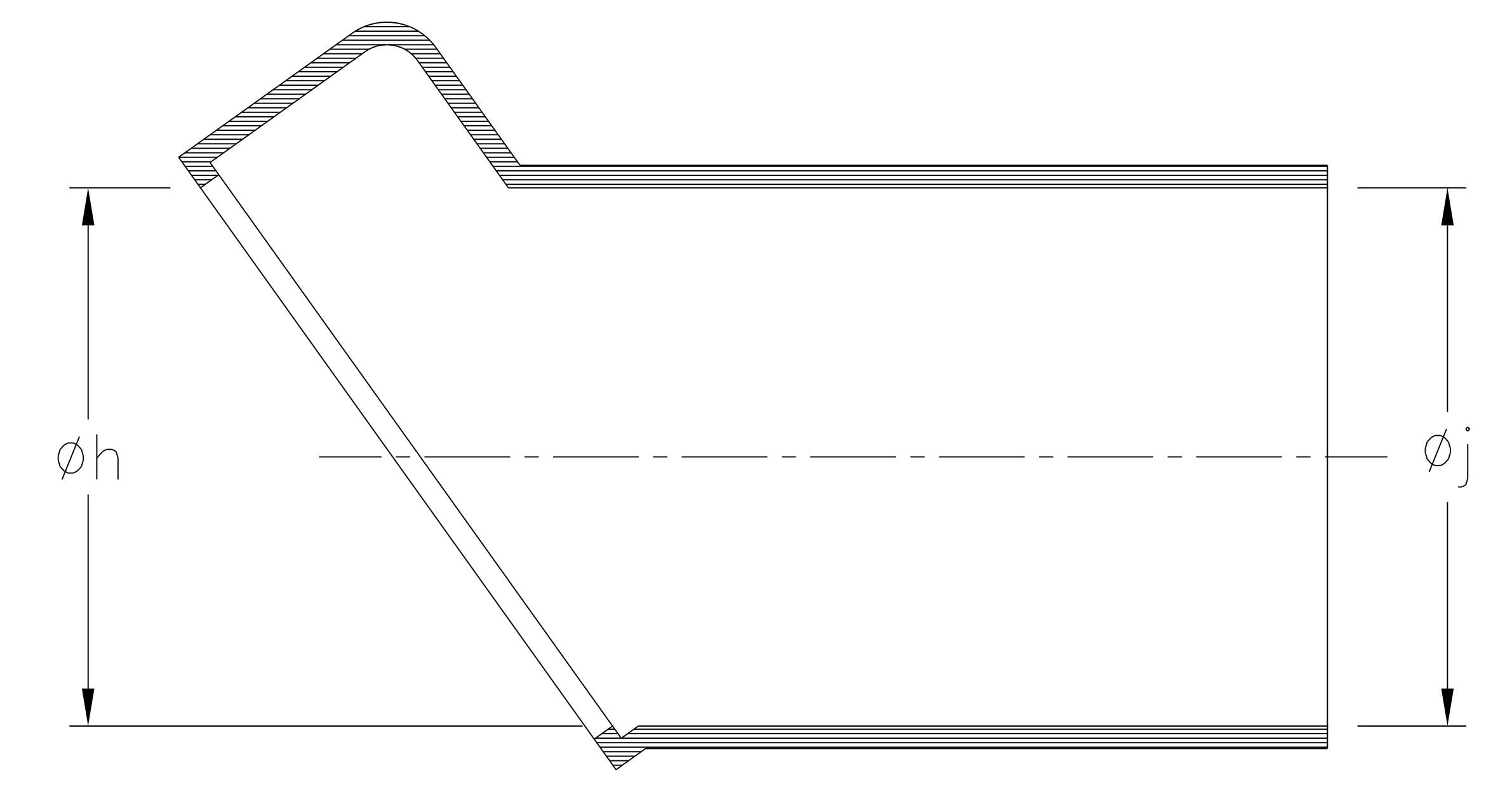

OPTIONS TO STANDARD PART

FILLER PORT/DRAIN HOLES (CODES P, D AND P1)

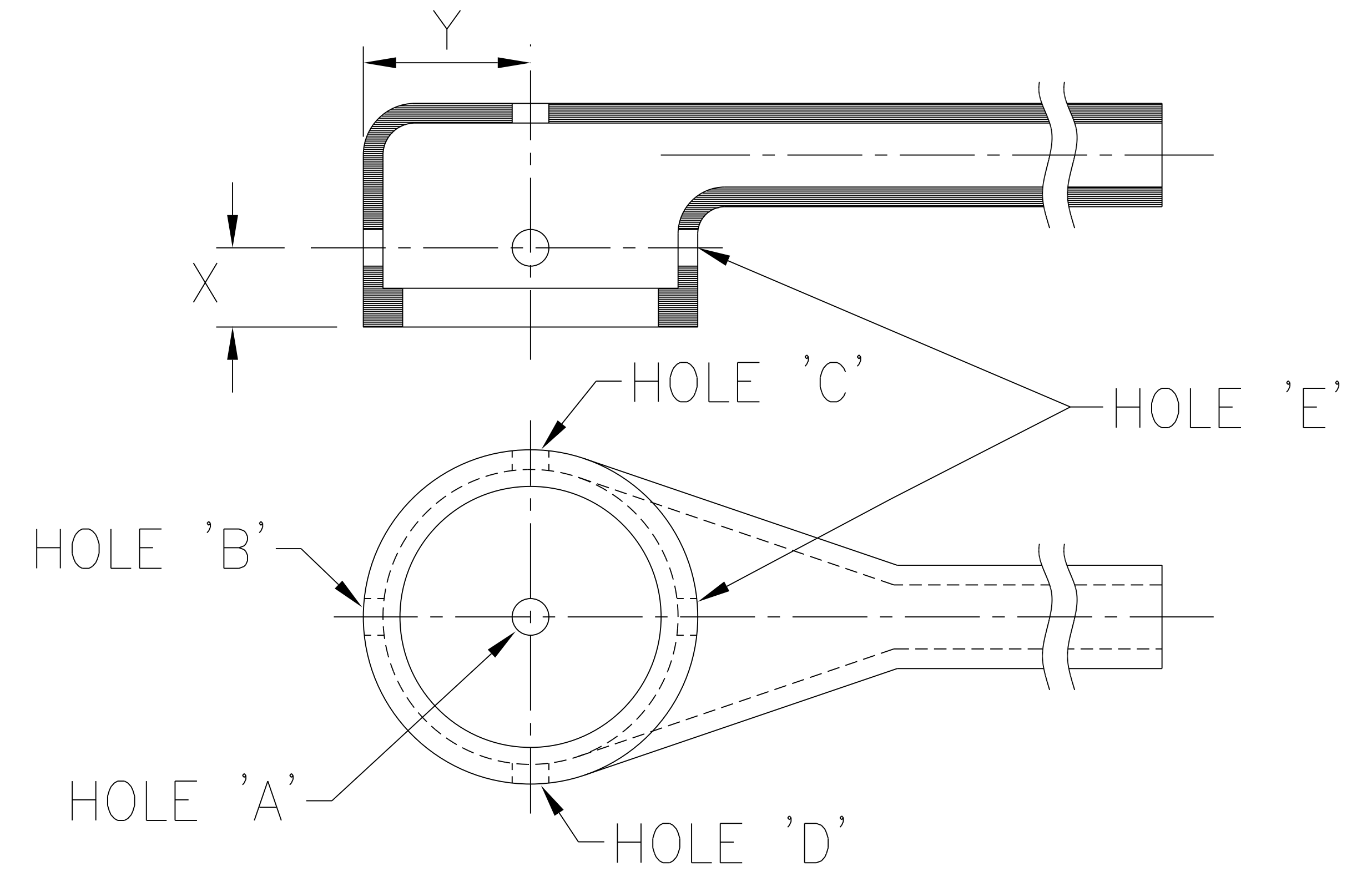

SPEC.	PART NO.	EXPANDED DIAMETERS (AS SUPPLIED)		RECOVERED DIAMETERS		RECOVERED DIMENSIONS						
		Øh	Øj	ØH	ØJ	P	R	S	T	V	Hw	Jw
		MIN	MIN	MAX	MAX	±10%	±10%	NOM	±20%	MAX	±20%	±30%
VG 95343 T06F001A	1121-1	22 (.87)	22 (.87)	12 (.47)	6.5 (.26)	70 (2.76)	19 (.75)	52 (2.05)	1.0 (.04)	3.3 (.13)	1.5 (.06)	1.1 (.04)
Mil Spec	1121-4	22.3 (.88)	22.3 (.88)	11.4 (.45)	6.5 (.26)	105.2 (4.14)	18.5 (.73)	87.2 (3.43)	1.0 (.04)	3.3 (.13)	1.5 (.06)	1.1 (.04)

OPTIONAL FILLER PORT/DRAIN HOLES DETAIL			
SPEC.	PART NO.	RECOVERED DIMENSIONS	
		X	Y
		±20%	±20%
VG 95343 T07F001A	1121-1	14 (.55)	7 (.28)
Mil Spec	1121-4	11.9 (.47)	7 (.28)

CODE & TYPE		RECOVERED HOLE DETAILS
P	FILLER PORT	HOLES 'A' & 'B' ONLY 'A' Ø3mm NOM (.12) 'B' Ø4.5mm NOM (.18)
D	DRAIN HOLES	4 HOLES 'A', 'B', 'C' and 'D' ALL 4 HOLES Ø3mm NOM (.12)
P1	FILLER PORT (ALT)	HOLE 'B' ONLY 'B' Ø4.5mm NOM (.18)
D5	DRAIN HOLES	5 HOLES 'A', 'B', 'C', 'D' and 'E' ALL 5 HOLES Ø3mm NOM (.12)

5	P1526	DC	13/11/15
4	P1426	GB	28/08/13
3	P1393	CM	03/09/12
2	P1344	CM	03/10/11
1	P1184	S.Almond	20/03/08
ISSUE	NOTE No.	DRAWN	DATE

HellermannTyton
William Prance Road,
Plymouth International Med. & Tech. Park,
Plymouth, PL6 5WR
Tel ++44 (0) 1752 701261
Fax ++44 (0) 1752 790058

NAME	S.Almond	SCALE	NTS	ADHESIVE	A3 ORIGINAL SHEET SIZE 420mm x 297mm	SHT. 1 OF 1 SHTS.
DATE	20/03/08	DIMS IN	mm (in)			
TITLE	RT. ANGLE SLEEVE			PART No.	DRAWING No.	
				1121	152023	