

DRAWING No.  
152087

SHT. 1  
OF  
1 SHTS.

© THE COPYRIGHT OF THIS DRAWING IS RESERVED BY HELLERMANN TYTON. IT IS ISSUED ON CONDITION THAT IT IS NOT COPIED, REPRODUCED OR DISCLOSED TO A THIRD PARTY EITHER WHOLLY OR IN PART WITHOUT THE CONSENT IN WRITING OF HELLERMANN TYTON.

THIRD ANGLE PROJECTION

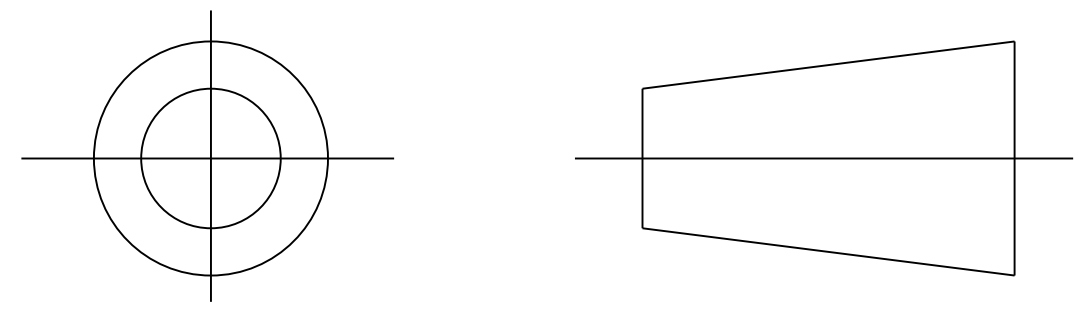

BS 8888

DO NOT SCALE  
IF IN DOUBT ASK

Q.A.	H/S SETT
H/S Q.A.	REL. INSP.
H/S PROD	EXT. ISS. CODE

STANDARD PART (AFTER UNRESTRICTED RECOVERY)

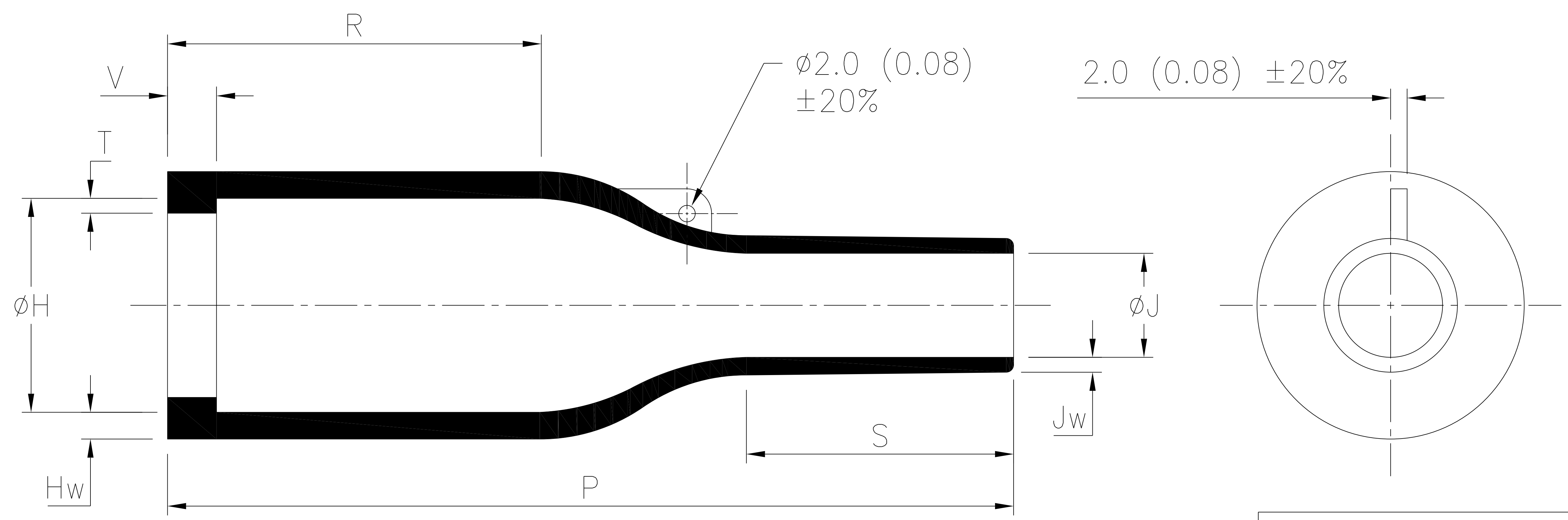

EXPANDED (AS SUPPLIED)

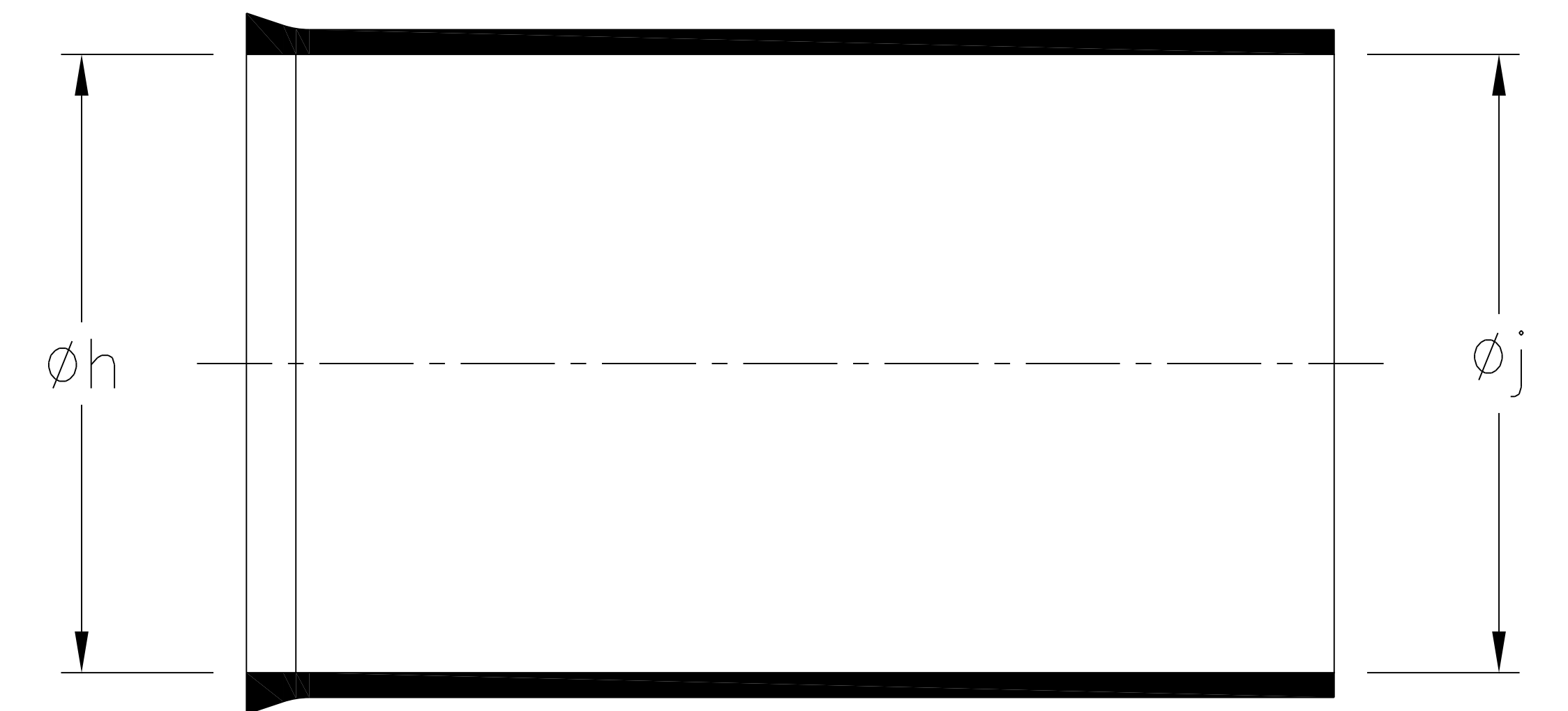

DRAWING OFFICE TO NOTIFY DATABASE ADMINISTRATOR TO UPDATE PART NUMBER IF DRAWING IS UP ISSUED.

OPTIONAL FILLER PORT DETAIL

SPEC.	PART No.	RECOVERED DIMENSIONS	
		X	Y
		$\pm 20\%$	$\pm 20\%$
VG 95343 T07A005A	156-41	12 (0.47)	30 (1.18)
VG 95343 T07B005A	156-42	30 (1.18)	32 (1.26)
-	156-45	12 (0.47)	30 (1.18)
-	156-46	30 (1.18)	32 (1.26)
-	156-51	12 (0.47)	30 (1.18)
-	156-52	30 (1.18)	32 (1.26)
-	156-61	12 (0.47)	30 (1.18)
-	156-62	30 (1.18)	32 (1.26)
-	156-72	30 (1.18)	32 (1.26)

OPTION TO STANDARD PART  
FILLER PORT (CODE P)

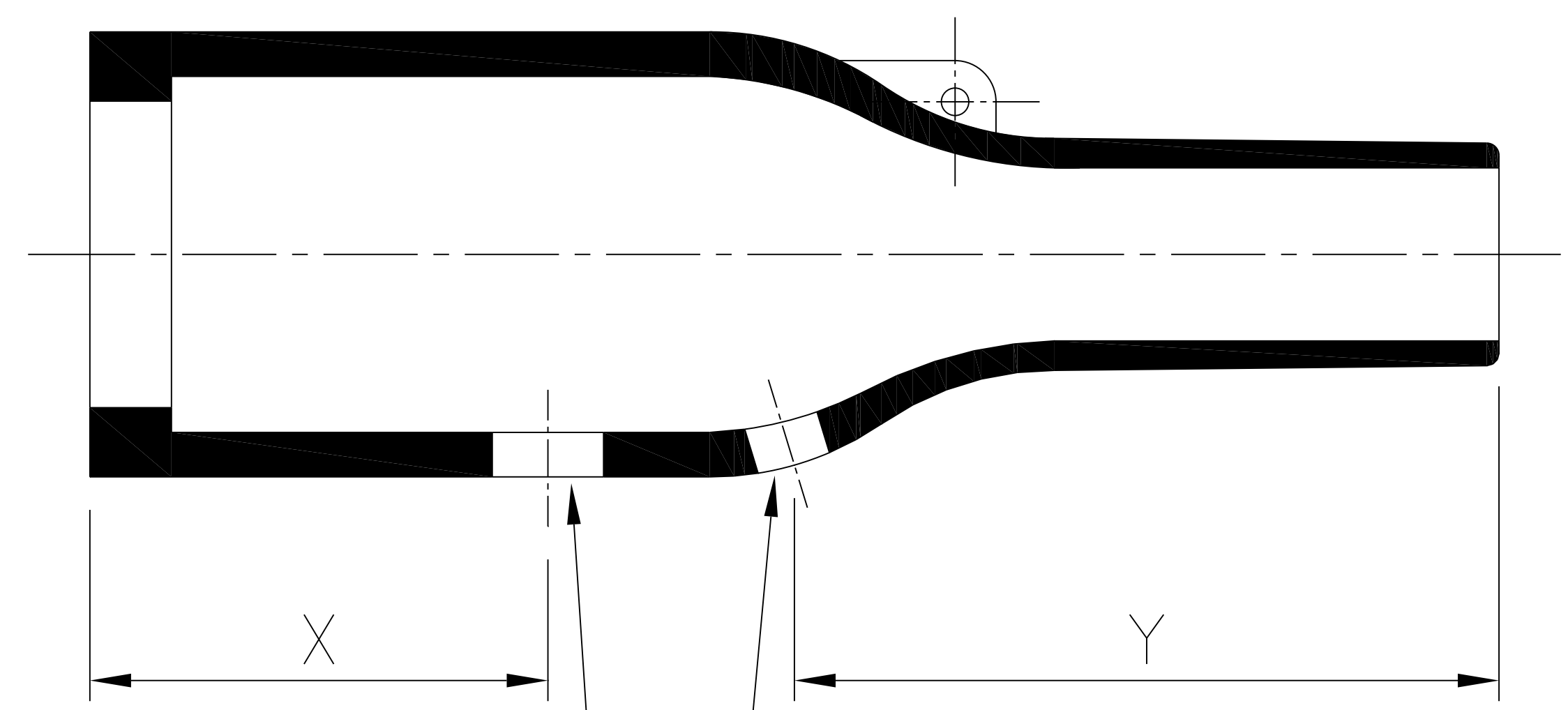

1 FILLER PORT  
 $\phi 4.5$  NOM (0.18)  
1 DRAIN HOLE  
 $\phi 3.0$  NOM (0.12)

SPEC.	PART No.	EXPANDED DIAMETERS (AS SUPPLIED)		RECOVERED DIAMETERS		RECOVERED DIMENSIONS						
		$\phi h$	$\phi j$	$\phi H$	$\phi J$	P	R	S	T	V	Hw	Jw
		MIN	MIN	MAX	MAX	$\pm 10\%$	NOM	NOM	$\pm 20\%$	MAX	$\pm 20\%$	$\pm 30\%$
VG 95343 T06A005A	156-41	36 (1.42)	36 (1.42)	22.5 (0.88)	8.5 (0.33)	60 (2.36)	22 (0.87)	20 (0.79)	1.0 (0.04)	3.3 (0.13)	2.0 (0.08)	1.0 (0.04)
VG 95343 T06B005A	156-42	36 (1.42)	36 (1.42)	22.5 (0.88)	8.5 (0.33)	80 (3.15)	42 (1.65)	20 (0.79)	1.0 (0.04)	3.3 (0.13)	2.0 (0.08)	1.0 (0.04)
-	156-45	26 (1.02)	12 (0.47)	22.5 (0.88)	8.5 (0.33)	60 (2.36)	22 (0.87)	20 (0.79)	1.0 (0.04)	3.3 (0.13)	2.0 (0.08)	1.0 (0.04)
-	156-46	26 (1.02)	12 (0.47)	22.5 (0.88)	8.5 (0.33)	80 (3.15)	42 (1.65)	20 (0.79)	1.0 (0.04)	3.3 (0.13)	2.0 (0.08)	1.0 (0.04)
-	156-51	34 (1.34)	17 (0.67)	22.5 (0.88)	8.5 (0.33)	60 (2.36)	22 (0.87)	20 (0.79)	1.0 (0.04)	3.3 (0.13)	2.0 (0.08)	1.1 (0.04)
-	156-52	34 (1.34)	17 (0.67)	22.5 (0.88)	8.5 (0.33)	80 (3.15)	42 (1.65)	20 (0.79)	1.0 (0.04)	3.3 (0.13)	2.0 (0.08)	1.1 (0.04)
VG 95343 T29A005A	156-61	36 (1.42)	21 (0.83)	22.5 (0.88)	8.5 (0.33)	60 (2.36)	22 (0.87)	20 (0.79)	1.0 (0.04)	3.3 (0.13)	2.0 (0.08)	1.0 (0.04)
VG 95343 T29B005A	156-62	36 (1.42)	21 (0.83)	22.5 (0.88)	8.5 (0.33)	80 (3.15)	42 (1.65)	20 (0.79)	1.0 (0.04)	3.3 (0.13)	2.0 (0.08)	1.0 (0.04)
-	156-72	41 (1.61)	41 (1.61)	22.5 (0.88)	8.5 (0.33)	80 (3.15)	42 (1.65)	20 (0.79)	1.0 (0.04)	3.3 (0.13)	2.0 (0.08)	1.0 (0.04)

6	P1524	GB	22/10/15
5	P1499	GL	24/02/15
4	P1366	CM	25/11/11
3	P1362	DJC	05/10/11
2	P1329	G.B.	11/10/10
ISSUE	NOTE No.	DRAWN	DATE

**HellermannTyton**

William Prance Road,  
Plymouth International Med. & Tech. Park,  
Plymouth, PL6 5WR  
Tel ++44 (0) 1752 701261  
Fax ++44 (0) 1752 790058

NAME	S.Almond	SCALE	NTS
DATE	14/04/08	DIMS IN	mm (in)
TITLE	BOTTLE SLEEVE		

ADHESIVE	A3	SHT. 1
	ORIGINAL SHEET SIZE 420mm x 297mm	OF 1 SHTS.
PART No.	156	DRAWING No.
		152087