

DRAWING No.
152088

SHT. 1
OF
1 SHTS.

© THE COPYRIGHT OF THIS DRAWING IS RESERVED BY HELLERMANN TYTON. IT IS ISSUED ON CONDITION THAT IT IS NOT COPIED, REPRODUCED OR DISCLOSED TO A THIRD PARTY EITHER WHOLLY OR IN PART WITHOUT THE CONSENT IN WRITING OF HELLERMANN TYTON.

THIRD ANGLE PROJECTION

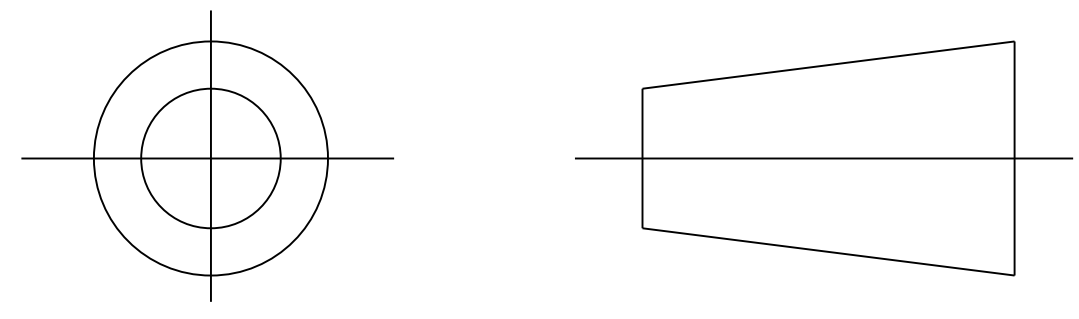

BS 8888

DO NOT SCALE
IF IN DOUBT ASK

Q.A.	H/S SETT	
H/S Q.A.	REL. INSP.	
H/S PROD	EXT. ISS. CODE	5, 7, 12

STANDARD PART (AFTER UNRESTRICTED RECOVERY)

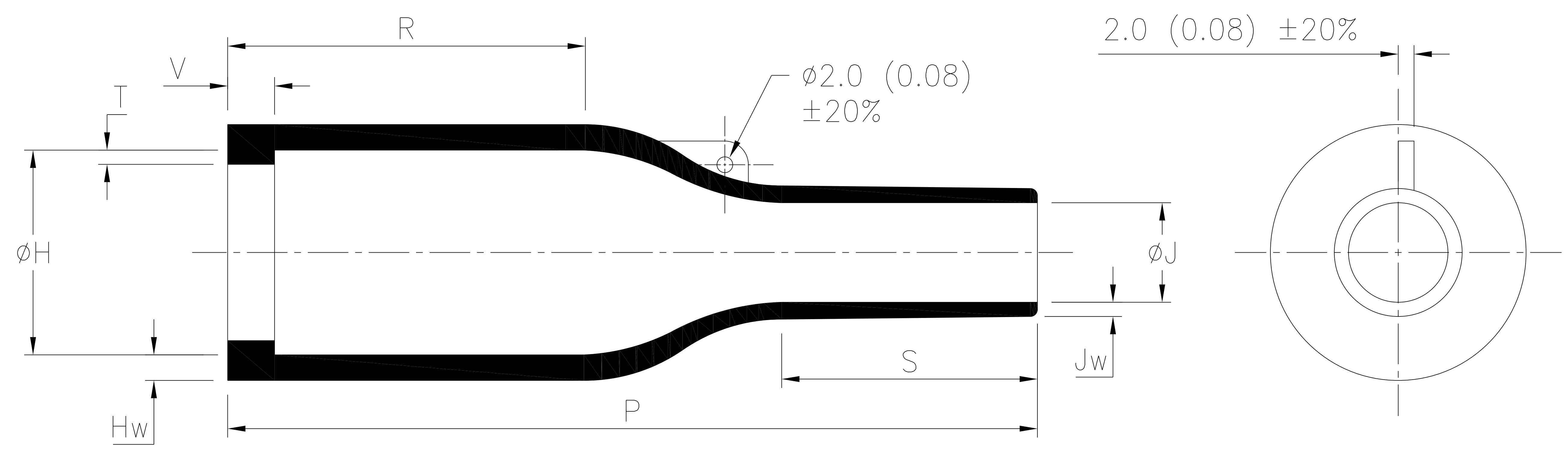

EXPANDED (AS SUPPLIED)

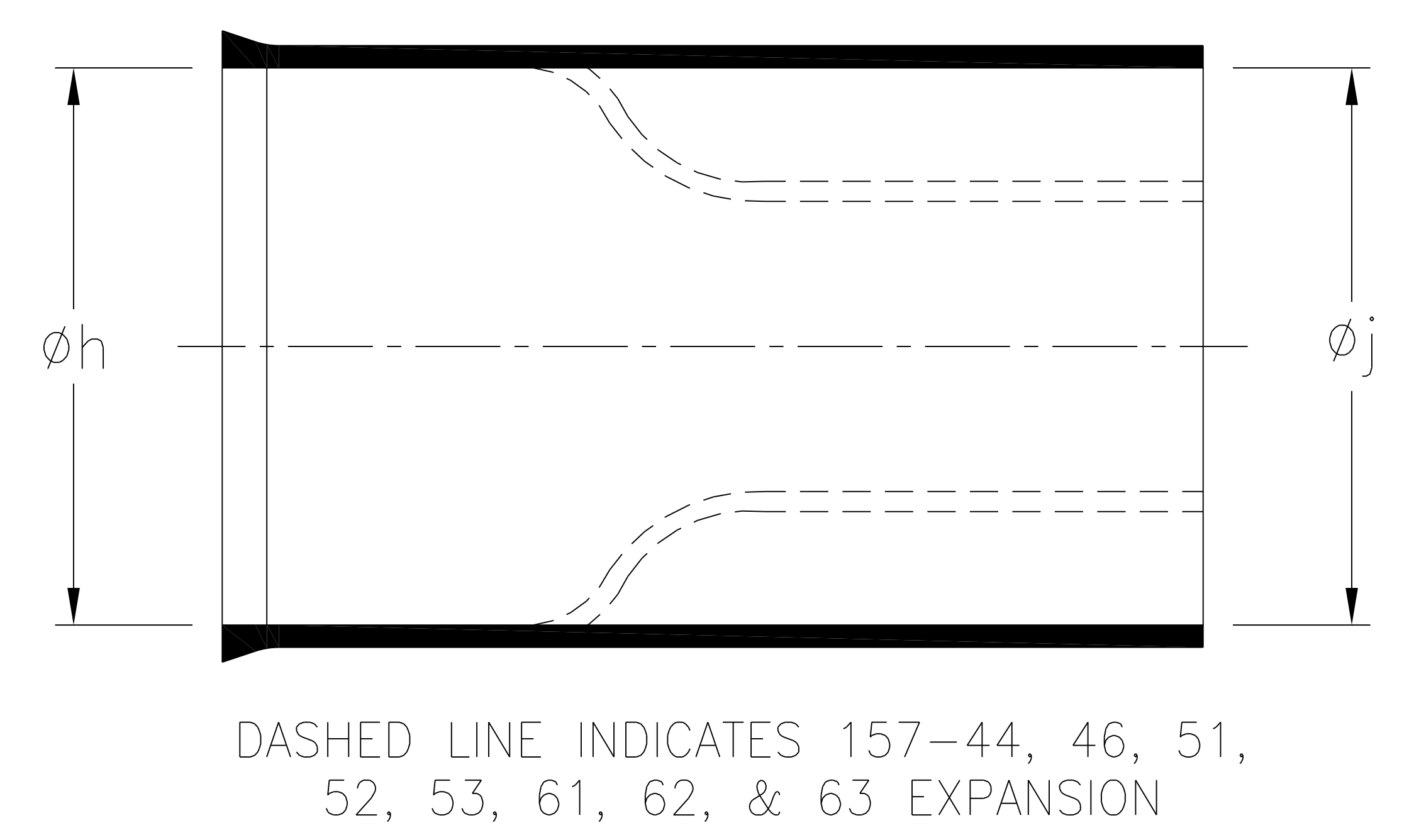

SPEC.	PART No.	EXPANDED DIAMETERS (AS SUPPLIED)		RECOVERED DIAMETERS		RECOVERED DIMENSIONS						
		ϕh	ϕj	ϕH	ϕJ	P	R	S	T	V	Hw	Jw
		MIN	MIN	MAX	MAX	$\pm 10\%$	NOM	NOM	$\pm 20\%$	MAX	$\pm 20\%$	$\pm 30\%$
VG 95343 T06A006A	157-41	43 (1.69)	43 (1.69)	28 (1.10)	10 (0.39)	60 (2.36)	21 (0.83)	20 (0.79)	1.7 (0.07)	3.3 (0.13)	2.2 (0.09)	1.0 (0.04)
VG 95343 T06B006A	157-42	43 (1.69)	43 (1.69)	28 (1.10)	10 (0.39)	79 (3.11)	41 (1.61)	20 (0.79)	1.7 (0.07)	3.3 (0.13)	2.2 (0.09)	1.0 (0.04)
VG 95343 T06C001A	157-43	43 (1.69)	43 (1.69)	28 (1.10)	10 (0.39)	99 (3.90)	61 (2.40)	20 (0.79)	1.7 (0.07)	3.3 (0.13)	2.2 (0.09)	1.0 (0.04)
-	157-44	32 (1.26)	18 (0.71)	28 (1.10)	10 (0.39)	99 (3.90)	61 (2.40)	20 (0.79)	1.7 (0.07)	3.3 (0.13)	2.2 (0.09)	1.0 (0.04)
-	157-46	32 (1.26)	18 (0.71)	28 (1.10)	10 (0.39)	79 (3.11)	41 (1.61)	20 (0.79)	1.7 (0.07)	3.3 (0.13)	2.2 (0.09)	1.0 (0.04)
-	157-48	50.4 (2.00)	50.4 (2.00)	28 (1.10)	10 (0.39)	99 (3.90)	61 (2.40)	20 (0.79)	1.7 (0.07)	3.3 (0.13)	2.2 (0.09)	1.0 (0.04)
-	157-51	42 (1.65)	20 (0.79)	28 (1.10)	10.5 (0.41)	60 (2.36)	21 (0.83)	20 (0.79)	1.7 (0.07)	3.3 (0.13)	2.2 (0.09)	1.0 (0.04)
-	157-52	42 (1.65)	20 (0.79)	28 (1.10)	10.5 (0.41)	79 (3.11)	41 (1.61)	20 (0.79)	1.7 (0.07)	3.3 (0.13)	2.2 (0.09)	1.0 (0.04)
-	157-53	42 (1.65)	20 (0.79)	28 (1.10)	10.5 (0.41)	99 (3.90)	61 (2.40)	20 (0.79)	1.7 (0.07)	3.3 (0.13)	2.2 (0.09)	1.0 (0.04)
VG 95343 T29A006A	157-61	43 (1.69)	25 (0.98)	28 (1.10)	10 (0.39)	60 (2.36)	21 (0.83)	20 (0.79)	1.7 (0.07)	3.3 (0.13)	2.2 (0.09)	1.0 (0.04)
VG 95343 T29B006A	157-62	43 (1.69)	25 (0.98)	28 (1.10)	10 (0.39)	79 (3.11)	41 (1.61)	20 (0.79)	1.7 (0.07)	3.3 (0.13)	2.2 (0.09)	1.0 (0.04)
VG 95343 T29C001A	157-63	43 (1.69)	25 (0.98)	28 (1.10)	10 (0.39)	99 (3.90)	61 (2.40)	20 (0.79)	1.7 (0.07)	3.3 (0.13)	2.2 (0.09)	1.0 (0.04)

OPTIONAL FILLER PORT DETAIL

SPEC.	PART No.	RECOVERED DIMENSIONS	
		X	Y
		$\pm 20\%$	$\pm 20\%$
VG 95343 T07A006A	157-41	12 (0.47)	30 (1.18)
VG 95343 T07B006A	157-42	30 (1.18)	32 (1.26)
VG 95343 T07C001A	157-43	52 (2.05)	30 (1.18)
-	157-44	52 (2.05)	30 (1.18)
-	157-46	30 (1.18)	32 (1.26)
-	157-48	52 (2.05)	30 (1.18)
-	157-51	12 (0.47)	30 (1.18)
-	157-52	30 (1.18)	32 (1.26)
-	157-53	52 (2.05)	30 (1.18)
-	157-61	12 (0.47)	30 (1.18)
-	157-62	30 (1.18)	32 (1.26)
-	157-63	52 (2.05)	30 (1.18)

OPTION TO STANDARD PART
FILLER PORT (CODE P)

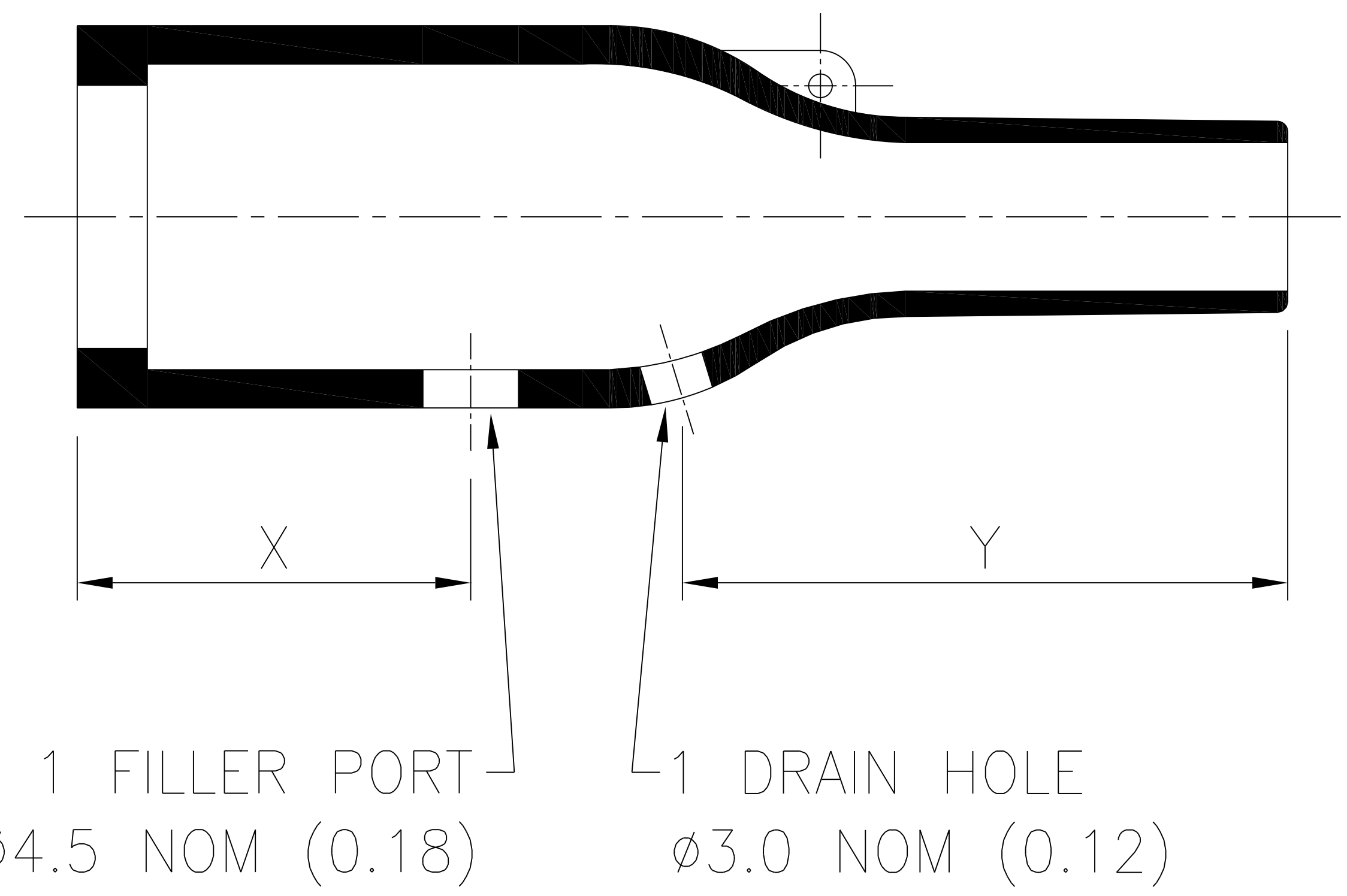

5	P1499	GL	24/02/15
4	P1399	CM	03/01/13
3	P1362	DJC	05/10/11
2	P1329	G.B.	11/10/10
1	P1195	S.Almond	14/04/08
ISSUE	NOTE No.	DRAWN	DATE

HellermannTyton
William Prance Road,
Plymouth International Med. & Tech. Park,
Plymouth, PL6 5WR
Tel ++44 (0) 1752 701261
Fax ++44 (0) 1752 790058

NAME	S.Almond	SCALE	NTS	ADHESIVE	A3 ORIGINAL SHEET SIZE 420mm x 297mm	SHT. 1 OF 1 SHTS.
DATE	14/04/08	DIMS IN	mm (in)			
TITLE	BOTTLE SLEEVE			PART No.	DRAWING No.	
				157	152088	