

F (20 : 1)

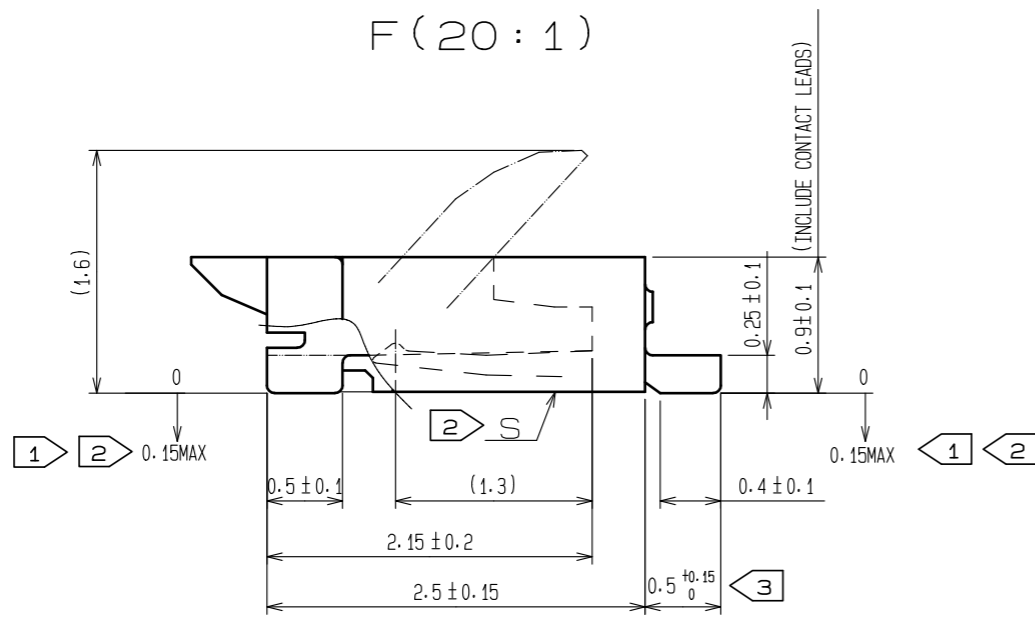

- NOTES
- ① LEAD CO-PLANARITY INCLUDING REINFORCED METAL FITTINGS SHALL BE 0.1 MAX.
 - ② DIMENSION: FROM REFERENCE S.
 - ③ DIFFERENCE OF EACH CONTACT LEAD TO BE MAX 0.1.
 - 4 TO BE DELIVERED WITH TAPE AND REEL PACKAGES. SEE ATTACHED PACKAGING SPECIFICATIONS FOR DETAILS.
 - 5 NOTE THAT PREVENTIVE HOLE FOR SINK MARK COULD BE ADDED FOR IMPROVEMENT.
 - 6 THIS PRODUCT SATISFIES HALOGEN FREE REQUIREMENTS DEFINED AS 900 PPM MAXIMUM CHLORINE, 900 PPM MAXIMUM BROMINE, AND 1500 PPM MAXIMUM TOTAL OF CHLORINE AND BROMINE.
 - 7 THE DIMENSIONS IN PARENTHESES ARE FOR REFERENCE.

RECOMMENDED LAND PATTERN, METAL MASK (FREE)

RECOMMENDED METAL MASK THICKNESS: t=0.10

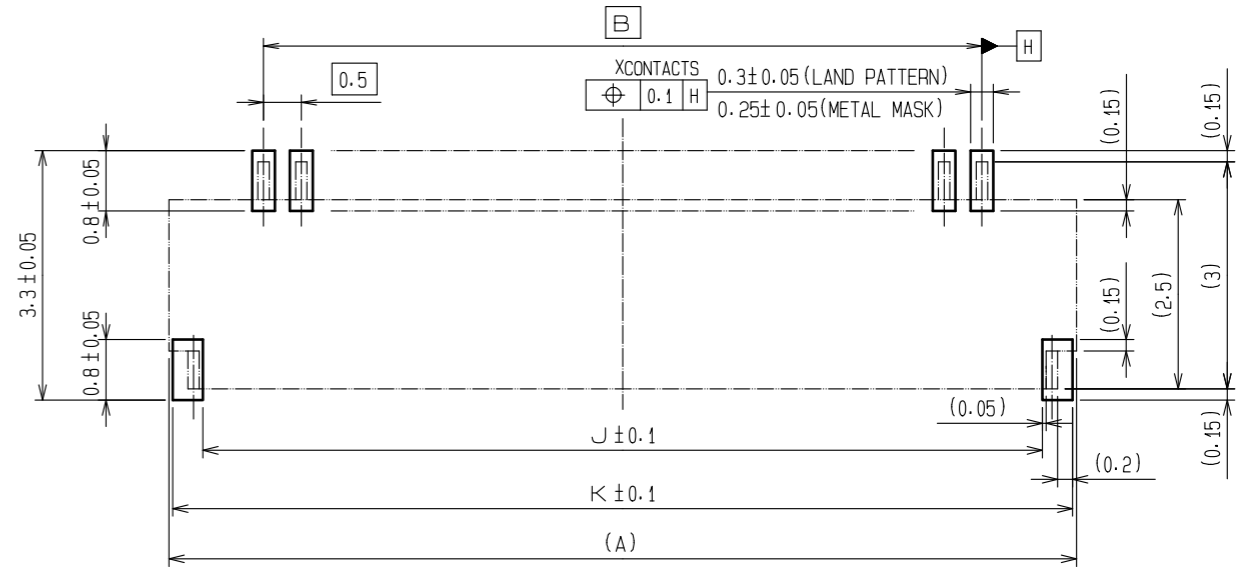

RECOMMENDED FPC (FREE)

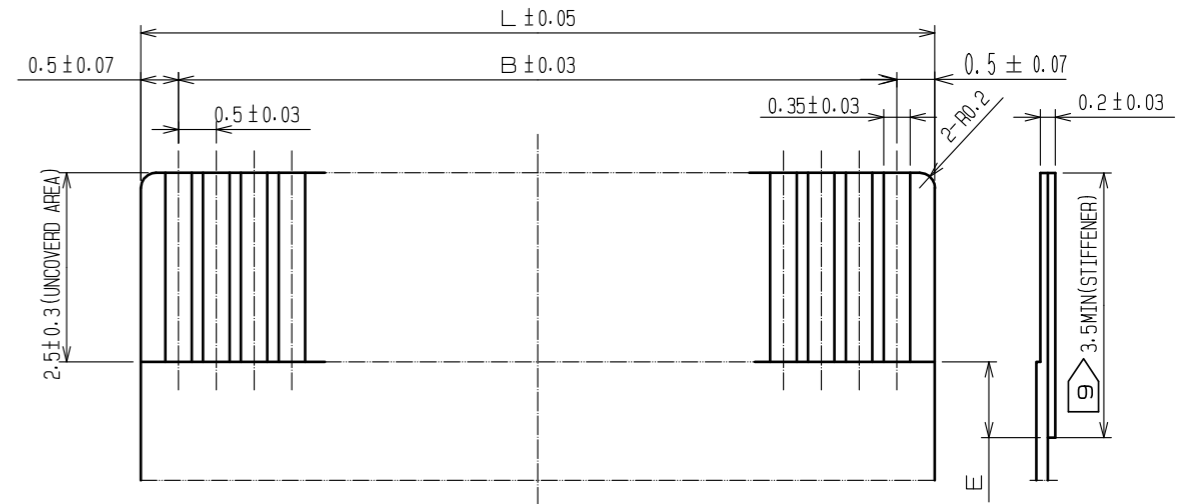

- 8 FOR FPC APPLICATION, STIFFENER MATERIAL IS POLYIMID, HEAT CURED ADHESIVE.
- ⑨ DIMENSION E MUST BE 0.5mm MINIMUM WHEN THE STIFFENER IS SHORTER THAN 3.5mm

4	PHOSPHOR BRONZE (PLATED MATERIAL)	TIN PLATING (REFLOW FINISHED) 1μm MIN OVER COPPER 0.5μm MIN	9	(CONNECTOR)	
			8	POLYSTYRENE	
3	PHOSPHOR BRONZE	(CONTACT AREA LEAD) GOLD PLATING 0.05μm MIN OVER NICKEL 1μm MIN (OTHER) NICKEL PLATING 1μm MIN	7	POLYESTER	
			6	POLYSTYRENE	
2	LCP	BROWN UL94V-0	5	PHOSPHOR BRONZE (PLATED MATERIAL)	TIN PLATING (REFLOW FINISHED) 1μm MIN OVER COPPER 0.5μm MIN
1	LCP	BEIGE UL94V-0			
NO.	MATERIAL	FINISH . REMARKS	NO.	MATERIAL	FINISH . REMARKS
UNITS mm		SCALE 5 : 1	COUNT		DESCRIPTION OF REVISIONS
					DESIGNED
					CHECKED
					DATE
APPROVED : NF. MIYAZAKI		16.03.31	DRAWING NO. EDC-155218-99-00		
CHECKED : YH. MICHIDA		16.03.30	PART NO. FH19C-**-S-0.5SH(99)		
DESIGNED : KN. KOBAYASHI		16.03.30	CODE NO. CL580		
DRAWN : RN. IIDA		16.03.24			

EMBOSSED CARRIER TAPE DIMENSIONS (2:1)

● TAPE WIDTH : 24mm MAX

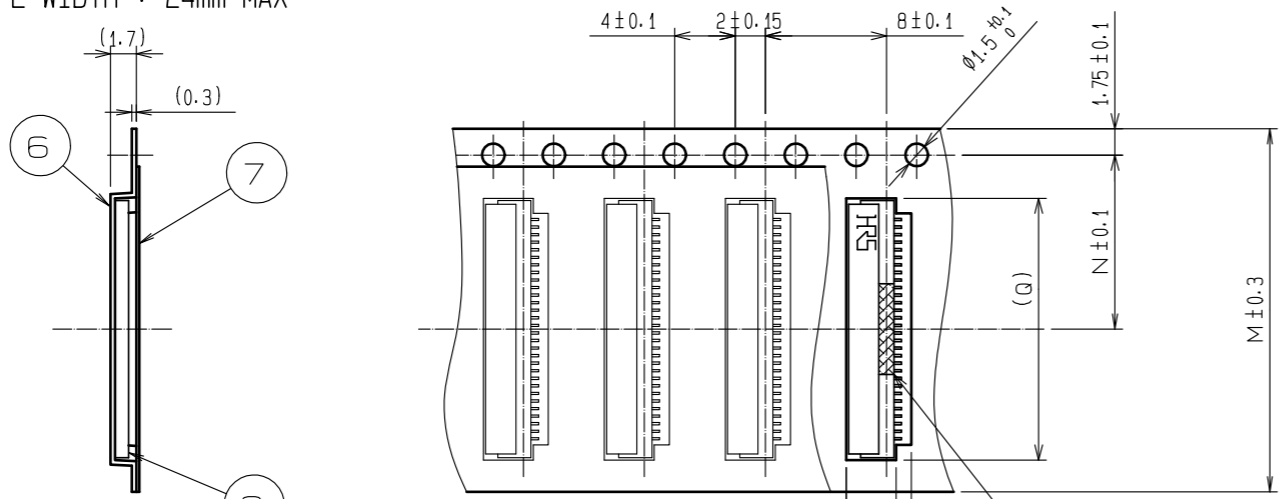

● TAPE WIDTH : 32mm MIN

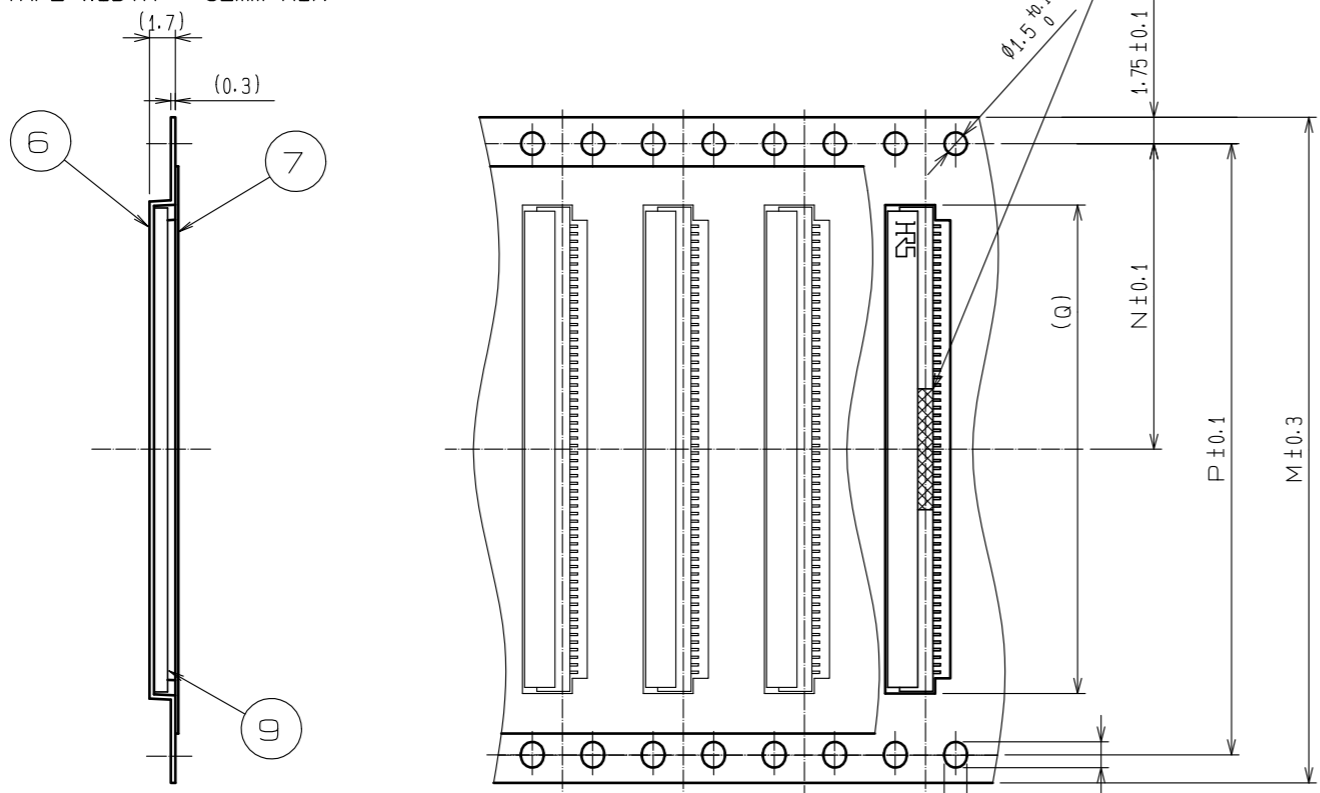

DIRECTION OF UNREELING

VACUUM PICK UP AREA

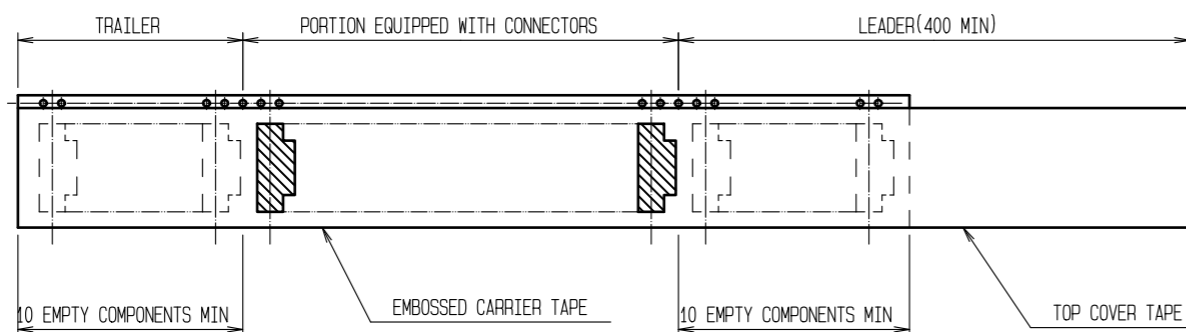

REEL DIMENSIONS (FREE)

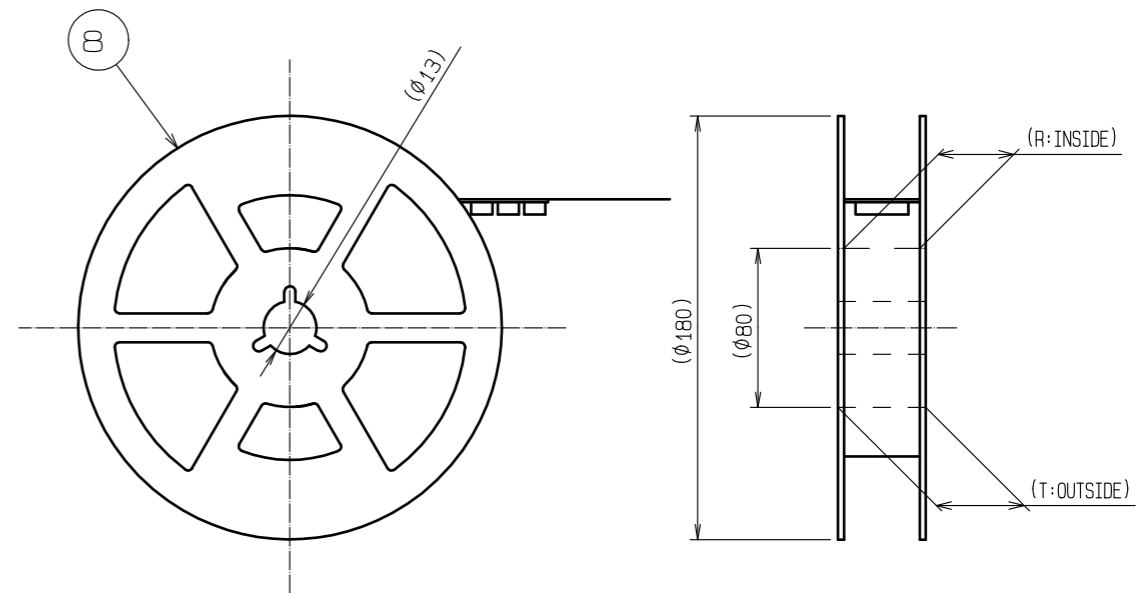

- NOTE 10 PER REEL : 500 CONNECTORS.
 11 REFER TO JIS C 0806 and IEC 60286-3 (PACKAGING OF COMPONENTS FOR AUTOMATIC HANDLING.)

<DRAWING FOR PACKING>

HRS	DRAWING NO.	EDC-155218-99-00
	PART NO.	FH19C-***S-0.5SH(99)
	CODE NO.	CL580
		2/7

DIMENSION TABLE OF CONNECTOR, FPC, LAND PATTERN AND METAL MASK

PART No.	CODE No.	*	A	B	C	D	J	K	L
FH19C- 4S-0.5SH(99)	CL580-0410-1-99	4	4	1.5	2.57	3.35	3.1	3.9	2.5
FH19C- 5S-0.5SH(99)	CL580-0418-3-99	5	4.5	2	3.07	3.85	3.6	4.4	3
FH19C- 6S-0.5SH(99)	CL580-0409-2-99	6	5	2.5	3.57	4.35	4.1	4.9	3.5
FH19C- 7S-0.5SH(99)	CL580-0411-4-99	7	5.5	3	4.07	4.85	4.6	5.4	4
FH19C- 8S-0.5SH(99)	CL580-0404-9-99	8	6	3.5	4.57	5.35	5.1	5.9	4.5
FH19C- 9S-0.5SH(99)	CL580-0403-6-99	9	6.5	4	5.07	5.85	5.6	6.4	5
FH19C-10S-0.5SH(99)	CL580-0412-7-99	10	7	4.5	5.57	6.35	6.1	6.9	5.5
FH19C-12S-0.5SH(99)	CL580-0413-0-99	12	8	5.5	6.57	7.35	7.1	7.9	6.5
FH19C-13S-0.5SH(99)	CL580-0405-1-99	13	8.5	6	7.07	7.85	7.6	8.4	7
FH19C-15S-0.5SH(99)	CL580-0406-4-99	15	9.5	7	8.07	8.85	8.6	9.4	8
FH19C-17S-0.5SH(99)	CL580-0408-0-99	17	10.5	8	9.07	9.85	9.6	10.4	9
FH19C-20S-0.5SH(99)	CL580-0402-3-99	20	12	9.5	10.57	11.35	11.1	11.9	10.5
FH19C-21S-0.5SH(99)	CL580-0414-2-99	21	12.5	10	11.07	11.85	11.6	12.4	11
FH19C-24S-0.5SH(99)	CL580-0407-7-99	24	14	11.5	12.57	13.35	13.1	13.9	12.5
FH19C-27S-0.5SH(99)	CL580-0401-0-99	27	15.5	13	14.07	14.85	14.6	15.4	14
FH19C-30S-0.5SH(99)	CL580-0400-8-99	30	17	14.5	15.57	16.35	16.1	16.9	15.5
FH19C-34S-0.5SH(99)	CL580-0419-6-99	34	19	16.5	17.57	18.35	18.1	18.9	17.5
FH19C-40S-0.5SH(99)	CL580-0416-8-99	40	22	19.5	20.57	21.35	21.1	21.9	20.5
FH19C-50S-0.5SH(99)	CL580-0417-0-99	50	27	24.5	25.57	26.35	26.1	26.9	25.5

DIMENSION TABLE OF DRAWING FOR PACKING

PART No.	CODE No.	*	M	N	P	Q	R	T
FH19C- 4S-0.5SH(99)	CL580-0410-1-99	4	16	7.5	—	4.3	17.4	21.4
FH19C- 5S-0.5SH(99)	CL580-0418-3-99	5	16	7.5	—	4.8	17.4	21.4
FH19C- 6S-0.5SH(99)	CL580-0409-2-99	6	16	7.5	—	5.3	17.4	21.4
FH19C- 7S-0.5SH(99)	CL580-0411-4-99	7	16	7.5	—	5.8	17.4	21.4
FH19C- 8S-0.5SH(99)	CL580-0404-9-99	8	16	7.5	—	6.3	17.4	21.4
FH19C- 9S-0.5SH(99)	CL580-0403-6-99	9	16	7.5	—	6.8	17.4	21.4
FH19C-10S-0.5SH(99)	CL580-0412-7-99	10	16	7.5	—	7.3	17.4	21.4
FH19C-12S-0.5SH(99)	CL580-0413-0-99	12	16	7.5	—	8.3	17.4	21.4
FH19C-13S-0.5SH(99)	CL580-0405-1-99	13	16	7.5	—	8.8	17.4	21.4
FH19C-15S-0.5SH(99)	CL580-0406-4-99	15	16	7.5	—	9.8	17.4	21.4
FH19C-17S-0.5SH(99)	CL580-0408-0-99	17	24	11.5	—	10.8	25.4	29.4
FH19C-20S-0.5SH(99)	CL580-0402-3-99	20	24	11.5	—	12.3	25.4	29.4
FH19C-21S-0.5SH(99)	CL580-0414-2-99	21	24	11.5	—	12.8	25.4	29.4
FH19C-24S-0.5SH(99)	CL580-0407-7-99	24	24	11.5	—	14.3	25.4	29.4
FH19C-27S-0.5SH(99)	CL580-0401-0-99	27	24	11.5	—	15.8	25.4	29.4
FH19C-30S-0.5SH(99)	CL580-0400-8-99	30	24	11.5	—	17.3	25.4	29.4
FH19C-34S-0.5SH(99)	CL580-0419-6-99	34	32	14.2	28.4	19.3	33.4	37.4
FH19C-40S-0.5SH(99)	CL580-0416-8-99	40	44	20.2	40.4	22.3	45.4	49.4
FH19C-50S-0.5SH(99)	CL580-0417-0-99	50	44	20.2	40.4	27.3	45.4	49.4

*: NUMBER OF CONTACTS

HRS	DRAWING NO.	EDC-155218-99-00
	PART NO.	FH19C-***S-0.5SH(99)
	CODE NO.	CL580
		3/7

This connector is small and thin and requires delicate and careful handling. Read through the instructions shown below and handle the connector properly. Each values indicating here are for reference and may differ from standard value.

[INSTRUCTIONS FOR MOUNTING ON THE BOARD]

◆Warp of Board

Minimize warp of the board as much as possible.
Lead co-planarity including reinforced metal fittings is 0.1 mm or less.
Too much warp of the board may result in a soldering failure.

◆Flexible board design

Please make sure to put a stiffener on the backside of the flexible board.
We recommend a glass epoxy material with the thickness of 0.3mm MIN.

◆Load to Connector

Do not add 1N or greater external force when unreel or pick and place the connector etc. or it may get broken.
In addition, do not insert the FPC or operate the connector before mounting it.

[INSTRUCTIONS FOR PCB HANDLING AFTER MOUNTING THE CONNECTOR]

◆Load to Board

- Splitting a large board into several pieces
 - Screwing the board
- Avoid the handling described above so that no force is exerted on the board during the assembly process. Otherwise, the connector may become defective.

◆Amount of Warp

The warp of a 100mm wide board should be 1 mm or less.
The warp of board suffers stress on connector and the connector may become defective.

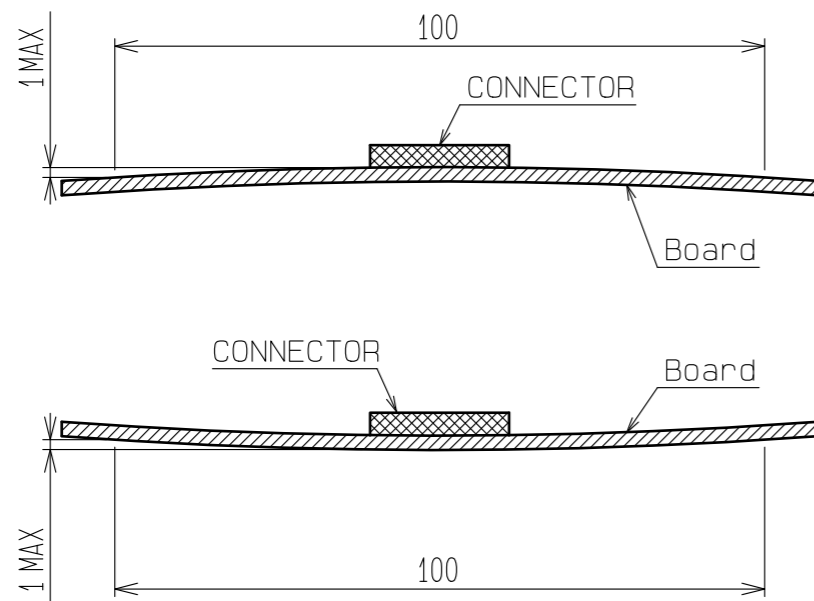

[INSTRUCTIONS ON INSERTING FPC AND CONNECTION]

◆ Use of the actuator

1. Be very careful not to apply excessive force when releasing the actuator in the initial position (with no FPC inserted).
If you use your nail or finger or pair of tweezers as shown below, the terminals may be deformed.

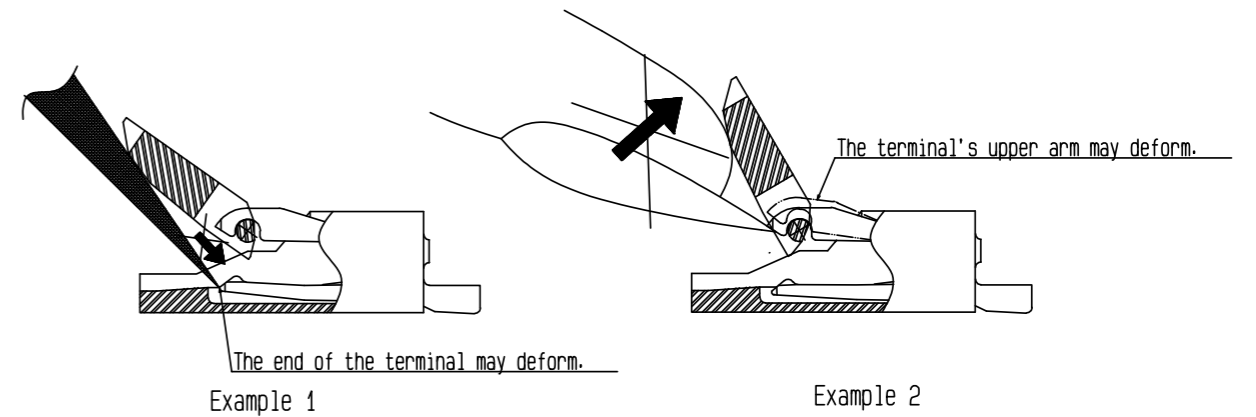

2. When operating the actuator, do not apply a force in the direction of the connector. The actuator may get pushed into the connector, causing damage to the connector.

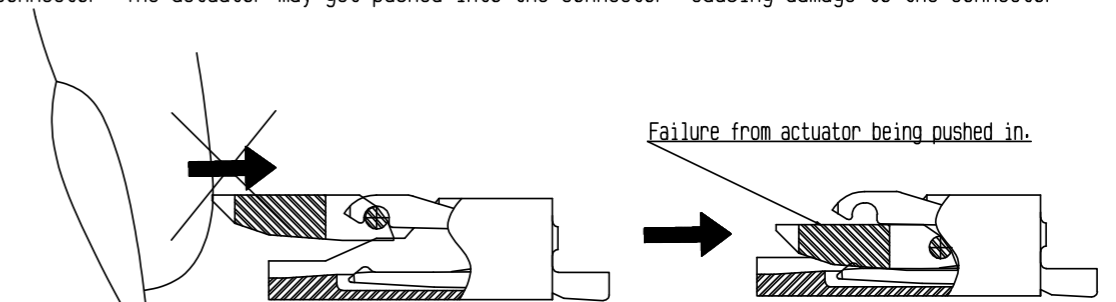

The actuator is designed to rotate on the axis shown in the figure below so make sure to use a rotating motion when operating it.

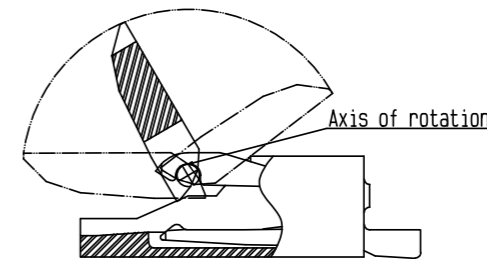

<INSTRUCTION MANUAL>

HRS	DRAWING NO.	EDC-155218-99-00
	PART NO.	FH19C-***S-0.5SH(99)
	CODE NO.	CL580
		4/7

3. The actuator is not designed to open more than 130 degrees, so do not push it back further than this. Doing so may result in deformed terminals, actuator break-off or other damage.

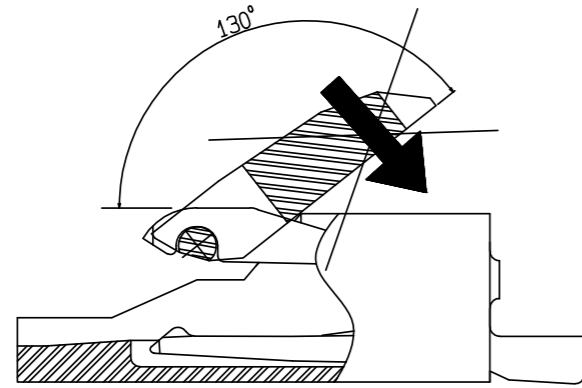

4. When operating the actuator, avoid operating it at its end. Make sure to operate it at its middle section.

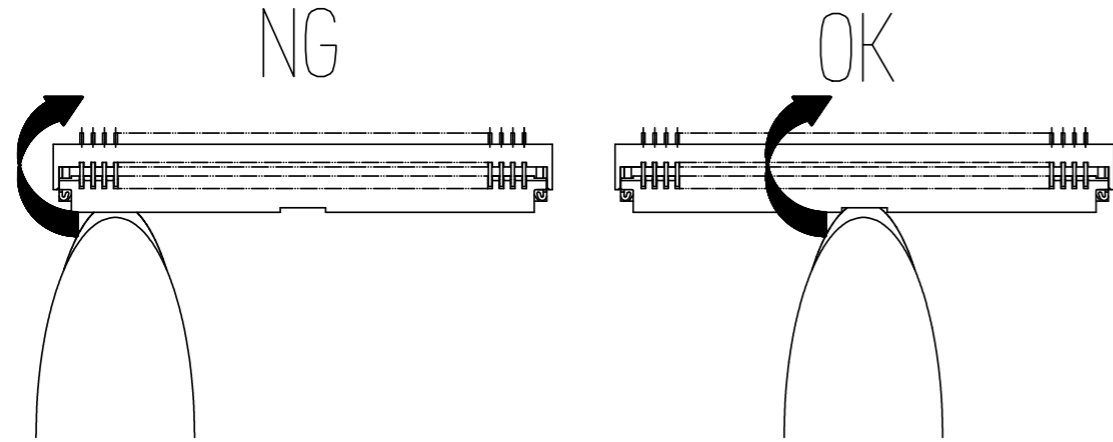

5. Do not lift or snag the actuator as shown in the figures below. This can result in damage. (Operate the actuator only in a rotating fashion as instructed in paragraph 2 above.)

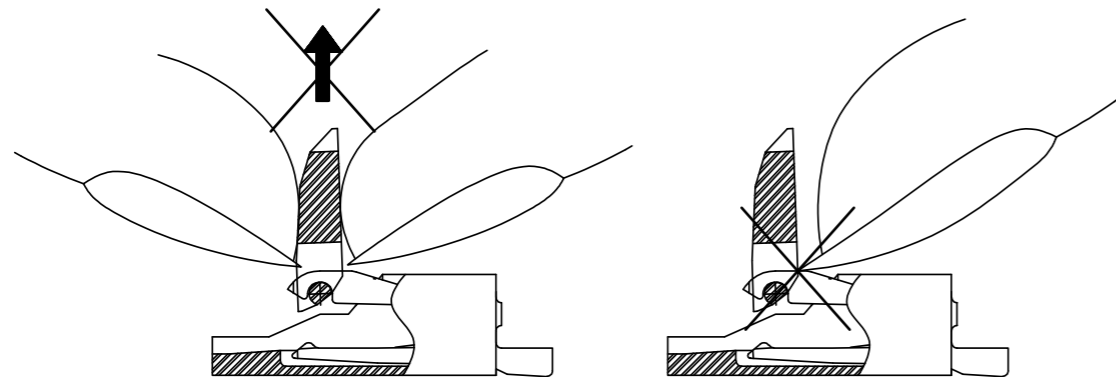

◆ Contact orientation

This connector is configured with its contacts at the bottom. Therefore, insert the FPC with the side with the exposed conductors facing down.

◆ Inserting an FPC

1. Insert the FPC parallel to the board and perpendicular to the connector, and press it in securely and fully. Inserting the FPC at an angle may result in shorts due to pitch displacements or the FPC's edges snagging the terminal and causing them to deform. This connector has a ZIF structure with an effective engagement length of 1.3mm (at the nominal FPC dimension recommended by Hirose). Therefore, operate the actuator with care after the FPC has been inserted so that the FPC does not pull loose.

2. When inserting the FPC, make sure not to bump the FPC's tip against the upper arm area of the terminal. This may cause the terminal to deform.

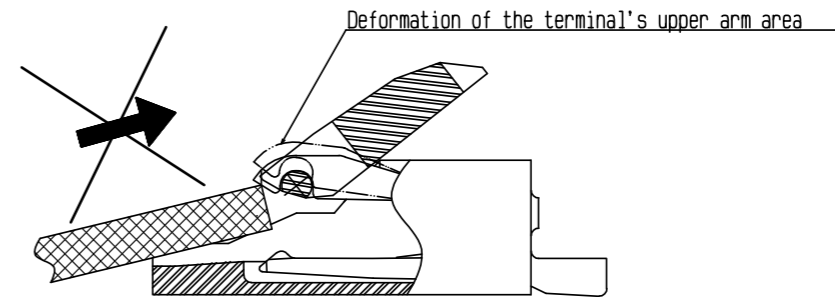

3. Do not insert the FPC at an angle.

Do not insert the FPC from above at an angle as shown in the figure. This may cause the FPC to bend or the terminal to deform. Additionally, the FPC may not insert all the way and result in discontinuation.

* Please design the layout to provide for enough space for the FPC so that it will not have to be inserted at an angle.

* Please speak with your FPC manufacturer for FPC bendability.

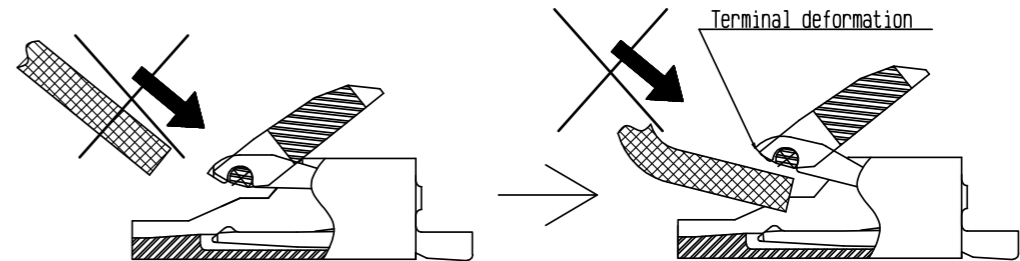

<INSTRUCTION MANUAL>

HRS	DRAWING NO.	EDC-155218-99-00
	PART NO.	FH19C-***S-0.5SH(99)
	CODE NO.	CL580
		5/7

4. When inserting (or removing) an FPC using a pair of tweezers, once the tip of the FPC is inside the connector, do not hold the FPC at an area above the connector (higher than 1mm from the board), twist the FPC or apply upward force. The upper arm area of the terminal will deform and compromise reliability.

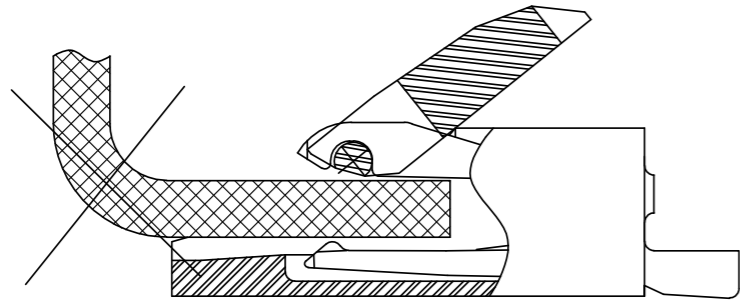

5. When inserting an FPC, do not use the method shown in the figure on the left below where the corner of the FPC is inserted first and then slid sideways. The FPC's corner can deform the terminal's contacts. Always insert the FPC parallel to the board as shown in the figure on the right below.

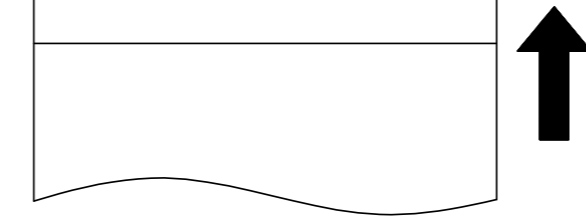
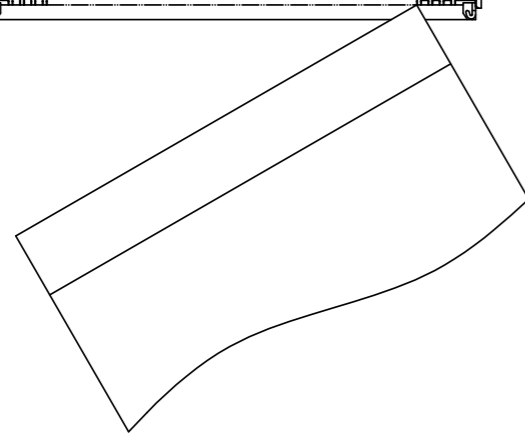

[Reminders on operating the lock]

◆ Actuator operation
Once the FPC is attached, do not operate the end of the actuator as shown in the figure on the left below to close the lock. This can cause damage to the actuator. Always operate the middle area of the actuator as shown in the figure on the right when operating the lock.

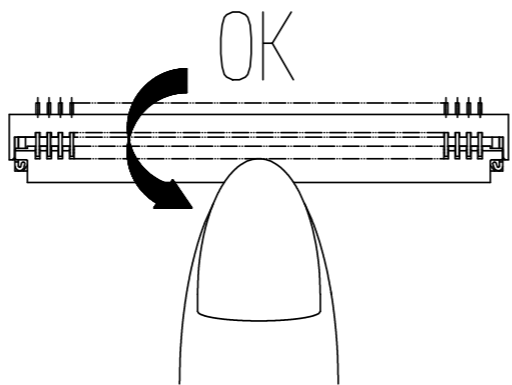
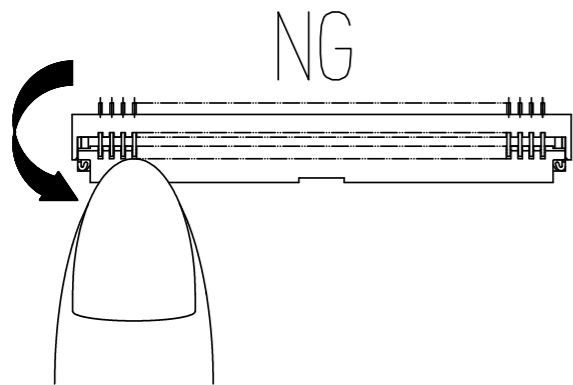

◆ Confirming the state of the lock
Once it is locked, make sure that the actuator is parallel to the board. However, if the actuator approaches 0 degrees, make sure that it is not.

[Reminders on FPC routing after it has been connected]

◆ Loads applied to the FPC
Once the FPC is attached, make sure that it is not subjected to loads. This can cause the connector lock to disengage, or cause a discontinuation or damage to the FPC. If the FPC is subjected to a constant load, fasten the FPC in place. When routing the FPC, make sure that it is not forced to make a tight bend at the FPC connection.

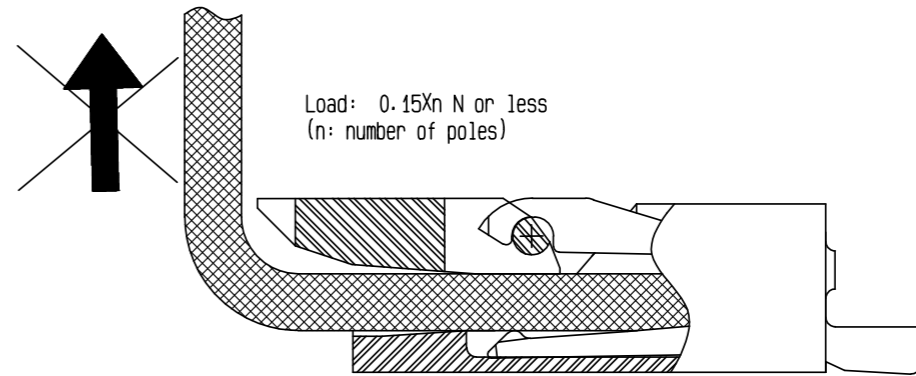

[Reminders on releasing the lock]

◆ Operating the actuator
1. Do not operate the end of the actuator as shown in the figure on the left below when releasing the lock. This can cause damage to the actuator. Always operate the middle area of the actuator as shown in the figure on the right when operating the lock.

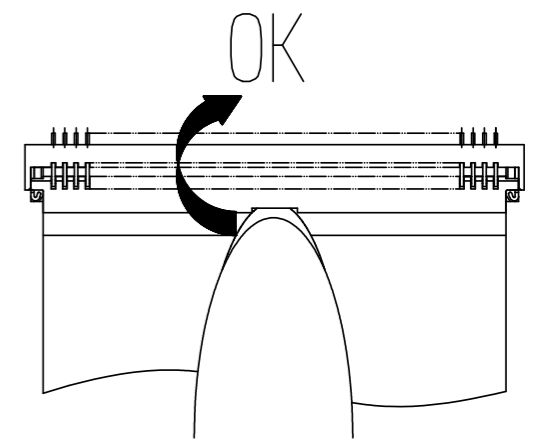
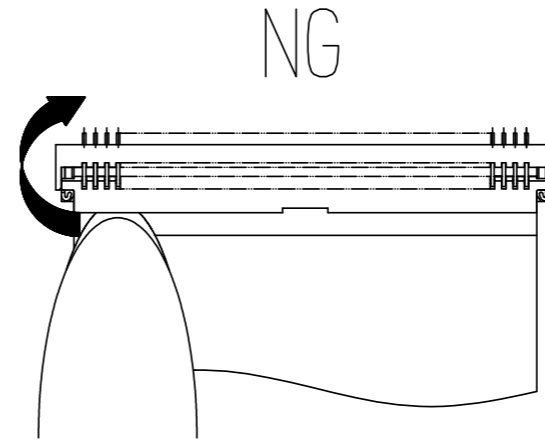

<INSTRUCTION MANUAL>

HRS	DRAWING NO.	EDC-155218-99-00
	PART NO.	FH19C-***S-0.5SH(99)
	CODE NO.	CL580
		6/7

2. When opening a actuator that is in its locked state (FPC is inserted), take special care not to apply excessive force. Inserting a fingernail or pair of tweezers deeply, as shown in the figure below, may result in deformed terminals.

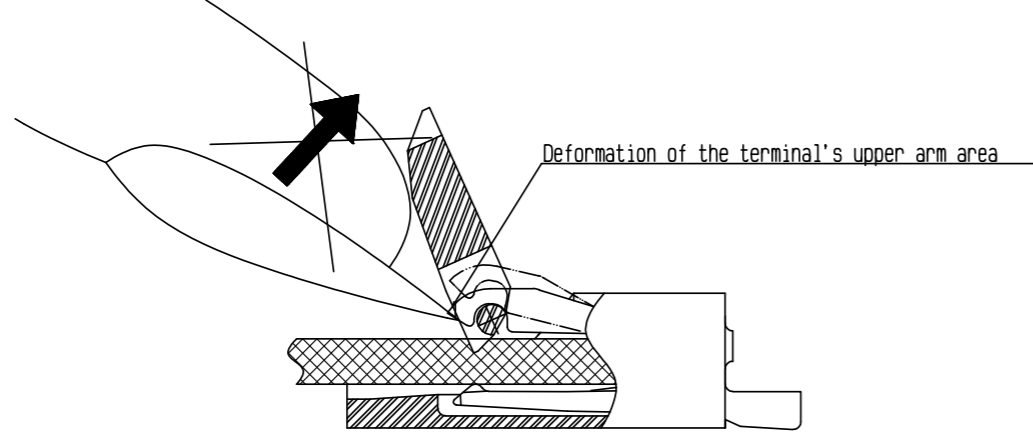

[Reminders on removing the FPC]

◆ To remove the FPC, always make sure that the actuator has been fully released. Do not pull the FPC straight up or at an angle while it is still in the connector. This may cause the upper arm area of the terminal to deform and cause contact failure. To remove the FPC, pull the FPC parallel to the board until it is fully removed from the connector as shown in the figure below.

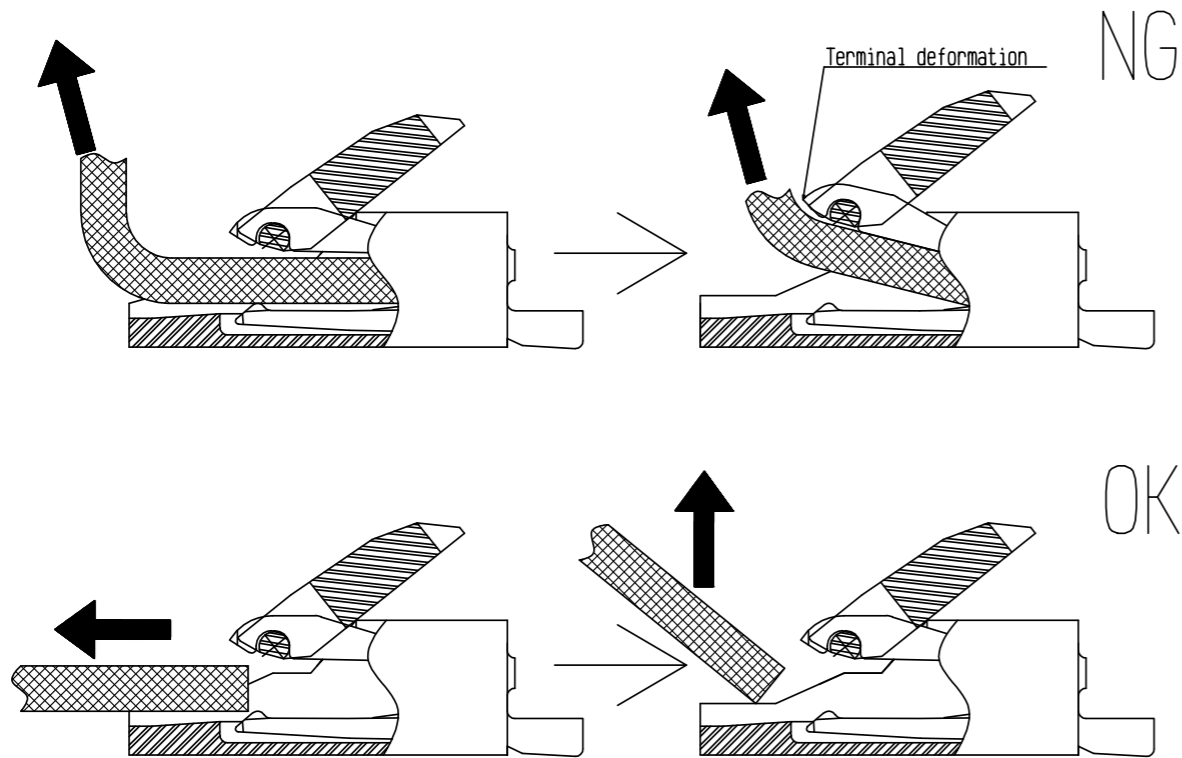

[Other reminders]

◆ Reminders on manual soldering

1. Do not perform reflows or manual soldering with an FPC inserted in the connector.
2. Do not apply excessive heat or allow the soldering iron to touch areas other than the connector's leads. This can cause the connector to deform or melt.
3. Do not use excessive solder (flux).
When too much solder (flux) is used, it can attach to the contacts or the actuator's rotation shaft and cause contact failure or faulty actuator rotation. Additionally, make sure not to use excessive solder on the reinforcement hardware. This may interfere with the actuator's rotation and cause connector damage.

<INSTRUCTION MANUAL>

HRS	DRAWING NO.	EDC-155218-99-00	7/7
	PART NO.	FH19C-***S-0.5SH(99)	
	CODE NO.	CL580	