

REVISIONS			
REV	DESCRIPTION, ECN, EAR NO.	DATE	APP'D
E	PROPOSAL DRAWING	JUN07/13	S.M.
F	PROPOSAL DRAWING	JUN25/13	A.G.
G	SOCKET DEPTH AND TOLERANCE	SEP09/13	S.M.

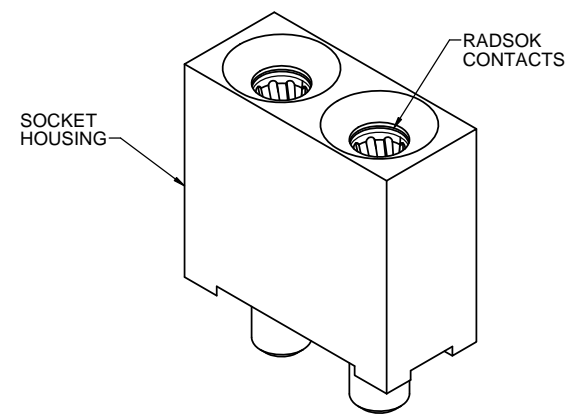

P/N DWR-P1S-B7200-1A5

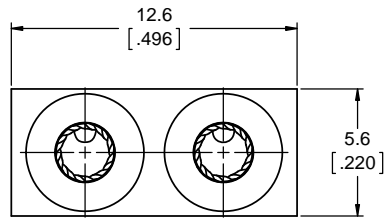
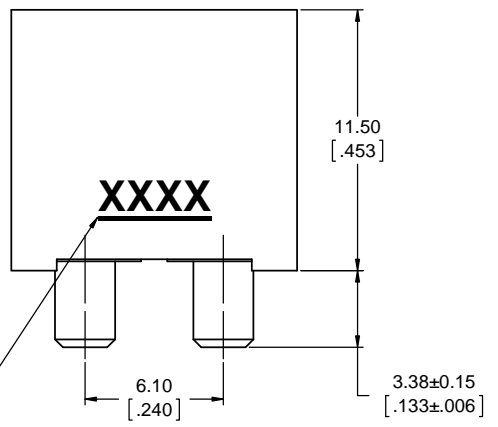

DATE CODE MARKED ON SIDE OF PARTS

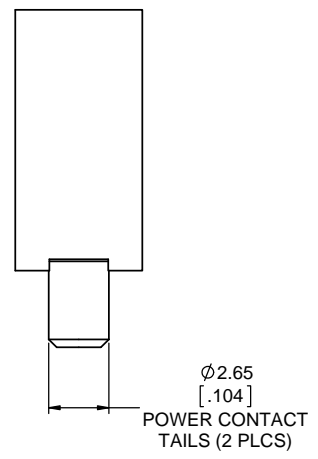

NOTES:

- MATERIALS: ALL MATERIALS ARE RoHS COMPLIANT PER EU DIRECTIVE 2011/65/EU AND AMENDMENTS.**
 - HOUSING: HIGH TEMPERATURE GLASS FILLED NYLON, UL FLAMMABILITY RATING 94V-0, COLOUR BLACK
 - POWER CONTACTS: COPPER ALLOY PLATED WITH 5.08µm (200µ") SILVER OVER 1.27µm (50µ") MIN NICKEL.
- ELECTRICAL CHARACTERISTICS:**
 - CURRENT RATING: 35A PER CONTACT
 - OPERATING TEMPERATURE: -55°C TO +105°C
 - DIELECTRIC WITHSTANDING VOLTAGE: 1500VDC
 - INSULATION RESISTANCE: 5000 MEGOHMS



UNLESS SPECIFIED OTHERWISE	DRAWN	A.ESPIE	MAY08/13
PRIMARY UNITS MILLIMETERS	CHECKED	S.MUGAN	MAY08/13
SECONDARY UNITS INCHES	M.E. APP'D		
REFERENCE IN PARENTHESES	Q.A. APP'D		
GENERAL TOLERANCES	DWG APPR.		
1 DECIMAL PLACE ±0.25	ENG. REL. NO.		
2 DECIMAL PLACES ±0.10	REF.		
3 DECIMAL PLACES	THIRD ANGLE PROJECTION	DO NOT SCALE DRAWING	
ANGULAR DEGREES			

Amphenol Canada Corp.
www.amphenolcanada.com

DWR SERIES SLIM DRAWER, 2 POWER COMPACT SOCKET CONNECTOR, 2.4mm RADSOK, PCB TAIL TERMINATION, RoHS COMPLIANT

DWG. NO. **P-DWR-P1S-B7200-1A5** REV **G**

CODE ID NO. 03554 DWG SIZE: X SCALE: 6:1 SHEET 1 OF 2

REVISIONS			
REV	DESCRIPTION, ECN, EAR NO.	DATE	APP'D
E	PROPOSAL DRAWING	JUN07/13	S.M.
F	PROPOSAL DRAWING	JUN25/13	A.G.
G	SOCKET DEPTH AND TOLERANCE	SEP09/13	S.M.

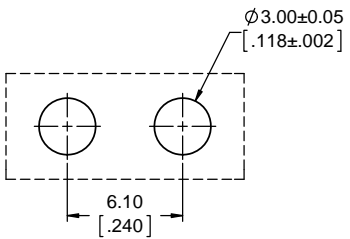

RECOMMENDED PCB LAYOUT
(COMPONENT SIDE OF BOARD)
SCALE 5:1

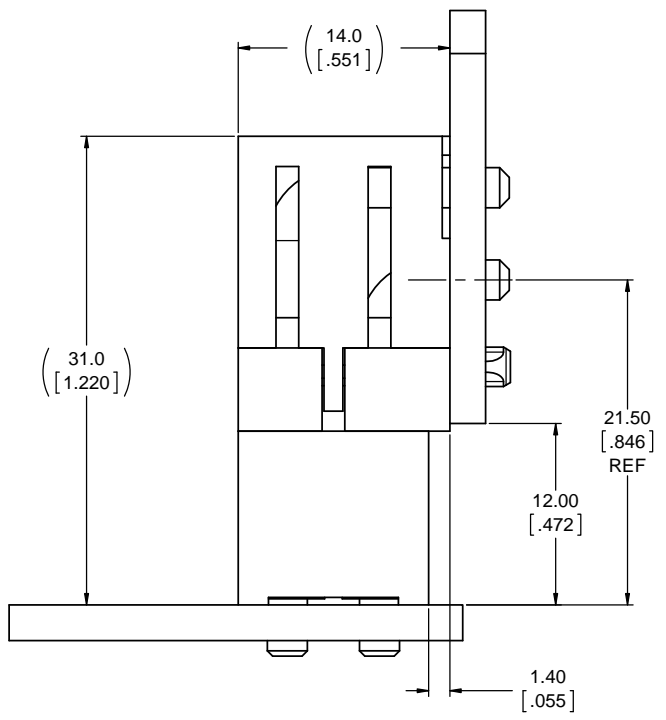
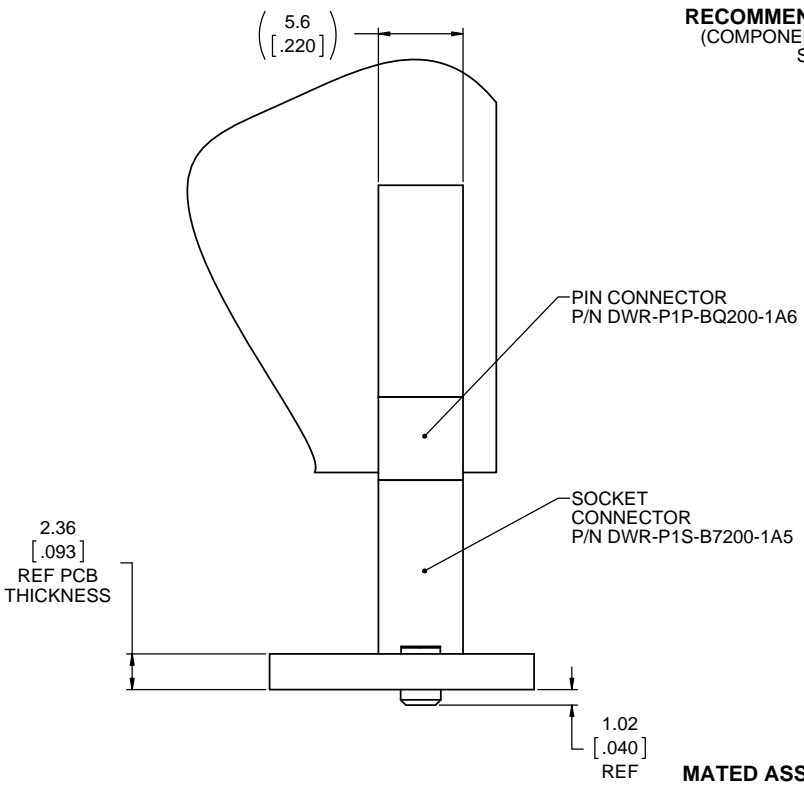

MATED ASSEMBLY



UNLESS SPECIFIED OTHERWISE	DRAWN	A.ESPIE	MAY08/13
PRIMARY UNITS MILLIMETERS	CHECKED	S.MUGAN	MAY08/13
SECONDARY UNITS INCHES	M.E. APP'D		
REFERENCE IN PARENTHESES	Q.A. APP'D		
GENERAL TOLERANCES	DWG APPR.		
1 DECIMAL PLACE	ENG. REL. NO.		
2 DECIMAL PLACES ± 0.20	REF.		
3 DECIMAL PLACES	THIRD ANGLE PROJECTION		
ANGULAR DEGREES	DO NOT SCALE DRAWING		

Amphenol Canada Corp.
www.amphenolcanada.com

DWR SERIES SLIM DRAWER, 2 POWER COMPACT SOCKET CONNECTOR, 2.4mm RADSOK, PCB TAIL TERMINATION, RoHS COMPLIANT

DWG. NO. **P-DWR-P1S-B7200-1A5** REV **G**

CODE ID NO. 03554 DWG SIZE: X SCALE: 4:1 SHEET 2 OF 2