

THIS DRAWING IS UNPUBLISHED. VERTRÄULICHE UNVERÖFFENTLICHTE ZEICHNUNG. RELEASED FOR PUBLICATION. FREI FUER VERÖFFENTLICHUNG. 2016. MATED WITH. PASSEND ZU: COPYRIGHT 2013 BY TE Connectivity. ALL RIGHTS RESERVED. ALLE RECHTE VORBEHALTEN.

PROJEKT NR.: PRJ-13-000001662

P	LTR	DESCRIPTION BESCHREIBUNG	DATE	DWN	APVD
	A1	RELEASE FOR PRODUCTION	04AUG2016	SH	MS

MOUNTED STATE - FOR INFORMATION ONLY

MONTIERTER ZUSTAND - NUR ZUR INFORMATION

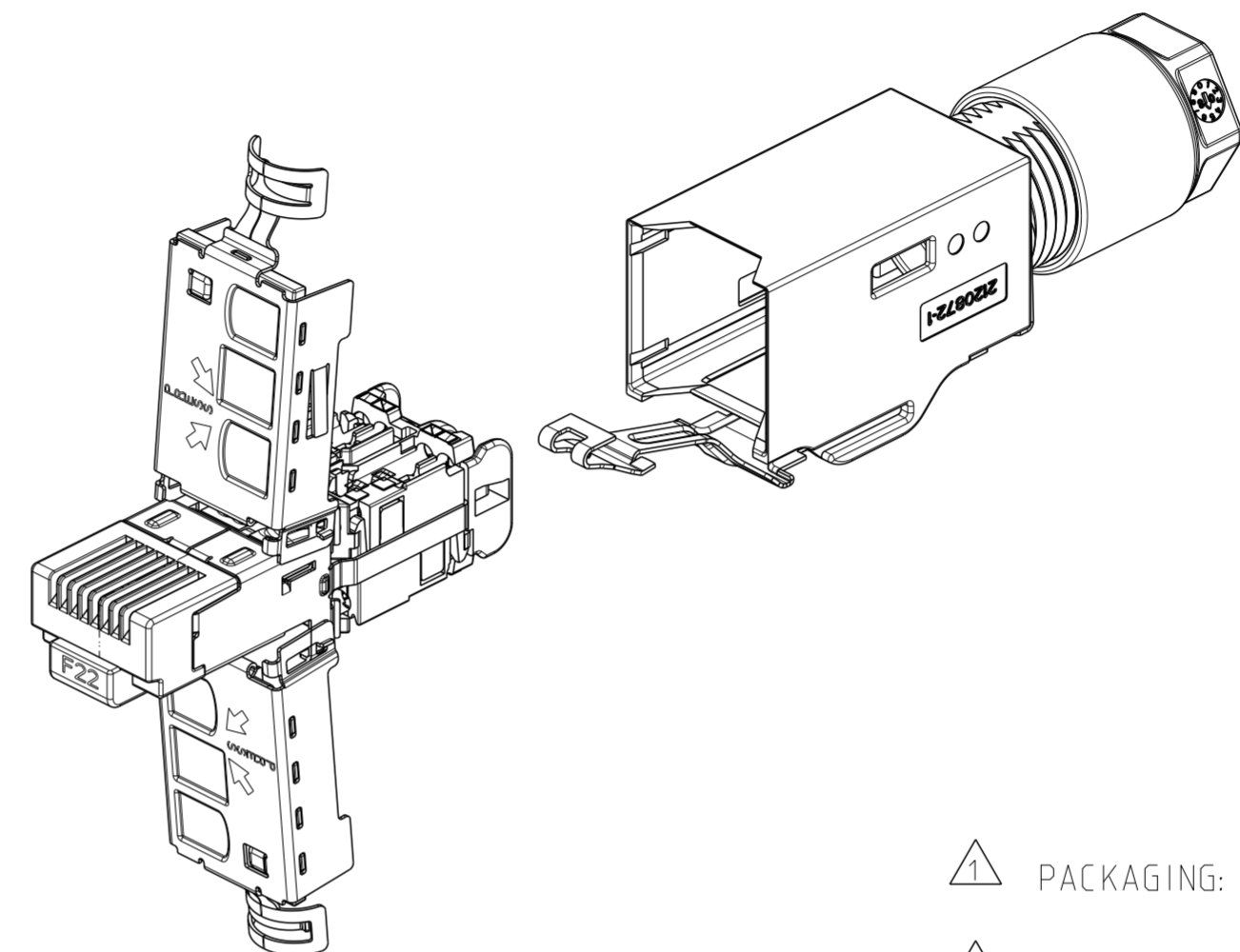
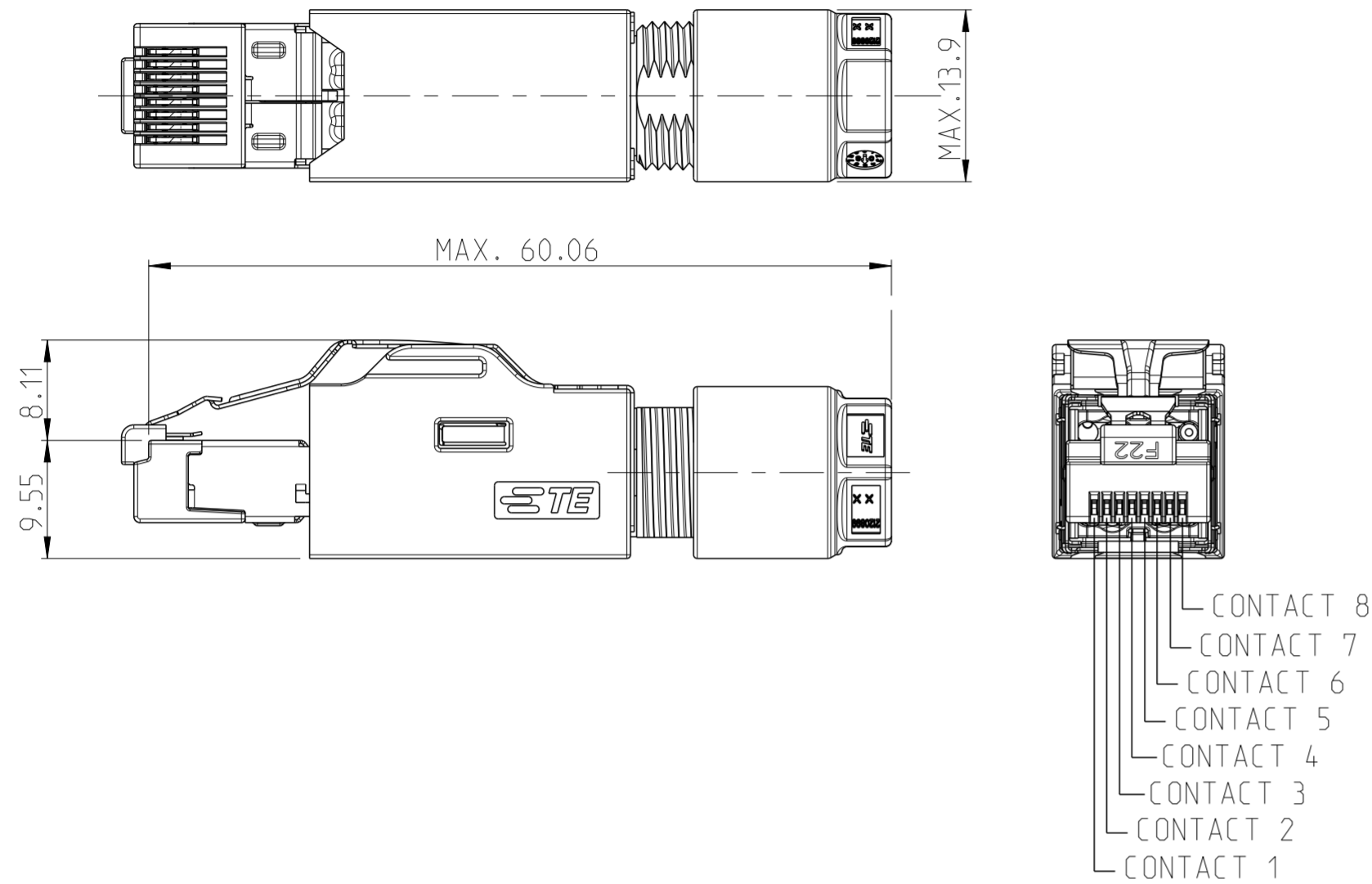

1 PACKAGING: PACKAGING SPEC. 107-18109

1 VERPACKUNG: VERPACKUNGS SPEC. 107-18109

CABLE: 8 POS. AWG 24 STRANDED OR SOLID

KABEL: 8 POL. AWG 24 LITZE ODER MASSIV

RECOMMENDED STRIPPING LENGTH

EMPFOHLENE ABISOLIERLÄNGE

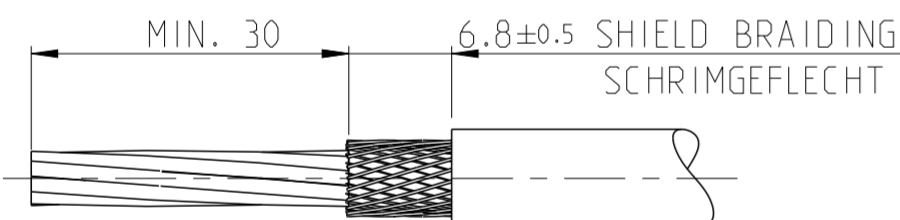

COLOR ALLOCATION OF TERMINAL WIRE TO RJ45 CONTACT 8 POS. TYPE:

FARBZUORDNUNG DES ANSCHLUSSDRAHTES ZUM RJ45-KONTAKT 8 POL. AUSFÜHRUNG:

CONTACT NO./NR.	WIRE COLOR DRAHTFARBE
1	WHITE/GREEN WEISS/GRÜN
2	GREEN GRÜN
3	WHITE/ORANGE WEISS/ORANGE
4	BLUE BLAU
5	WHITE/BLUE WEISS/BLAU
6	ORANGE ORANGE
7	WHITE/BROWN WEISS/BRAUN
8	BROWN BRAUN

PRODUCTION DATE CODE FERTIGUNGSDATUM		
YEAR/JAHR	CODE	WEEK/WOCHE
2015	F	01
2016	H	T0
2017	J	52
2018	K	
2019	L	
2020	M	
EXAMPLES: BEISPIELE:	WEEK 22 IN 2015 = F22	
	WEEK 3 IN 2018 = K03	

SINGLE-PACKAGING EINZEL-VERPACKUNG 1:2

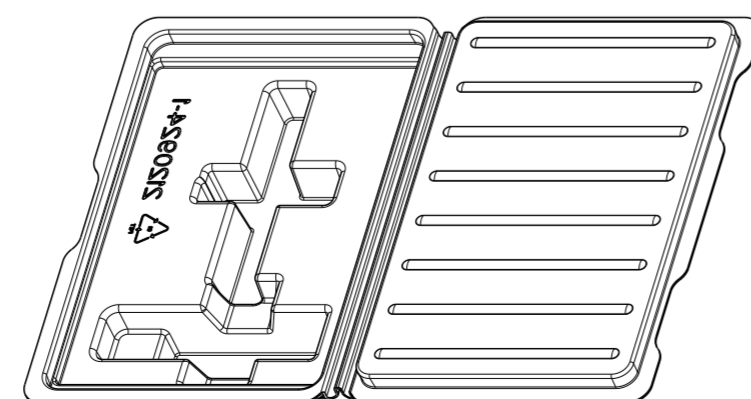

TE ORDER-NO. BESTELL-NR.

2120892-3	2120892-2	2120892-1	1	1	RJ45 CONNECTOR CAT6A, IP20 PLUG PACKED WITH INSTRUCTION SHEET RJ45 STECKVERBINDER CAT6A, IP20 STECKER VERPACKT MIT VERARBEITUNGSANWEISUNG	BLACK SCHWARZ Au OVER PdNi	LCP-GF30 LCP-GF30 STAINLESS STEEL COPPER ALLOY
QUANTITY STÜCK	ITEM-NO. POS.	DESCRIPTION BENENNUNG	SURFACE OBERFLÄCHE		MATERIAL		
					COLOUR/FARBE		

-1 AS SHOWN
WIE GEZEICHNET

THIS DRAWING IS A CONTROLLED DOCUMENT. DIMENSIONING AND TOLERANCING PER GPS (ISO STANDARDS).

DIMENSIONS: MASSEINHEITEN: (MM)	TOLERANCES UNLESS OTHERWISE SPECIFIED: ALLGEMEINTOLERANZEN
0 PLC	±0.3
1 PLC	±0.3
2 PLC	±0.3
3 PLC	±
4 PLC	±
ANGLES/WINKEL	±
FINISH/OBERFLÄCHE/FARBE	-

DWN	260CT2013	CHK	260CT2013	APVD	260CT2013	NAME	RJ45 CONNECTOR CAT6A, IP20 PLUG RJ45 STECKVERBINDER CAT6A, IP20 STECKER
E. REISS		M. STRELOW		C. SCHRETTLINGER			
PRODUCT SPEC	108-94413	APPLICATION SPEC	411-18570	WEIGHT	15g	SIZE	A2
CUSTOMER DRAWING	/KUNDENZEICHNUNG	SCALE	1:2	SHEET	1 OF 1	REV	A1

SIZE ISO 14405 (E)