

ISS.	AMEND	DATE
1	ISSUED	24/11/2011

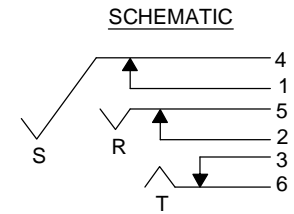

SWITCH CONTACTS OPEN WHEN PLUG IS INSERTED, CLOSE WHEN PLUG IS WITHDRAWN.

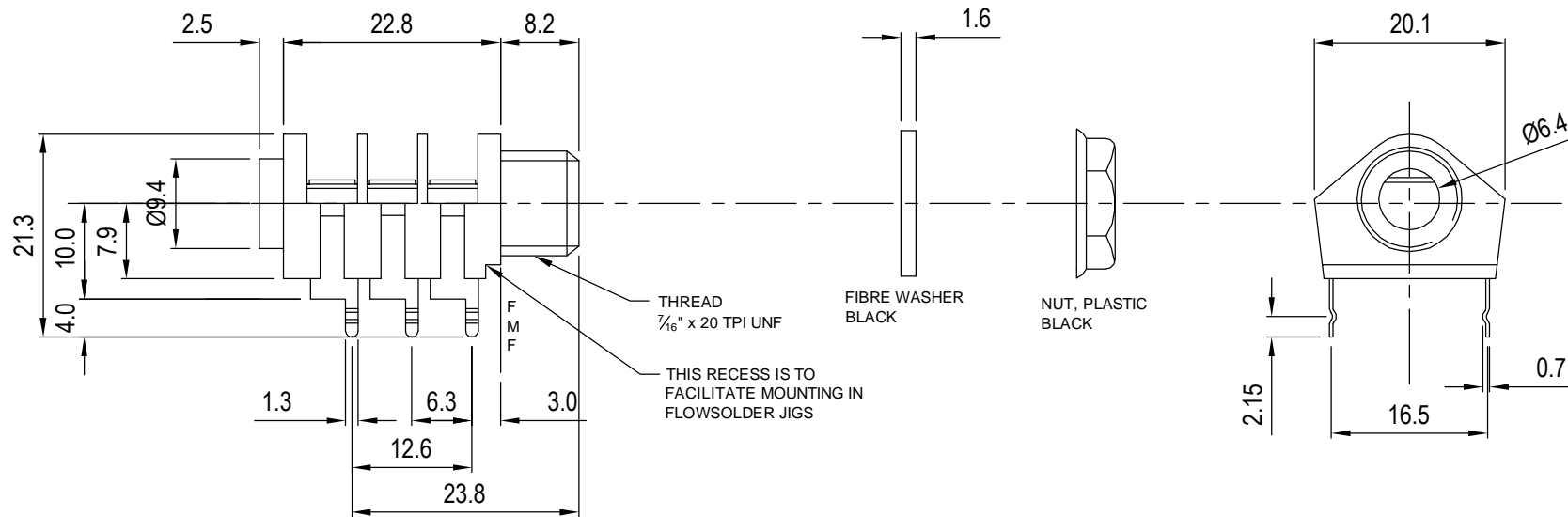
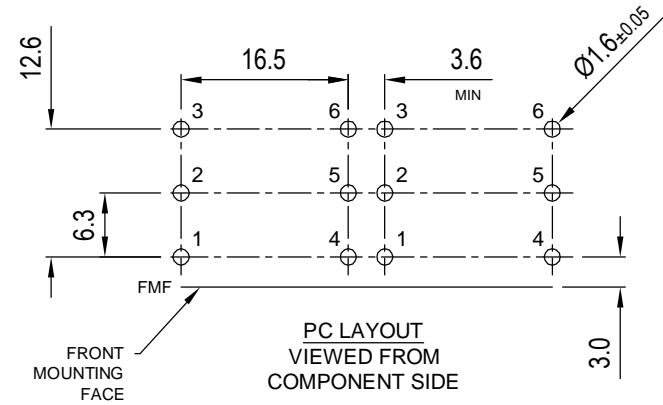

NOTES:-

1. MAXIMUM PANEL THICKNESS 4.6mm.
2. SUPPLIED WITH NUT & WASHER UNASSEMBLED.

RoHS
COMPLIANT

TOLERANCE
NO DEC. PLACE ±
1 DEC. PLACE ±
2 DEC. PLACE ±
HOLE Ø ±
ANGLES ±
UNLESS OTHERWISE STATED

1ST DRAWN : 11/01/1991

3rd ANGLE PROJECTION:

DO NOT SCALE

Cliff Electronic Components Ltd.
76 Holmethorpe Avenue, Holmethorpe Industrial Estate,
Redhill, Surrey, RH1 2PF, England, UK
Tel: 01737-771375 Fax: 01737-766012 Website: www.cliffuk.co.uk

DIMENSIONS IN MILLIMETERS UNLESS OTHERWISE STATED. WORK TO DIMENSIONS. REMOVE ALL BURRS. IF IN DOUBT ASK.

MATERIAL: NYLON / NiAg / FIBRE

TITLE: S2/BBB/PCA-KINKED JACK SOCKET

FINISH: AS MOULDED / MICROFINISH

DRAWN: NJB

APPROVED: RWT

DRWG. No. **CL 12321K**

FORM: A4DRWGH