

THIS COPY IS PROVIDED ON A RESTRICTED BASIS AND IS NOT TO BE USED IN ANY WAY DETRIMENTAL TO THE INTERESTS OF PANDUIT CORP.

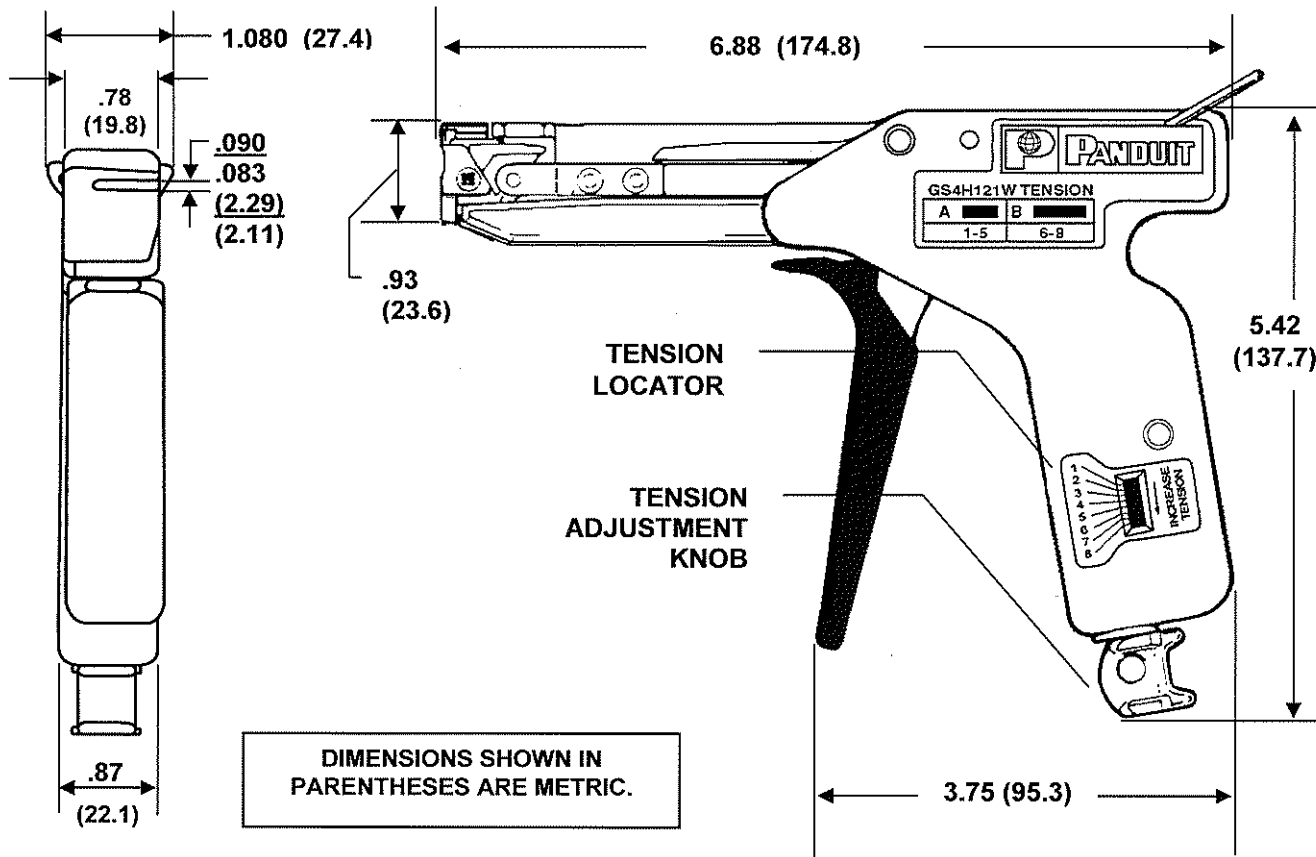

SPECIFICATIONS:

PANDUIT TOOL NO.: GS4H121W
 TOOL WEIGHT: 16 oz. (454 gr.)

INSTALLS LIGHT-HEAVY AND HEAVY
 CROSS SECTION CABLE TIES.

CABLE TIE CROSS SECTION CODE:
 LH = LIGHT HEAVY
 H = HEAVY

- THIS TOOL TIGHTENS CABLE TIES AND CUTS OFF EXCESS PORTION WHEN PRESET TENSION IS ATTAINED.
- SUPPLIED WITH SELECTOR KNOB FOR TENSION ADJUSTMENT.

REFERENCE:

K4H-BLD: Blade Replacement Kit
 TTLK3: Tension Locking Kit

F:/RVUSERS/ENGDOCS/CUSTDWGS/
 WH26859A01_00.doc

										PANDUIT CORP. TINLEY PARK, ILLINOIS					
										GS4H121W CUSTOMER DRAWING					
										UNLESS OTHERWISE SPECIFIED, DIMENSIONAL TOLERANCES ARE: (.x) ± — (.xxx) ± — (.xx) ± — ANGLES ± —		UNLESS OTHERWISE SPECIFIED, ALL DIMENSIONS ARE GIVEN IN INCHES, THIRD ANGLE PROJECTION.			
										DRAWN BY: BLR		MATL: CUSTOMER DRAWING		SCALE NONE	
										DATE: 10-05-11		DRAWING NO. WH26859A01		DWG A SIZE	
00	10-05-11	BLR	ABJ	RELEASED	4409	--	<i>[Signature]</i>			CHK'D: <i>[Signature]</i>					
REV	DATE	BY	CHK'D	DESCRIPTION	ECN	-R	CUST	SUP							