

PART NAME: HANDLE

SCALE: 1:1

DATE: 12/7/16

DR. BY: JAM



P/N: 4571BG

THIS DRAWING IS THE PROPERTY OF DAVIES MOLDING COMPANY, IS SUBMITTED SOLELY AS A DESIGN OR ENGINEERING PROJECT WE ACCEPT NO RESPONSIBILITY WHATSOEVER FOR THE PRACTICAL APPLICATION OF THE PIECES MADE TO THIS DESIGN.

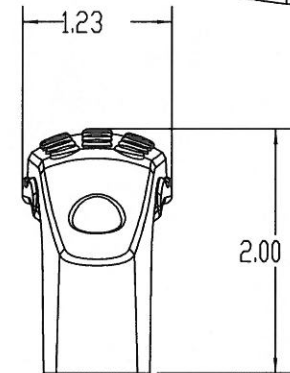
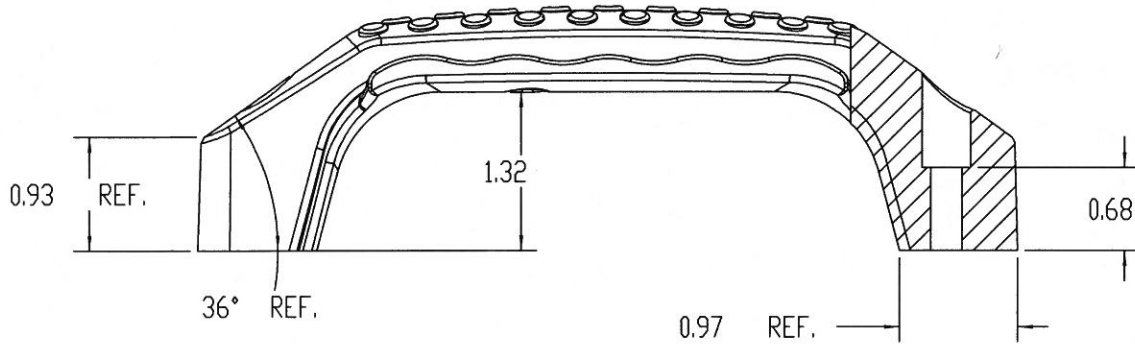
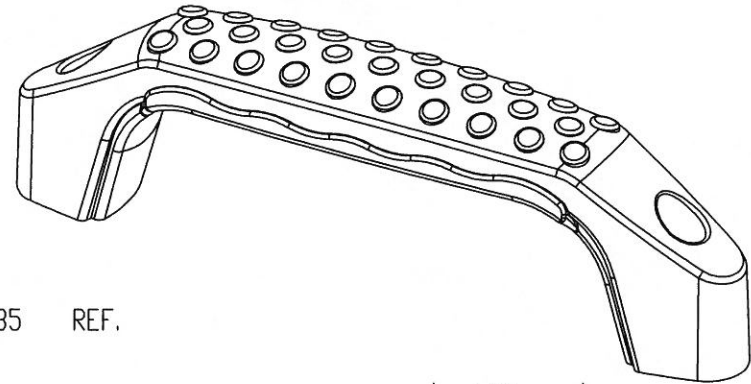
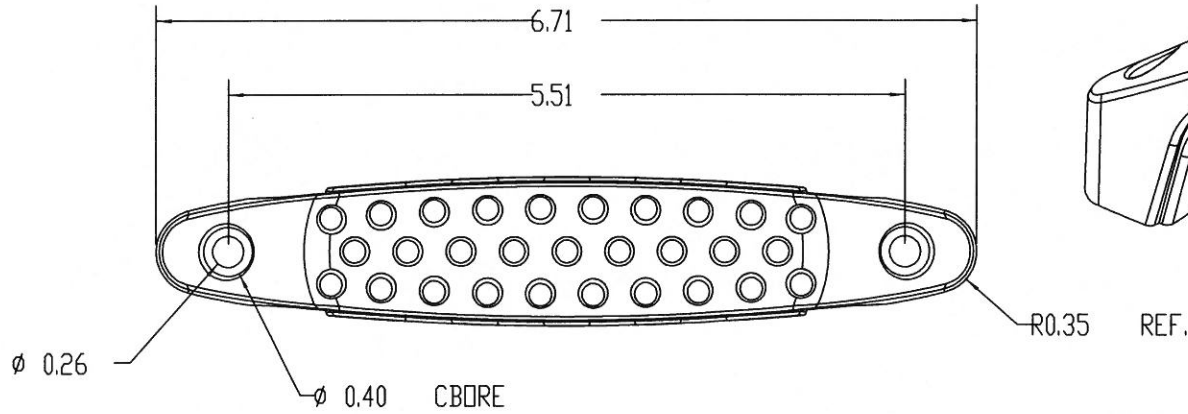

SUBSTRATE MATERIAL: 33% GLASS FILLED NYLON
COLOR: BLACK

OVERMOLD MATERIAL: TPE
COLOR: GRAY

TOLERANCES: UNLESS OTHERWISE SPECIFIED	DO NOT SCALE DRAWING			
DECIMALS: X.XXX ± .005 X.XX ± .015	MM: X.XX ± 0.15MM X.X ± 0.4MM			
FRACTIONS ± 1/64	ANG. ± 1°	CHANGES		