

No OF POSITIONS (PER ROW)
 -010, -011, -013, -020, -025, -030, -037
 -040, -049, -050, *-053, -060, -070, -075,
 *-053 MATES WITH ERCDA

LEAD STYLE
 -01: 1.58 [0.062] BOARD
 -03: 2.36 [0.093] BOARD

PLATING SPECIFICATION
 -S: 30µ" SELECTIVE GOLD IN CONTACT AREA,
 MATTE TIN ON TAIL
 (USE C-231-02-S, C-231-03-S)
 -L: 10µ" SELECTIVE GOLD IN CONTACT AREA,
 MATTE TIN ON TAIL
 (USE C-231-02-L, C-231-03-L)

OPTION
 -TR: TAPE & REEL
 (STANDARD PACKAGING)
 (SEE NOTE 4)

OPTION
 -L: LATCHES (SEE FIG 2, SHT 2)
 -EGP: EXTENDED GUIDE POSTS
 (NOT AVAILABLE WITH -L OPTION)
 (SEE NOTE 9)

-RA: RIGHT ANGLE

ROW SPECIFICATION
 -D: DOUBLE (USE ERF8-XXX-01-D-RA)

** NOT RELEASED FOR PRODUCTION

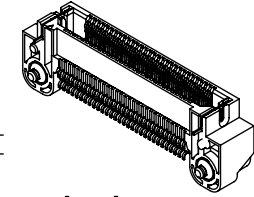
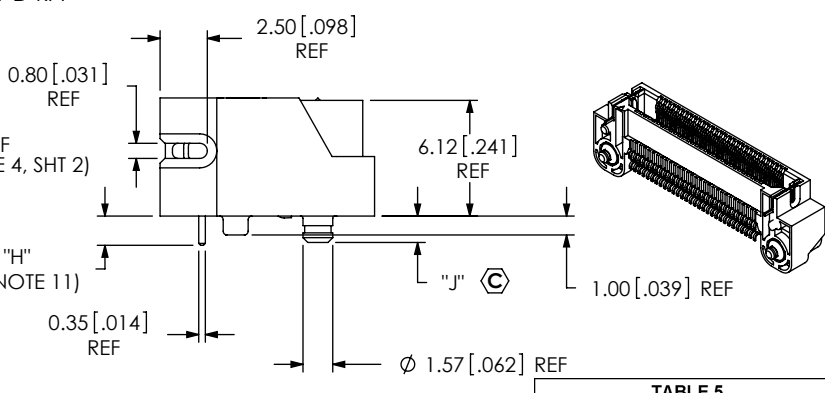
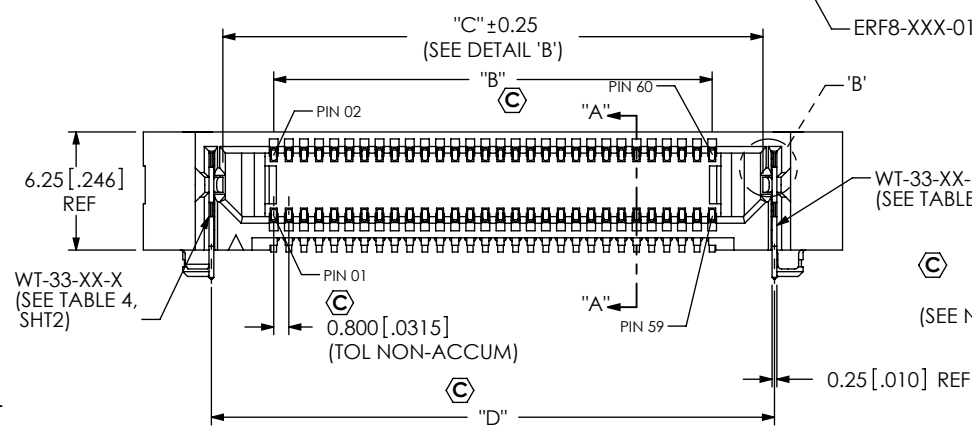

FIG 1
 ERF8-030-01-X-D-RA SHOWN

TABLE 5

LEAD STYLE	"H"	"J"
-01	1.55 [0.061]	1.40 [0.055]
-03	2.34 [0.092]	2.19 [0.086]

NOTES:

- Ⓢ REPRESENTS A CRITICAL DIMENSION.
- MAXIMUM BURR ALLOWANCE: 0.02[0.001]
- MINIMUM PUSHOUT /PULLOUT FORCE: SIGNAL: 2.22 N [0.5 LB.], LATCH AND COUNTERWEIGHT: 4.45 N [1.0 LB.]
- FOR QUANTITIES UP TO 49 PIECES, NO LEADER, TRAILER, OR EIA-481-D REEL WILL BE SUPPLIED. FOR QUANTITIES FROM 50-124 PIECES, NO LEADER OR TRAILER WILL BE SUPPLIED.
- MEASURE AT BEND TANGENCY.
- MEASURED ON PINS ONLY, INSULATOR NOT INCLUDED IN MEASUREMENT.
- ALL DIMENSIONS SYMMETRIC ABOUT C EXCEPT AS SHOWN.
- DELETED
- BOTH NON AND -EGP OPTION PARTS ARE IDENTICAL, THUS INTERCHANGEABLE
- DIMENSIONS MUST BE MEASURED BOTH ENDS OF COMB OR CONNECTOR.
- USE -Z- DATUM ZONE FOR MEASUREMENTS ONLY.
- SEE PTL SYSTEM FOR REQUIRED INSPECTION FIXTURE TO CHECK TAIL CRITICALS.

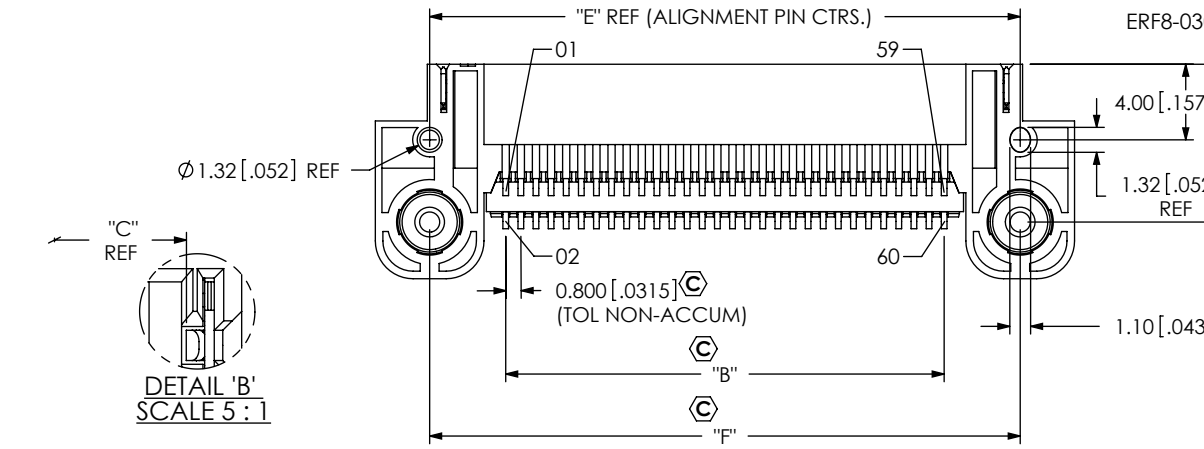

TABLE 1

POSITION	"A"	"B"	"C"	"D"	"E"	"F"	"K"
-010	21.00 [0.827]	7.20 [0.283]	12.54 [0.494]	13.80 [0.543]	15.25 [0.600]	15.25 [0.600]	15.5 [0.61]
-011	21.80 [0.858]	8.00 [0.315]	13.34 [0.525]	14.60 [0.575]	16.05 [0.632]	16.05 [0.632]	16.3 [0.64]
-013	23.40 [0.921]	9.60 [0.378]	14.94 [0.588]	16.20 [0.638]	17.65 [0.695]	17.65 [0.695]	17.9 [0.70]
-020	29.00 [1.142]	15.20 [0.598]	20.54 [0.809]	21.80 [0.858]	23.25 [0.915]	23.25 [0.915]	23.5 [0.93]
-025	33.00 [1.299]	19.20 [0.758]	24.54 [0.966]	25.80 [1.016]	27.25 [1.073]	27.25 [1.073]	27.5 [1.08]
-030	37.00 [1.457]	23.20 [0.913]	28.54 [1.124]	29.80 [1.173]	31.25 [1.230]	31.25 [1.230]	31.5 [1.24]
-037	42.80 [1.677]	28.80 [1.134]	34.14 [1.344]	35.40 [1.394]	36.85 [1.451]	36.85 [1.451]	37.1 [1.46]
-040	45.00 [1.772]	31.20 [1.228]	36.54 [1.439]	37.80 [1.488]	39.25 [1.545]	39.25 [1.545]	39.5 [1.56]
-049	52.20 [2.055]	38.40 [1.512]	43.74 [1.722]	45.00 [1.772]	46.45 [1.829]	46.45 [1.829]	46.7 [1.84]
-050	53.00 [2.087]	39.20 [1.543]	44.54 [1.754]	45.80 [1.803]	47.25 [1.860]	47.25 [1.860]	47.5 [1.87]
*-053	55.40 [2.181]	41.60 [1.638]	46.94 [1.848]	48.20 [1.898]	49.65 [1.955]	49.65 [1.955]	49.9 [1.96]
-060	61.00 [2.402]	47.20 [1.858]	52.54 [2.069]	53.80 [2.118]	55.25 [2.175]	55.25 [2.175]	55.5 [2.19]
-070	69.00 [2.717]	55.20 [2.173]	60.54 [2.383]	61.80 [2.433]	63.25 [2.490]	63.25 [2.490]	63.5 [2.50]
-075	73.00 [2.874]	59.20 [2.331]	64.54 [2.541]	65.80 [2.591]	67.25 [2.648]	67.25 [2.648]	67.5 [2.66]

UNLESS OTHERWISE SPECIFIED,
 DIMENSIONS ARE IN MILLIMETERS [INCHES].
 TOLERANCES ARE:
 DECIMALS ANGLES
 .X: ±0.3 [0.01] 2°
 .XX: ±0.13 [0.005]
 .XXX: ±0.050 [0.0020]

PROPRIETARY NOTE
 THIS DOCUMENT CONTAINS CONFIDENTIAL AND PROPRIETARY INFORMATION AND ALL DESIGN, MANUFACTURING, REPRODUCTION, USE, PATENT RIGHTS AND SALES RIGHTS ARE EXPRESSLY RESERVED BY SAMTEC, INC. THIS DOCUMENT SHALL NOT BE DISCLOSED, IN WHOLE OR PART, TO ANY UNAUTHORIZED PERSON OR ENTITY NOR REPRODUCED, TRANSFERRED OR INCORPORATED IN ANY OTHER PROJECT IN ANY MANNER WITHOUT THE EXPRESS WRITTEN CONSENT OF SAMTEC, INC.

MATERIAL: DO NOT SCALE DRAWING
 INSULATOR: LCP UL94V-0, COLOR BLACK
 CONTACTS: BeCu
 COUNTERWEIGHT: BRASS
 LATCHES: BeCu

SHEET SCALE: 2:1

520 PARK EAST BLVD. NEW ALBANY, IN 47150
 PHONE: 812-944-6733 FAX: 812-948-5047
 e-Mail: info@SAMTEC.com code 55322

DESCRIPTION:
 0.8mm DUAL ROW RIGHT ANGLE SOCKET ASSEMBLY

DWG. NO.
ERF8-XXX-XX-X-D-RA-XXX-TR

OPTION	STYLE	BODY CALLOUT	CONTACTS	COUNTERWEIGHT	WELD TABS
NONE / -EGP (SEE NOTE 9)	-01	ERF8-XXX-01-D-RA	C-231-02-X	T-1R37-01-X	WT-33-05-T
			C-231-03-X		WT-33-06-T
	-03	ERF8-XXX-01-D-RA	C-231-02-X	T-1R37-02-X	WT-33-07-T
			C-231-03-X		WT-33-08-T
-L	-01	ERF8-XXX-01-D-RA	C-231-02-X	T-1R37-01-X	WT-33-01-F
			C-231-03-X		WT-33-02-F
	-03	ERF8-XXX-01-D-RA	C-231-02-X	T-1R37-02-X	WT-33-03-F
			C-231-03-X		WT-33-04-F

POSITION	"G"	
-010	11.14	[.439]
-011	11.94	[.470]
-013	13.54	[.533]
-020	19.14	[.754]
-025	23.14	[.911]
-030	27.14	[1.069]
-037	32.74	[1.289]
-040	35.14	[1.383]
-49	42.34	[1.667]
-050	43.14	[1.698]
**053	45.54	[1.793]
-060	51.14	[2.013]
-070	59.14	[2.328]
-075	63.14	[2.486]

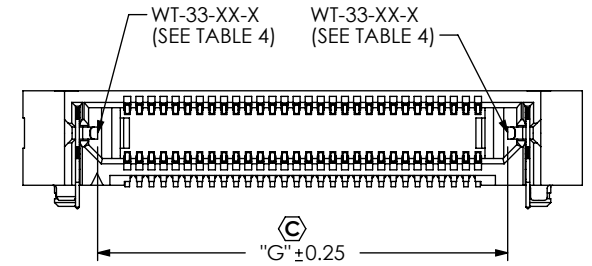
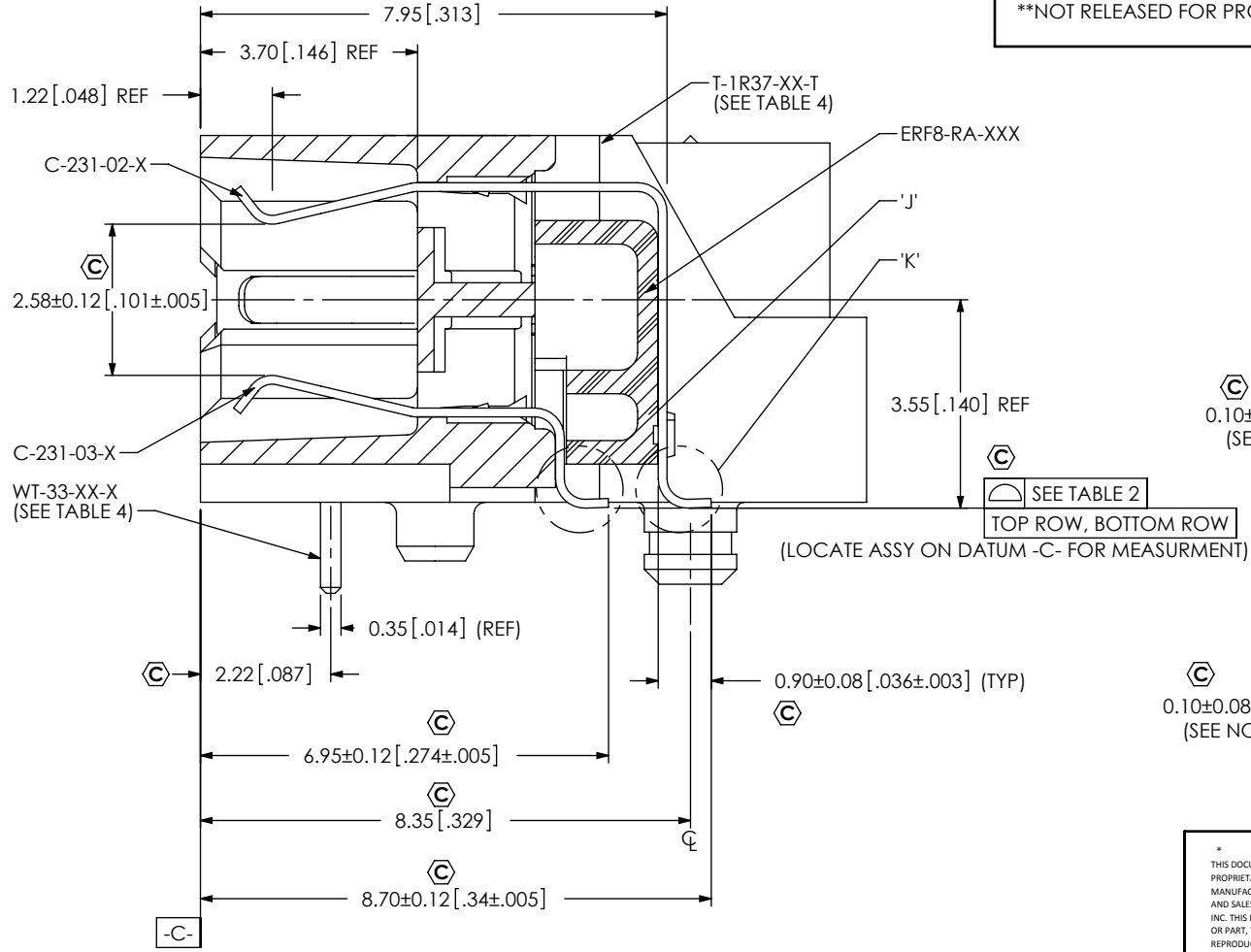

FIG 2
ERF8-030-01-X-D-RA-L SHOWN
(DIFFERENT AS SHOWN, OTHERWISE SAME AS FIG 1)



SECTION "A"-"A"
SCALE 8:1

No OF POSITIONS	BOTTOM ROW STRAIGHTNESS	TOP ROW STRAIGHTNESS	COPLANARITY
-010 THRU **053	0.08 [.003]	0.08 [.003]	0.10 [.004]
-060 THRU -075	0.10 [.004]	0.10 [.004]	0.15 [.006]

** NOT RELEASED FOR PRODUCTION

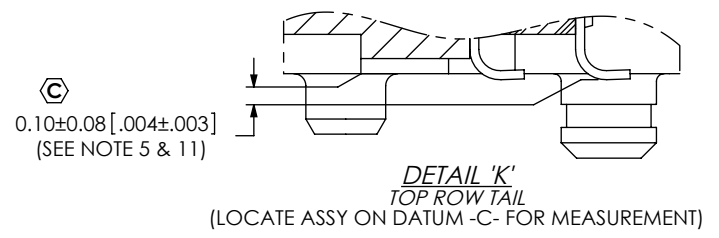
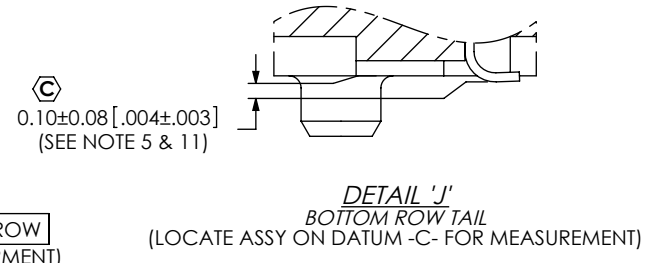

PROPRIETARY NOTE
THIS DOCUMENT CONTAINS CONFIDENTIAL AND PROPRIETARY INFORMATION AND ALL DESIGN, MANUFACTURING, REPRODUCTION, USE, PATENT RIGHTS AND SALES RIGHTS ARE EXPRESSLY RESERVED BY SAMTEC, INC. THIS DOCUMENT SHALL NOT BE DISCLOSED, IN WHOLE OR IN PART, TO ANY UNAUTHORIZED PERSON OR ENTITY NOR REPRODUCED, TRANSFERRED OR INCORPORATED IN ANY OTHER PROJECT IN ANY MANNER WITHOUT THE EXPRESS WRITTEN CONSENT OF SAMTEC, INC.

samtec
520 PARK EAST BLVD. NEW ALBANY, IN 47150
PHONE: 812-944-6733 FAX: 812-948-5047
e-Mail: info@SAMTEC.com code 55322

DO NOT SCALE DRAWING
SHEET SCALE: 6:1

DESCRIPTION:
0.8mm DUAL ROW RIGHT ANGLE SOCKET ASSEMBLY
DWG. NO.
ERF8-XXX-XX-X-D-RA-XXX-TR
BY: D BOYCE 08-10-2010 SHEET 2 OF 6

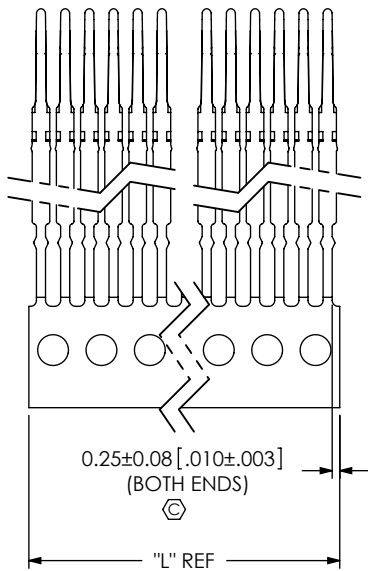
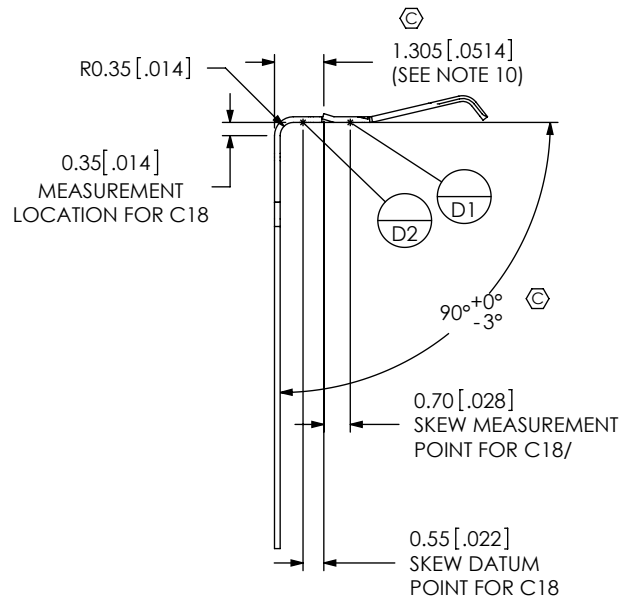

TABLE 6

POSITION	"L"	
-010	8.00	[.315]
-011	8.80	[.3460]
-013	10.10	[.398]
-020	16.00	[.63]
-025	20.00	[.787]
-030	24.00	[.945]
-037	29.60	[1.165]
-040	32.00	[1.26]
-49	39.20	[1.543]
-050	40.00	[1.575]
**-.053	42.40	[1.669]
-060	48.00	[1.89]
-070	56.00	[2.205]
-075	60.00	[2.362]

(** = NOT RELEASE FOR PRODUCTION)

IN PROCESS 1 & 7
(COMB CUT CONTACT
C-231-03-X & C-231-02-X)



IN-PROCESS 2
(FORM 1 CONTACT C-231-03-X)

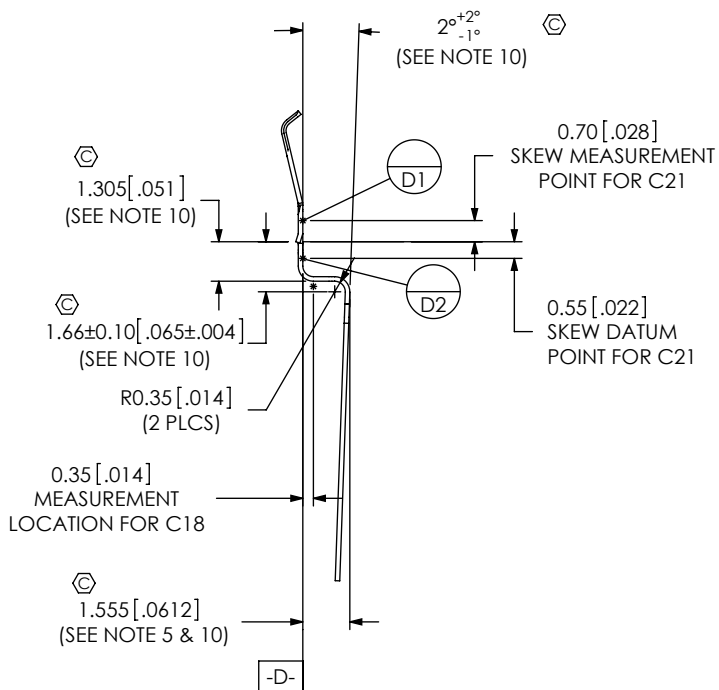

IN-PROCESS 3
(FORM 2 CONTACT C-231-03-X)

F:\DWG\MISC\MKTG\ERF8-XXX-XX-X-D-RA-XXX-TR-MKT.SLDDRW

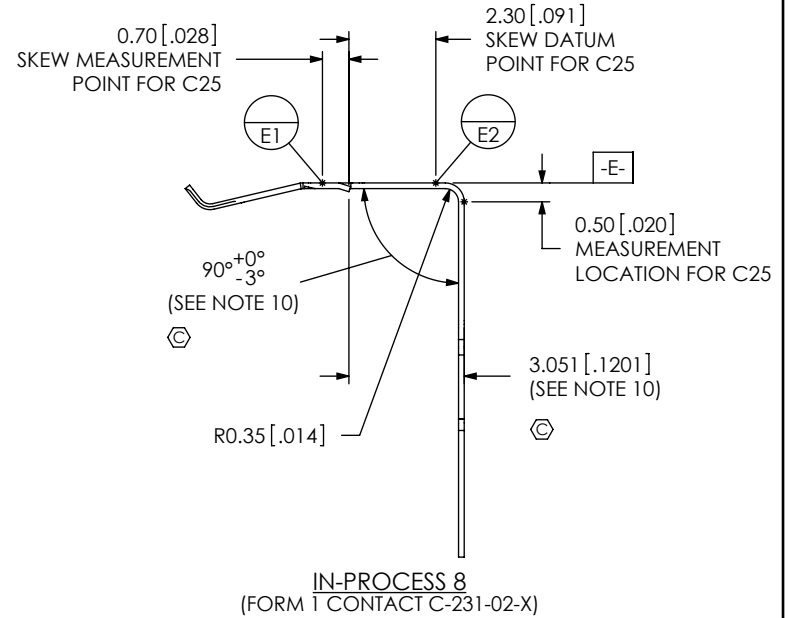

IN-PROCESS 8
(FORM 1 CONTACT C-231-02-X)

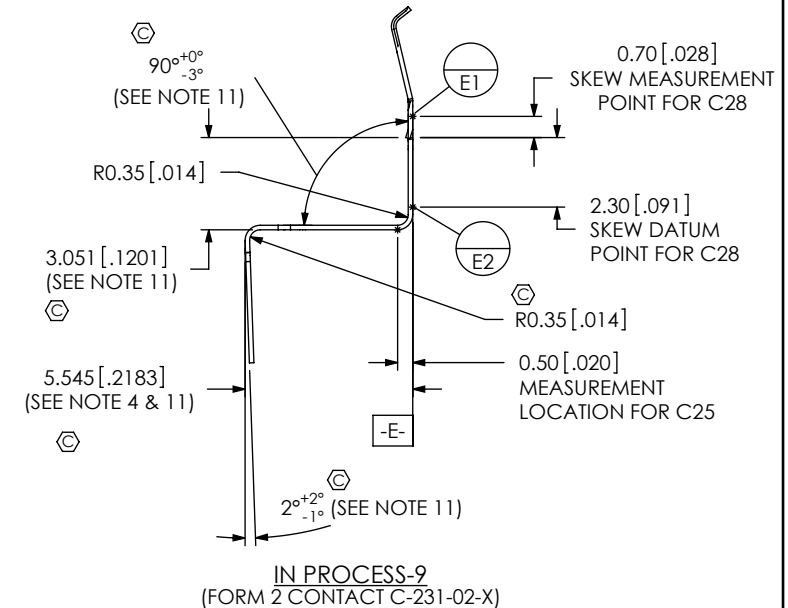

IN-PROCESS 9
(FORM 2 CONTACT C-231-02-X)

PROPRIETARY NOTE
THIS DOCUMENT CONTAINS CONFIDENTIAL AND PROPRIETARY INFORMATION AND ALL DESIGN, MANUFACTURING, REPRODUCTION, USE, PATENT RIGHTS AND SALES RIGHTS ARE EXPRESSLY RESERVED BY SAMTEC, INC. THIS DOCUMENT SHALL NOT BE DISCLOSED, IN WHOLE OR PART, TO ANY UNAUTHORIZED PERSON OR ENTITY NOR REPRODUCED, TRANSFERRED OR INCORPORATED IN ANY OTHER PROJECT IN ANY MANNER WITHOUT THE EXPRESS WRITTEN CONSENT OF SAMTEC, INC.

DO NOT SCALE DRAWING
SHEET SCALE: 4:1



520 PARK EAST BLVD. NEW ALBANY, IN 47150
PHONE: 812-944-6733 FAX: 812-948-5047
e-Mail: info@SAMTEC.com code 55322

DESCRIPTION:
0.8mm DUAL ROW RIGHT ANGLE SOCKET ASSEMBLY
DWG. NO.
ERF8-XXX-XX-X-D-RA-XXX-TR
BY: D BOYCE 08-10-2010 SHEET 3 OF 6

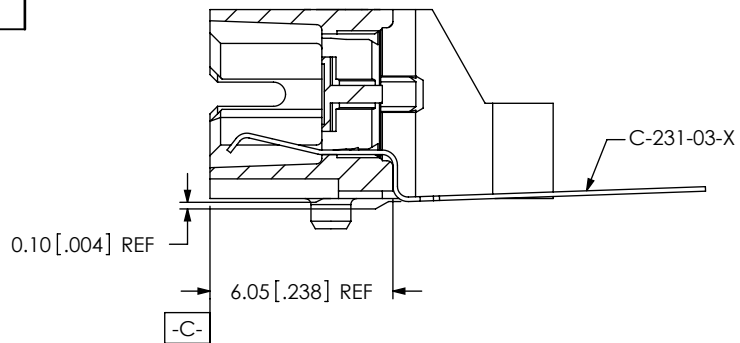

IN-PROCESS 4
(FILL BOTTOM ROW)
(SEE INSPECTION VIEW 1 FOR ASSEMBLY ORIENTATION AND CPC'S)

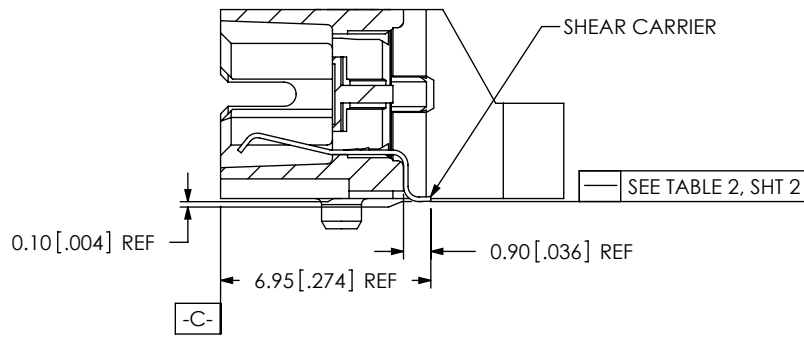

IN-PROCESS 5
(CUTOFF OF CARRIER)
(SEE INSPECTION VIEW 1 FOR ASSEMBLY ORIENTATION AND CPC'S)

INSPECTION VIEW 1
(SEE NOTE 12)

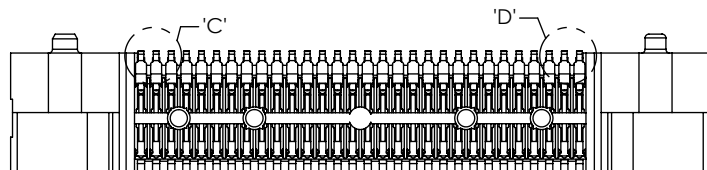
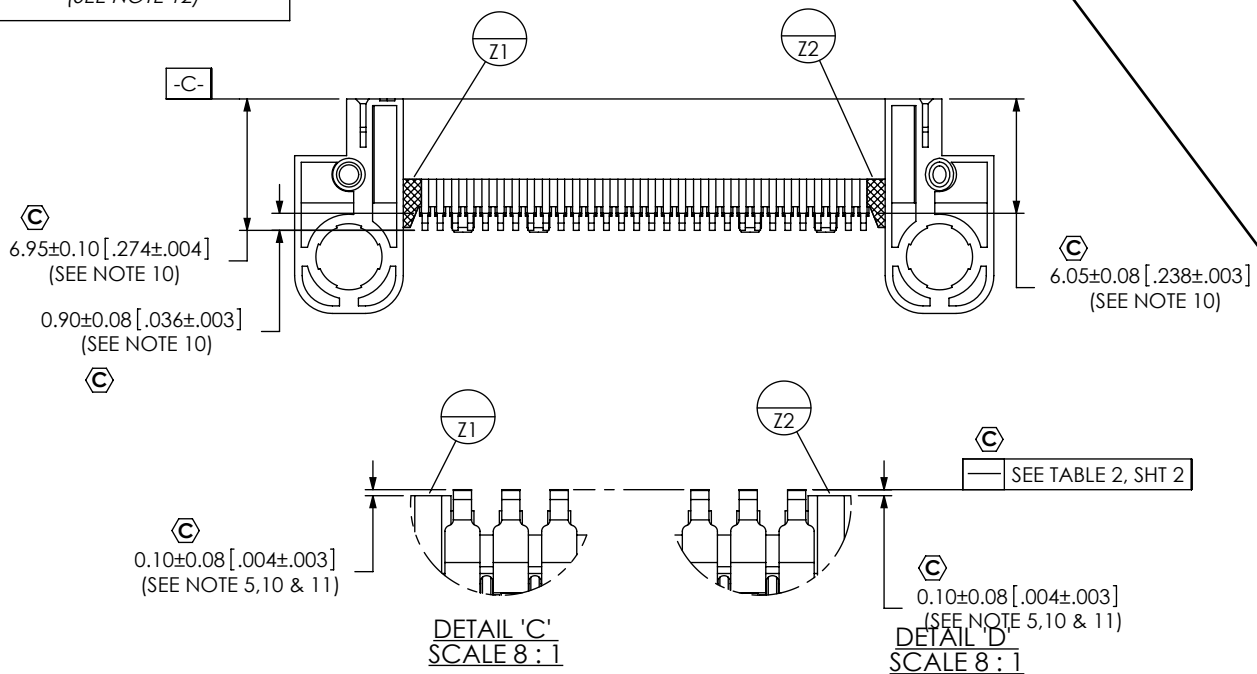

INSPECTION FOR IN-PROCESS 4 & 5
(CARRIER NOT SHOWN FOR IN PROCESS 4 INSPECTIONS)

F:\DWG\MISC\MKTG\ERF8-XXX-XX-X-D-RA-XXX-TR-MKT.SLDDRW

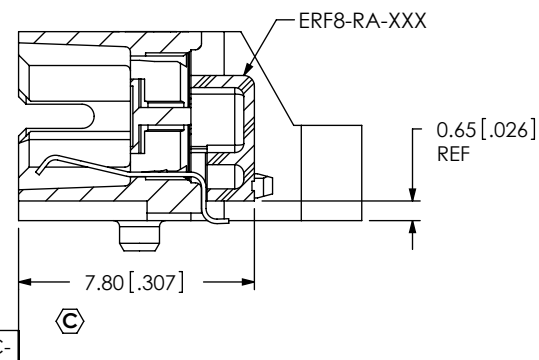

IN-PROCESS 6
(FILL ERF8-RA-XXX)

PROPRIETARY NOTE
THIS DOCUMENT CONTAINS CONFIDENTIAL AND PROPRIETARY INFORMATION AND ALL DESIGN, MANUFACTURING, REPRODUCTION, USE, PATENT RIGHTS AND SALES RIGHTS ARE EXPRESSLY RESERVED BY SAMTEC, INC. THIS DOCUMENT SHALL NOT BE DISCLOSED, IN WHOLE OR PART, TO ANY UNAUTHORIZED PERSON OR ENTITY NOR REPRODUCED, TRANSFERRED OR INCORPORATED IN ANY OTHER PROJECT IN ANY MANNER WITHOUT THE EXPRESS WRITTEN CONSENT OF SAMTEC, INC.

DO NOT SCALE DRAWING
SHEET SCALE: 4:1



520 PARK EAST BLVD, NEW ALBANY, IN 47150
PHONE: 812-944-6733 FAX: 812-948-5047
e-Mail: info@SAMTEC.com code 55322

DESCRIPTION:
0.8mm DUAL ROW RIGHT ANGLE SOCKET ASSEMBLY
DWG. NO.
ERF8-XXX-XX-X-D-RA-XXX-TR
BY: D BOYCE 08-10-2010 SHEET 4 OF 6

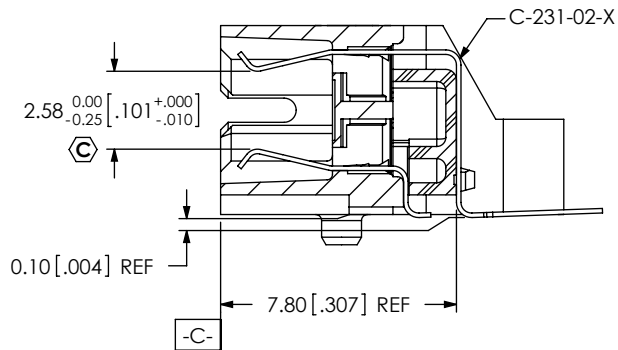

IN-PROCESS 10
(FILL TOP ROW)
(SEE INSPECTION VIEW 2 FOR ASSEMBLY ORIENTATION AND CPC'S)

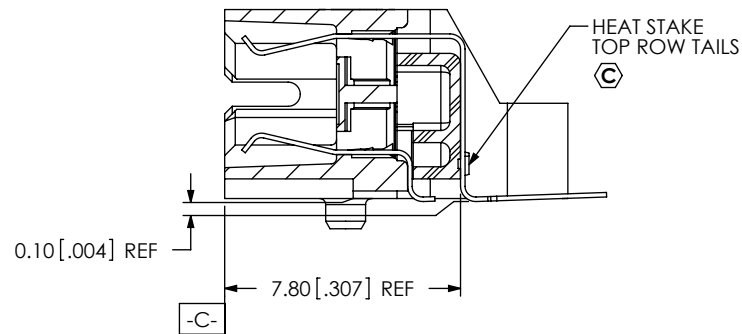

IN-PROCESS 11
(HEAT STAKE TOP ROW CONTACTS)
(SEE INSPECTION VIEW 2 FOR ASSEMBLY ORIENTATION AND CPC'S)

INSPECTION VIEW 2
(SEE NOTE 12)

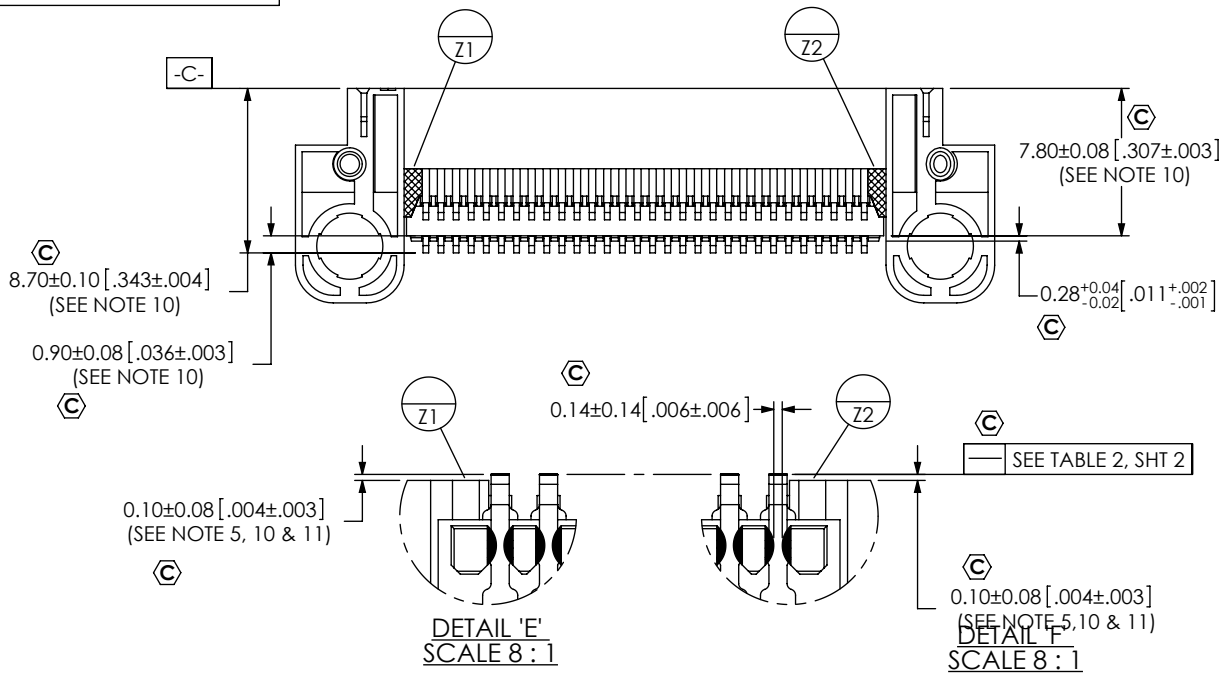

INSPECTION FOR IN-PROCESS 10, 11 & 12
(CARRIER NOT SHOWN FOR IN PROCESS 10 & 11 INSPECTIONS)

F:\DWG\MISC\MKTG\ERF8-XXX-XX-X-D-RA-XXX-TR-MKT.SLDDRW

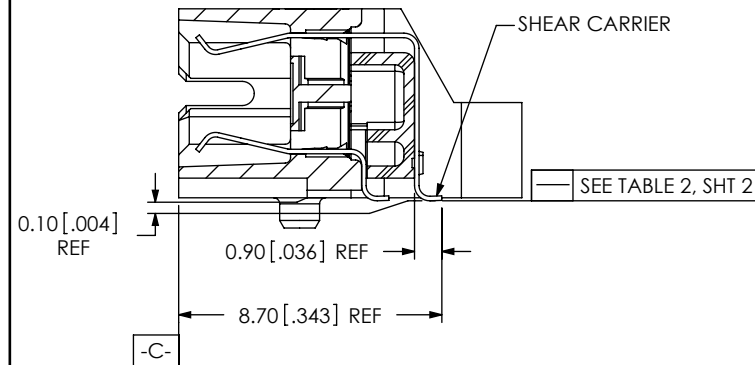

PROPRIETARY NOTE
THIS DOCUMENT CONTAINS CONFIDENTIAL AND PROPRIETARY INFORMATION AND ALL DESIGN, MANUFACTURING, REPRODUCTION, USE, PATENT RIGHTS AND SALES RIGHTS ARE EXPRESSLY RESERVED BY SAMTEC, INC. THIS DOCUMENT SHALL NOT BE DISCLOSED, IN WHOLE OR PART, TO ANY UNAUTHORIZED PERSON OR ENTITY NOR REPRODUCED, TRANSFERRED OR INCORPORATED IN ANY OTHER PROJECT IN ANY MANNER WITHOUT THE EXPRESS WRITTEN CONSENT OF SAMTEC, INC.

DO NOT SCALE DRAWING

SHEET SCALE: 4:1



520 PARK EAST BLVD, NEW ALBANY, IN 47150
PHONE: 812-944-6733 FAX: 812-948-5047
e-Mail info@SAMTEC.com code 55322

DESCRIPTION:
0.8mm DUAL ROW RIGHT ANGLE SOCKET ASSEMBLY

DWG. NO.
ERF8-XXX-XX-X-D-RA-XXX-TR

BY: D BOYCE 08-10-2010 SHEET 5 OF 6

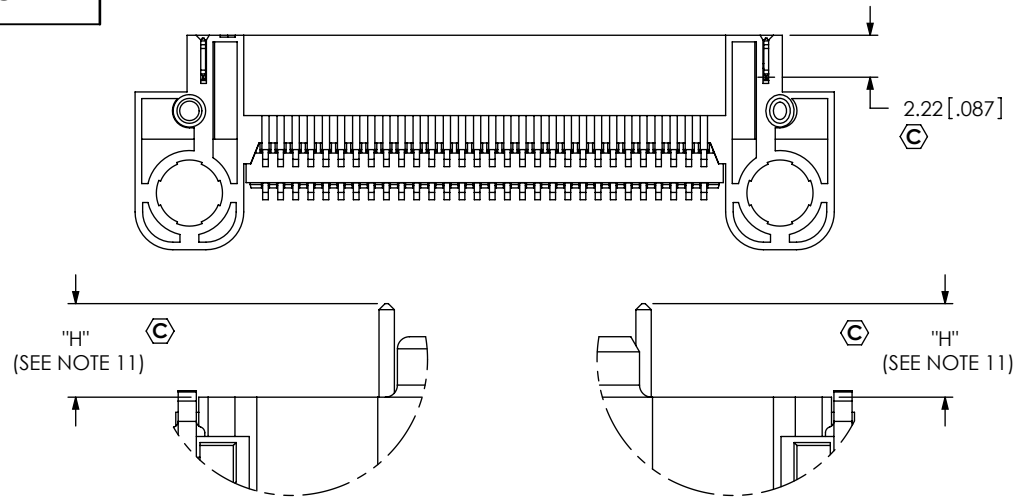

DETAIL 'G'
SCALE 8:1

DETAIL 'H'
SCALE 8:1

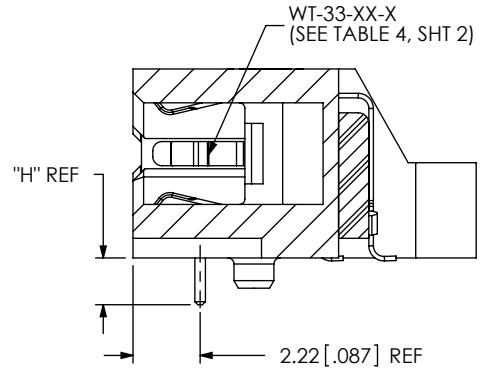
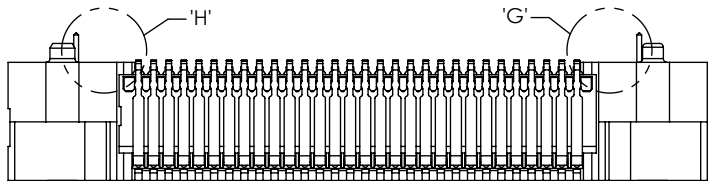

IN-PROCESS 13
(FILL WT-33-XX-X)

IN-PROCESS 14
(FILL T-1R37-XX-T)

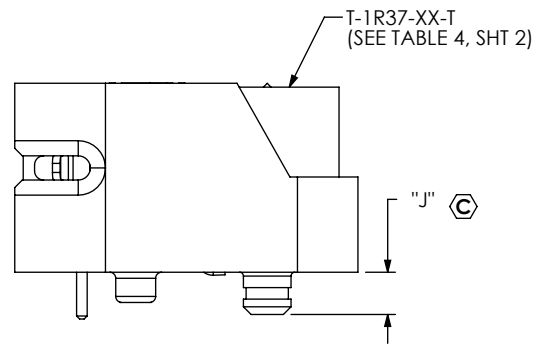

PROPRIETARY NOTE
 * THIS DOCUMENT CONTAINS CONFIDENTIAL AND PROPRIETARY INFORMATION AND ALL DESIGN, MANUFACTURING, REPRODUCTION, USE, PATENT RIGHTS AND SALES RIGHTS ARE EXPRESSLY RESERVED BY SAMTEC, INC. THIS DOCUMENT SHALL NOT BE DISCLOSED, IN WHOLE OR PART, TO ANY UNAUTHORIZED PERSON OR ENTITY NOR REPRODUCED, TRANSFERRED OR INCORPORATED IN ANY OTHER PROJECT IN ANY MANNER WITHOUT THE EXPRESS WRITTEN CONSENT OF SAMTEC, INC.

DO NOT SCALE DRAWING
 SHEET SCALE: 4:1

samtec

520 PARK EAST BLVD, NEW ALBANY, IN 47150
 PHONE: 812-944-6733 FAX: 812-948-5047
 e-Mail info@SAMTEC.com code 55322

DESCRIPTION:
 0.8mm DUAL ROW RIGHT ANGLE SOCKET ASSEMBLY

DWG. NO.
 ERF8-XXX-XX-X-D-RA-XXX-TR

BY: D BOYCE 08-10-2010 SHEET 6 OF 6