

MFG. ENG.	APPROVED BY:	DATE:	QA	APPROVED BY:	DATE:
-----------	--------------	-------	----	--------------	-------

PART NUMBER	USB TYPE	COUPLING TYPE
DCP-USBAB-F	USB 2.0, A TO A	QUICK CONNECT
DCP-USBAT-F	USB 2.0, A TO A	THREADED

NOTES:

- DCP-USBAB-F SHOWN IN EXPLODED VIEW. (USB 2.0 A TO USB 2.0 A WITH QUICK CONNECT COUPLING.)
- THE DIMENSION DOES NOT INCLUDE GASKET COMPRESSION.
- UNLESS OTHERWISE SPECIFIED, DIMENSIONS WITH TWO DECIMAL PLACES HAVE TOLERANCES OF ± 0.02 [± 0.5 mm].

MATERIALS:

GASKET: ELASTOMER, BLACK
 HEX NUT: THERMOPLASTIC, BLACK
 USB PANEL HOUSING: THERMOPLASTIC, BLACK
 USB A RECEPTACLE:
 SHELL: COPPER ALLOY, NICKEL PLATED
 CONTACTS: COPPER ALLOY, GOLD PLATED
 INSULATOR: THERMOPLASTIC, WHITE

ELECTRICAL:

CURRENT RATING: 1.5 A MINIMUM
 CONTACT RESISTANCE: 30 MILLIOHMS MAXIMUM
 INSULATION RESISTANCE: 1000 MEGAOHMS MINIMUM
 DIELECTRIC WITHSTANDING VOLTAGE: 200V DC

PRODUCT RATING:

IP-67 & IP-68, NEMA 250 (6P), WHEN MATED

OTHER:

OPERATING TEMPERATURE: -25°C TO $+85^{\circ}\text{C}$ [-13°F TO $+185^{\circ}\text{F}$]
 RECOMMENDED PANEL THICKNESS:
 QUICK CONNECT COUPLING: 1/32" TO 3/16" (0.8mm to 4.8mm)
 THREADED COUPLING: 1/32" TO 5/32" (0.8mm to 3.9mm)

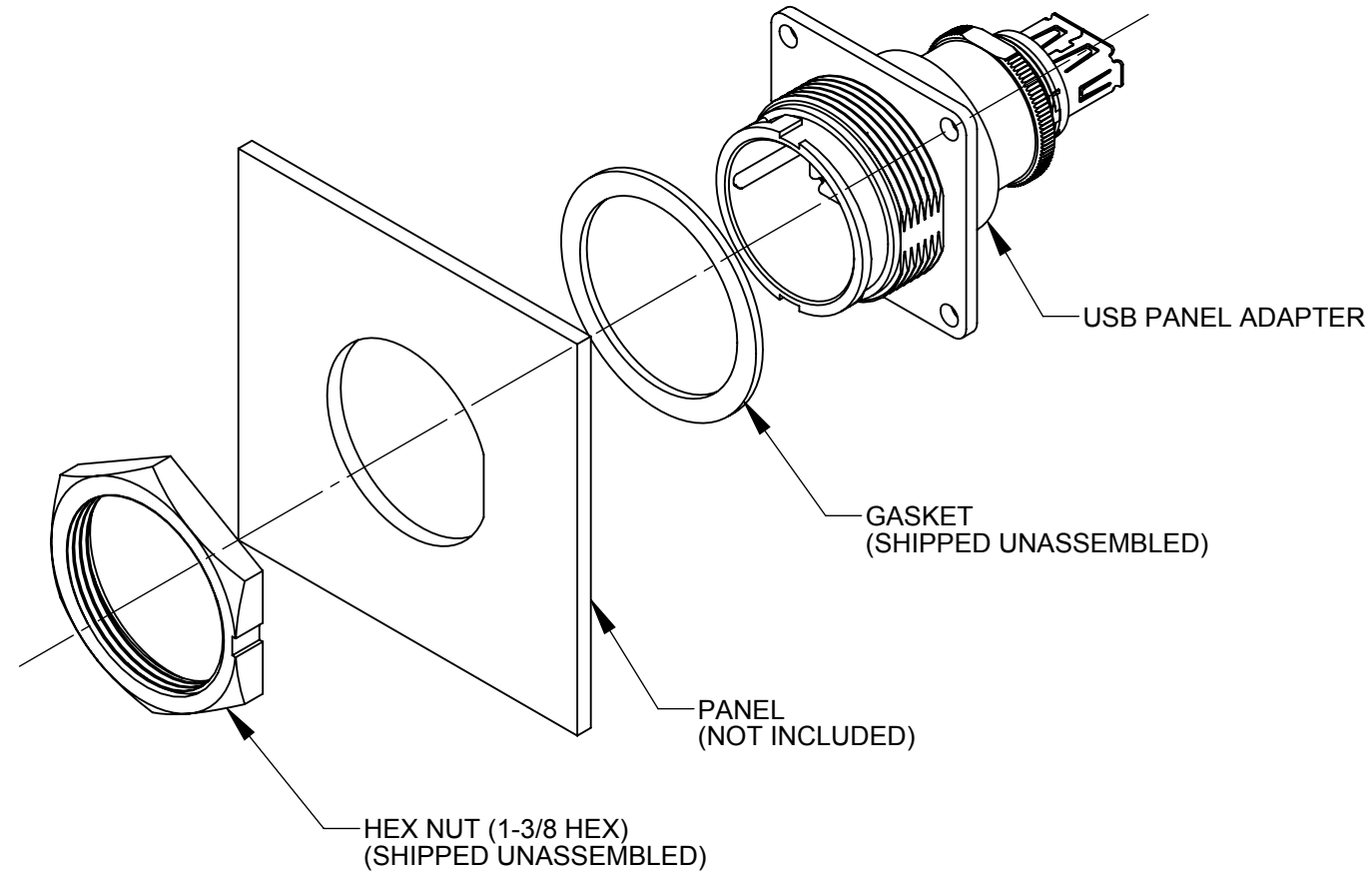

DCP-USBAB-F SHOWN

(USB A TO A ADAPTER WITH QUICK CONNECT COUPLING)

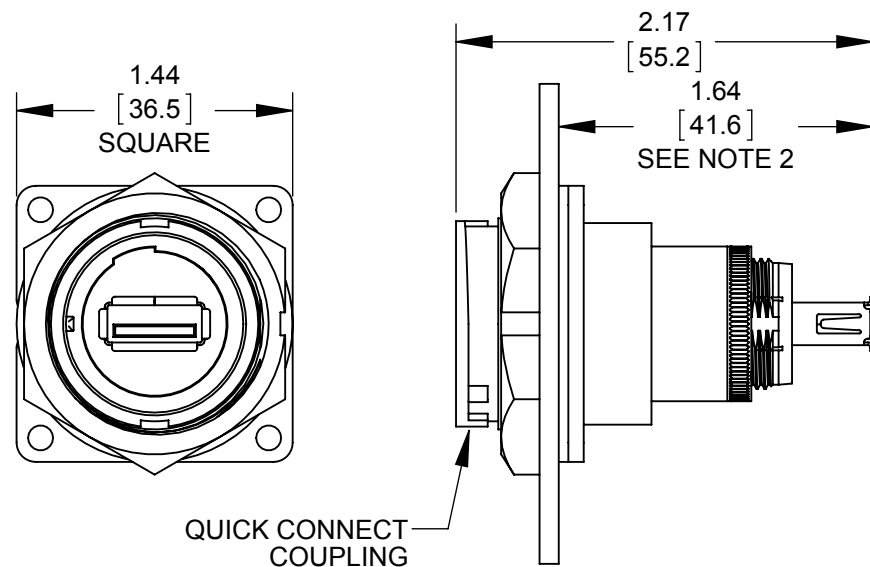

DCP-USBAT-F SHOWN

(USB A TO A ADAPTER WITH THREADED COUPLING)

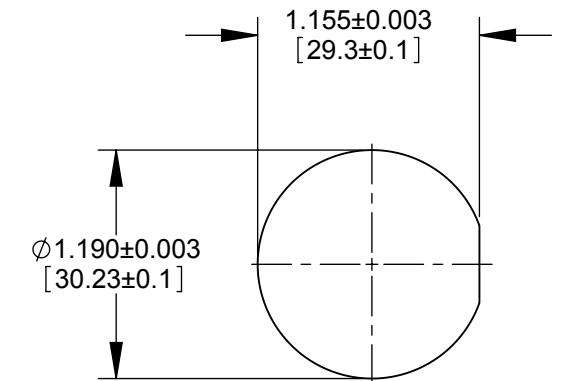
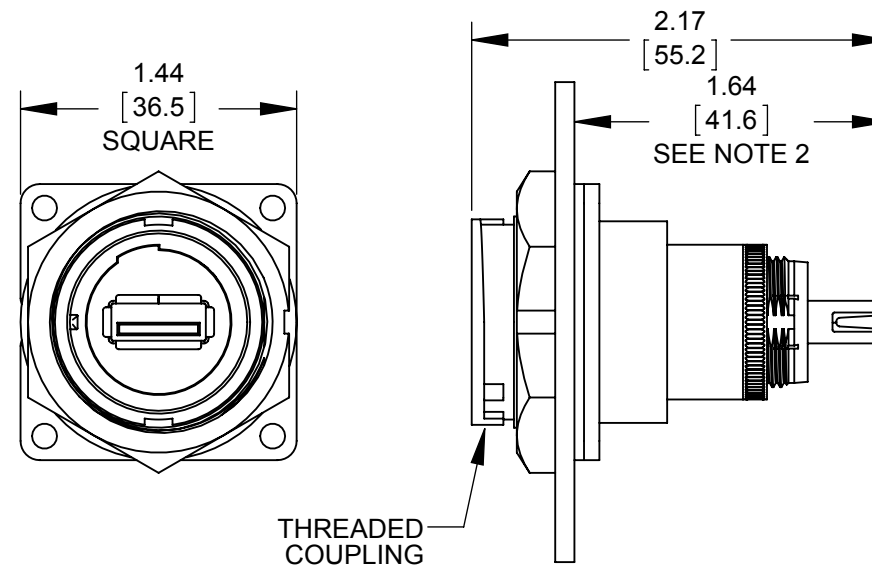

RECOMMENDED PANEL CUT-OUT
 QUICK CONNECT COUPLING
 OR THREADED COUPLING

DIMENSIONS IN BRACKET [] ARE METRIC.

RoHS COMPLIANT

PRELIMINARY		CUSTOMER DRAWING	
0A	JGK	9/26/14	DRAWING CREATED PER PROJECT #14008.
REV.	INIT.	DATE	DESCRIPTION
	JGK	9/26/14	ORIG. DRAWN BY: DATE: 9/26/14
ALL INFORMATION ILLUSTRATED IS THE PROPERTY OF CONXALL CORPORATION. UNAUTHORIZED DUPLICATION OR DISTRIBUTION OF THIS DOCUMENT IS PROHIBITED.			 601 E. WILDWOOD VILLA PARK, IL 60181
ALL UNITS ARE IN FEET, INCHES, FRACTION OF INCHES AND DECIMALS. UNLESS OTHERWISE SPECIFIED TOLERANCES: 3 PLACE DECIMALS ±.005 ANGLES ±1° FRACTIONS ±1/16			
APPROVED BY:		TITLE: USB A PANEL CONNECTOR	
SCALE: NTS		USB 2.0 A TO USB 2.0 A	
SIZE: B		DATA-CON-X	
SHEET: 1 OF 1		CUSTOMER: STANDARD PRODUCT	
FILE: SAME AS P/N	DIRECTORY: SLW	PART NUMBER: DCP-USBA SERIES	REV: 0A

CUSTOMER DRAWING

PART NUMBER: DCP-USBA SERIES