

NOTES:

- CONTACTS ARE ASSEMBLED INTO CONNECTOR.
- PARTS ARE TO BE BAGGED AS A KIT.
- ALL DIMENSIONS ARE FOR REFERENCE ONLY.

KIT PART NO.	CABLE OD.
W8882-9SG-522	.220-.250 [5.6-6.4mm]
W8882-9SG-528	.265-.285 [6.7-7.2mm]

NO. OF CONTACTS — GROMMET SIZES

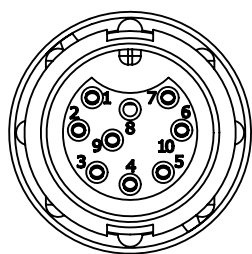

FACE VIEW

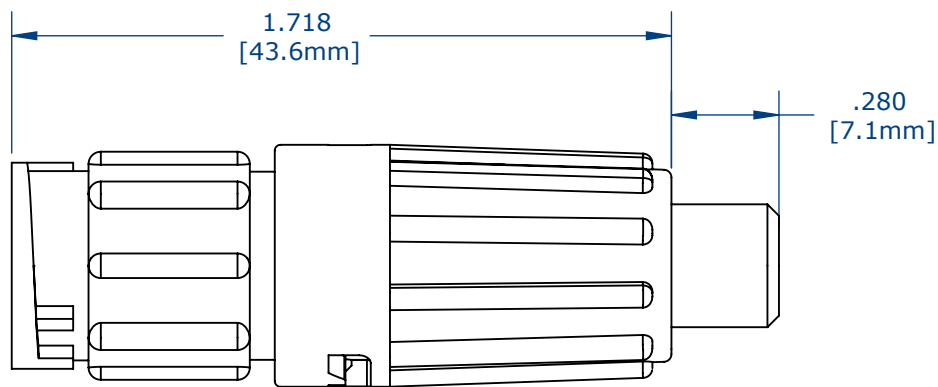

ASSEMBLED KIT VIEW
W8882-9SG-522 SHOWN

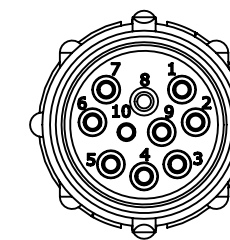

WIRE VIEW

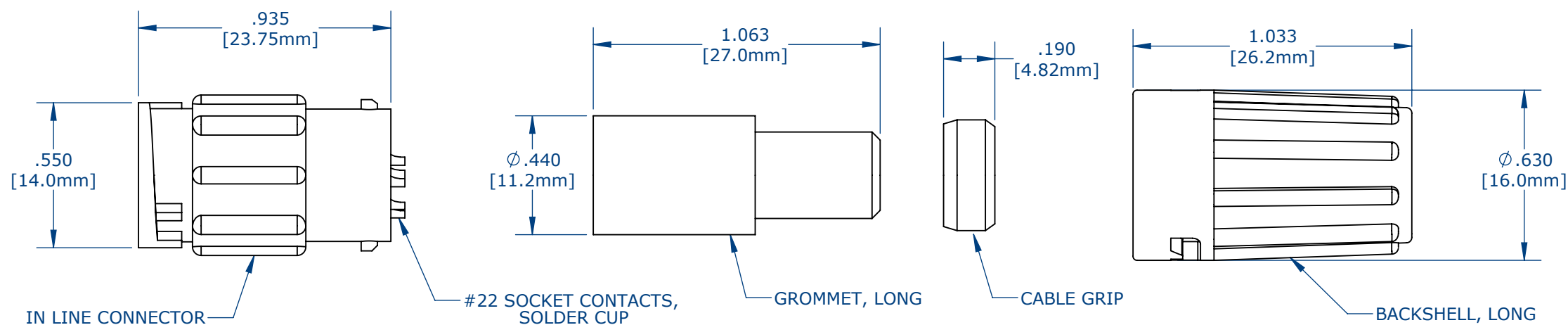

IN LINE CONNECTOR

#22 SOCKET CONTACTS, SOLDER CUP

GROMMET, LONG

CABLE GRIP

BACKSHELL, LONG

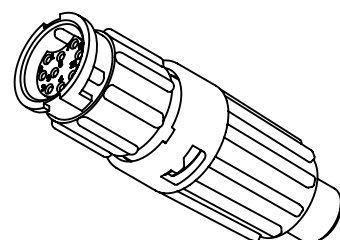

ASSEMBLED KIT FOR CUSTOMER REFERENCE

CUSTOMER DRAWING

CUSTOMER APPROVAL

THIS DOCUMENT CONTAINS CONFIDENTIAL INFORMATION PROPRIETARY TO CONXALL CORPORATION. ANY REPRODUCTION, DISCLOSURE, OR USE OF THIS DOCUMENT /INFORMATION IS EXPRESSLY PROHIBITED UNLESS AUTHORIZED IN WRITING BY CONXALL CORPORATION.

APPROVED BY: _____

DATE: _____

REV.	INIT.	DATE	DESCRIPTION
0A	AM	08/9/16	FIRST DRAWN
AM		08/09/16	

ALL INFORMATION ILLUSTRATED IS THE PROPERTY OF "CONXALL CORPORATION." UNAUTHORIZED DUPLICATION OR DISTRIBUTION OF THIS DOCUMENT IS PROHIBITED.			601 E. WILDWOOD VILLA PARK, IL 60181
ALL UNITS ARE IN FEET, INCHES, FRACTION OF INCHES AND DECIMALS. UNLESS OTHERWISE SPECIFIED TOLERANCES: 3 PLACE DECIMALS ±.005 ANGLES ±1° FRACTIONS ±1/16			
APPROVED BY: _____		SCALE: NTS SIZE: B SHEET: 1 OF 1	TITLE: IN-LINE CONNECTOR, KIT (9) #22 SOCKET CONTACT, SOLDER MINI-CON-X CUSTOMER: STANDARD PRODUCT
FILE: _____	DIRECTORY: SLW	PART NUMBER: W8882-9SG-5XX	REV 0A