

CUSTOMER PRINT

PART NUMBER: X6882-10SG-522

NOTES:

- CONTACTS ARE ASSEMBLED INTO CONNECTOR.
- PARTS ARE TO BE BULK PACKED.
- ALL DIMENSIONS ARE FOR REFERENCE ONLY.

ASSEMBLY P/N	CABLE O.D
W6882-10SG-522	0.220 - 0.250
W6882-10SG-528	0.265 - 0.285

NO. OF CONTACTS — GROMMET SIZE

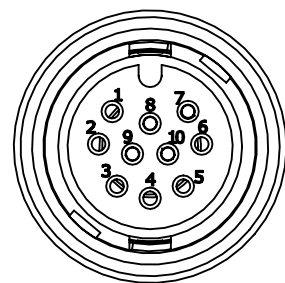

FRONT VIEW

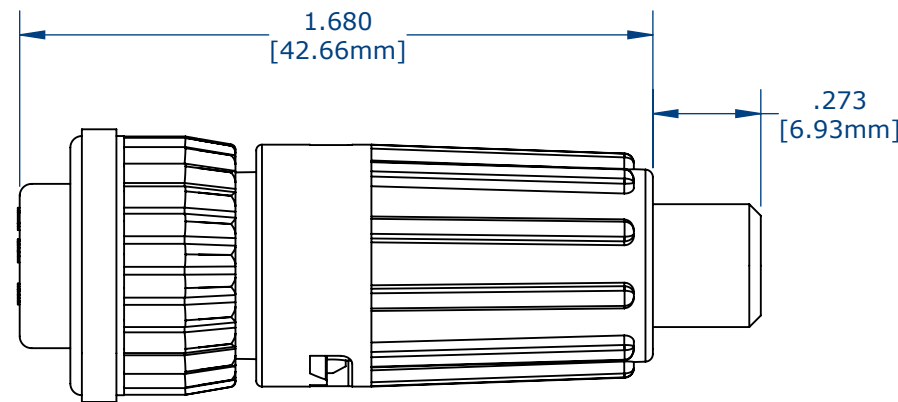

ASSEMBLED KIT VIEW

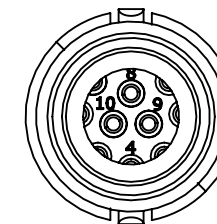

WIRE VIEW

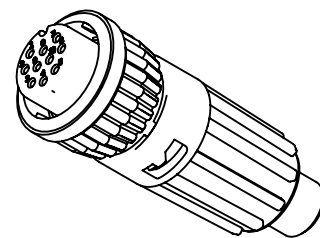
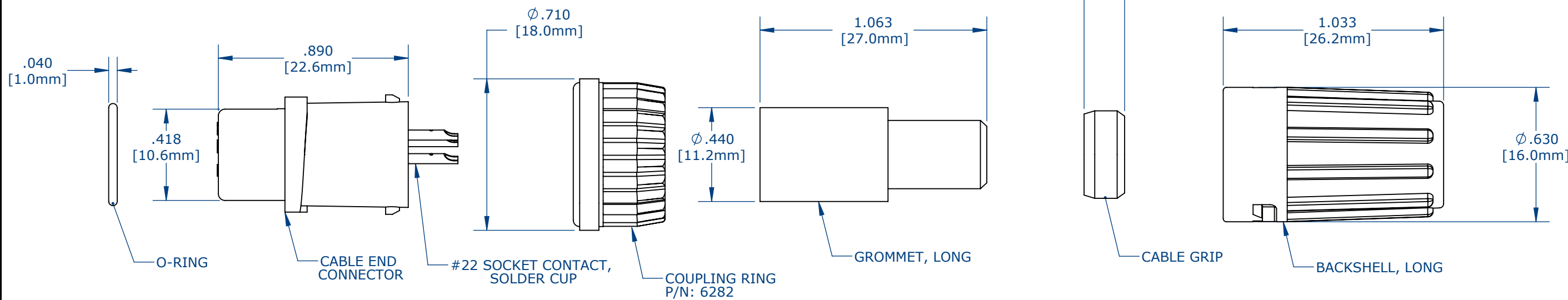

ASSEMBLED KIT FOR CUSTOMER REFERENCE

CUSTOMER DRAWING

WIRE COLOR CODE (REF)									
POS. 1	POS. 2	POS. 3	POS. 4	POS. 5	POS. 6	POS. 7	POS. 8	POS. 9	POS.10

CUSTOMER APPROVAL

THIS DOCUMENT CONTAINS CONFIDENTIAL INFORMATION PROPRIETARY TO CONXALL CORPORATION. ANY REPRODUCTION, DISCLOSURE, OR USE OF THIS DOCUMENT /INFORMATION IS EXPRESSLY PROHIBITED UNLESS AUTHORIZED IN WRITING BY CONXALL CORPORATION.

APPROVED BY: _____

DATE: _____

0A	AM	04/05/16	FIRST DRAWN
REV.	INIT.	DATE	DESCRIPTION
<small>ALL INFORMATION ILLUSTRATED IS THE PROPERTY OF "CONXALL CORPORATION." UNAUTHORIZED DUPLICATION OR DISTRIBUTION OF THIS DOCUMENT IS PROHIBITED.</small>		<small>ORIG. DRAWN BY: AM</small> <small>DATE: 04/05/16</small>	<p>601 E. WILDWOOD VILLA PARK, IL 60181</p>
<small>ALL UNITS ARE IN FEET, INCHES, FRACTION OF INCHES AND DECIMALS.</small>		<small>CHECKED BY:</small> <small>APPROVED BY:</small>	
<small>UNLESS OTHERWISE SPECIFIED TOLERANCES: 3 PLACE DECIMALS ±.005 ANGLES ±1° FRACTIONS ±1/16</small>		<small>SCALE: NTS</small> <small>SIZE: B</small> <small>SHEET: 1 OF 1</small>	<small>CUSTOMER:</small> W6882-10SG-5XX
<small>△ - CRITICAL CHARACTERISTIC FLAG PER SPEC. XXXX</small>		<small>FILE:</small> <small>DIRECTORY: SLW</small>	<small>PART NUMBER:</small> W6882-10SG-5XX
			<small>REV</small> 0A