

Pb THIS PRODUCT MANUFACTURED WITH LEAD-FREE PROCESSING

DESIGNED & DIMENSIONED IN MILLIMETERS [INCHES]

SMP-PX-P-XX-ST-EM3

DO NOT SCALE FROM THIS PRINT

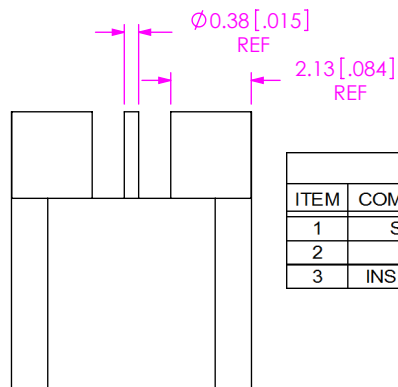

INTERFACE	SMP-PX-P-X-ST-EM3-SHL
-F	SMP-PF-P-X-ST-EM3-SHL
-L	SMP-PL-P-X-ST-EM3-SHL
-S	SMP-PS-P-X-ST-EM3-SHL

GENDER
-P: PLUG

INTERFACE
-F: FULL DETENT
-L: LIMITED DETENT
-S: SMOOTH BORE

TYPE
-P: PCB

TERMINATION
-EM3: DROP-IN EDGE MOUNT

ORIENTATION
-ST: STRAIGHT

PLATING SPECIFICATION
(VALUES GIVEN ARE IN MICRO-INCHES)
-HE: 30µ" GOLD ON CENTER CONTACT
50µ" GOLD ON OUTER CONTACT
-HH: 30µ" GOLD ON CENTER CONTACT
30µ" GOLD ON OUTER CONTACT
(SEE TABLE 1 & NOTE 4)

ITEM	COMPONENT	-HE	-HH
1	SHELL	SMP-PX-P-E-ST-EM3-SHL (SEE TABLE 2)	SMP-PX-P-H-ST-EM3-SHL (SEE TABLE 2)
2	PIN	SMP-P-P-H-ST-EM3-PIN	
3	INSULATOR	SMP-P-P-ST-EM3-INS	

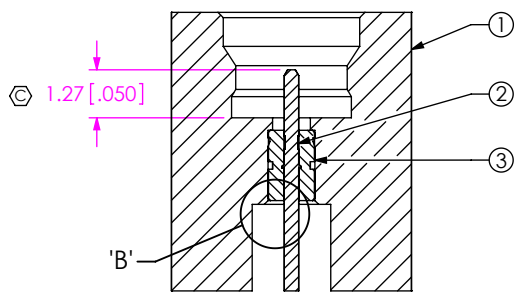
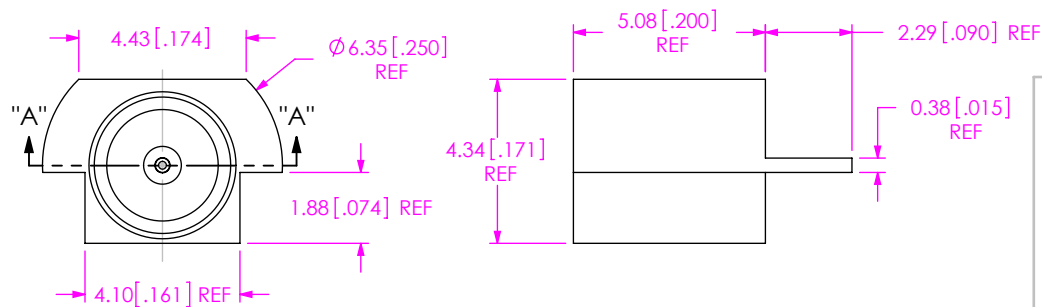

SECTION "A"-"A"

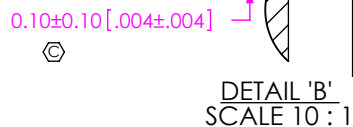
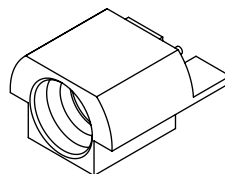

DETAIL 'B'
SCALE 10 : 1

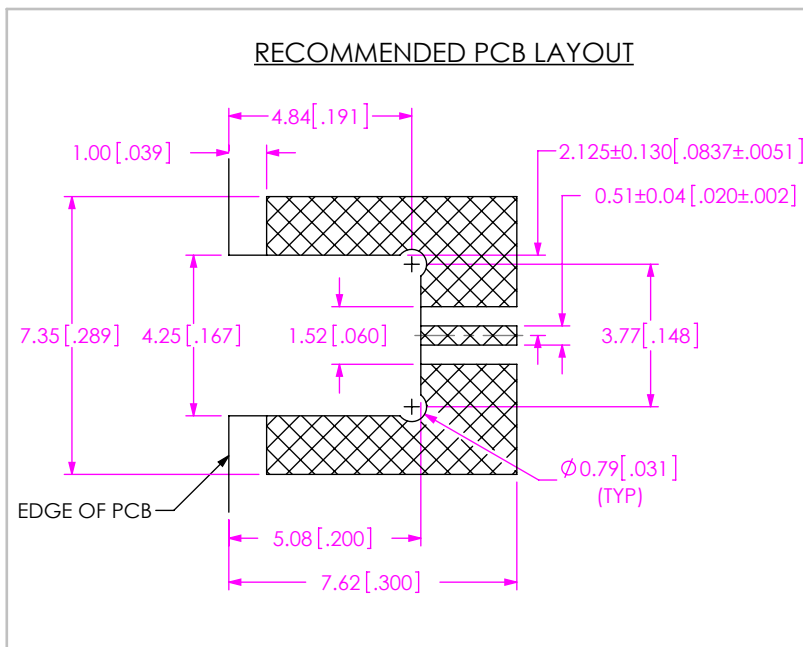

NOTES:

- ⊗ REPRESENTS A CRITICAL DIMENSION.
- MINIMUM PUSHOUT FORCE FOR CENTER CONTACT: 6.67N [1.5 LB].
INSULATOR: 6.67N [1.5 LB].
- PRODUCT TO BE PACKAGED PER PACKING STANDARD CO-HD-WI-3040-M.
TRAY: TY-SMA001-1
COVER: TY-SMA001-2
200 PARTS PER TRAY (2 PARTS PER POCKET)
- PLATING THICKNESS ON OUTER CONTACT MUST BE 30µ" MIN, TO AVOID REFLOW WICKING.

<p>UNLESS OTHERWISE SPECIFIED, DIMENSIONS ARE IN MILLIMETERS.</p> <p>TOLERANCES ARE:</p> <table border="0"> <tr> <td>DECIMALS</td> <td>ANGLES</td> </tr> <tr> <td>X.X: ±0.3 [0.1]</td> <td>5°</td> </tr> <tr> <td>X.XX: ±0.13 [0.05]</td> <td></td> </tr> <tr> <td>X.XXX: ±0.051 [0.020]</td> <td></td> </tr> </table>	DECIMALS	ANGLES	X.X: ±0.3 [0.1]	5°	X.XX: ±0.13 [0.05]		X.XXX: ±0.051 [0.020]		<p>PROPRIETARY NOTE</p> <p>THIS DOCUMENT CONTAINS CONFIDENTIAL AND PROPRIETARY INFORMATION AND ALL DESIGN, MANUFACTURING, REPRODUCTION, USE, PATENT RIGHTS AND SALES RIGHTS ARE EXPRESSLY RESERVED BY SAMTEC, INC. THIS DOCUMENT SHALL NOT BE DISCLOSED, IN WHOLE OR PART, TO ANY UNAUTHORIZED PERSON OR ENTITY NOR REPRODUCED, TRANSFERRED OR INCORPORATED IN ANY OTHER PROJECT IN ANY MANNER WITHOUT THE EXPRESS WRITTEN CONSENT OF SAMTEC, INC.</p>	<p>520 PARK EAST BLVD., NEW ALBANY, IN 47150 PHONE: 812-944-6733 FAX: 812-948-5047 e-Mail info@SAMTEC.com code 55322</p>
	DECIMALS	ANGLES								
X.X: ±0.3 [0.1]	5°									
X.XX: ±0.13 [0.05]										
X.XXX: ±0.051 [0.020]										
<p>MATERIAL: DO NOT SCALE DRAWING SHEET SCALE: 5:1</p> <p>PIN, SHELL: BRASS DIELECTRIC: PTFE</p>	<p>DESCRIPTION: SMP EDGE MOUNT PLUG - 50 OHM</p> <p>DWG. NO. SMP-PX-P-XX-ST-EM3</p> <p>BY: T MEEK 10/29/2010 SHEET 1 OF 1</p>									