

5

4

3

2

1

DRAWING NO.
40-9415HDM-CUST

REVISIONS

01	OFFICIAL RELEASE			
	11-26-09	Y	U	Y

Betty 2009122
514:28:47
+03900

Description: HI-Density Crimp 15 Pin Male

Part No: 40-9415HDM

Application: 94 Series D-Sub Connector

Crimp Tool: N/A

Impedance: N/A

Frequency Range: N/A

Material: Shell Steel, Tin plated
Insulator PBT+Fiber-grass, UL94-V0

RoHS Compliance: Yes

Technical Detail: N/A



D

D

C

C

B

B

A

A

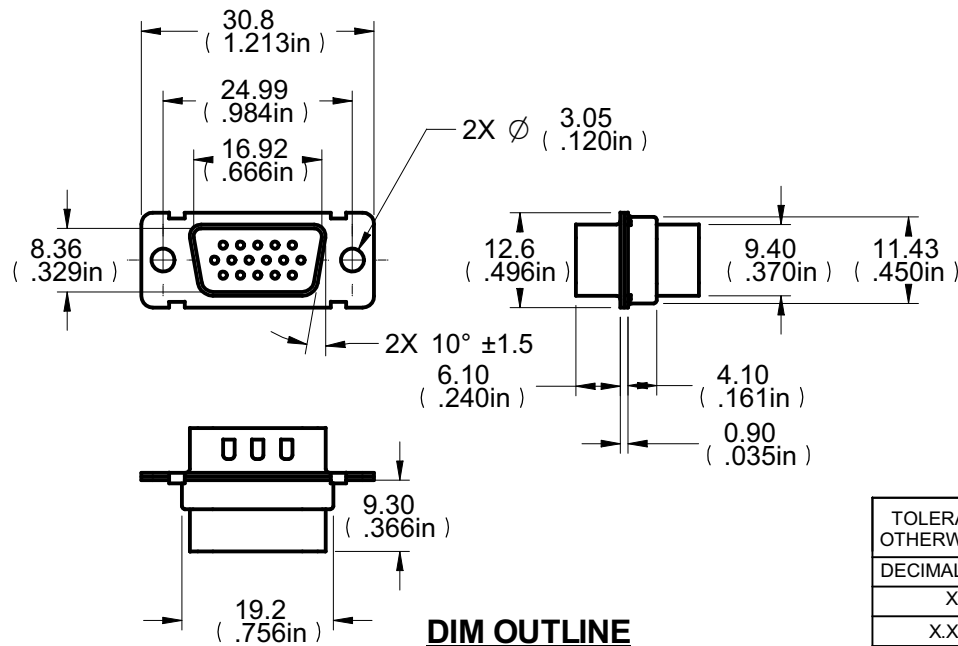

CUSTOMER COPY

TOLERANCE UNLESS OTHERWISE SPECIFIED		DRAWN BY	DATE
DECIMALS	mm	BETTY.YU	11-26-09
X	± 0.5	CHECKED BY	DATE
X.X	± 0.3	BETTY.YU	11-26-09
X.XX	± 0.2	APPROVED BY	DATE
ANGLES	± 0.5°	THOMAS	11-26-09
		U/M	mm



TITLE
HI-DENSITY CRIMP 15 PIN MALE

SHEET	DRAWING NO.	SIZE
1 OF 1	40-9415HDM-CUST	A

THIS DRAWING WAS PRODUCED BY COMPUTER,
DO NOT SCALE DRAWING OR UPDATE MANUALLY.

5

4

3

2

1