

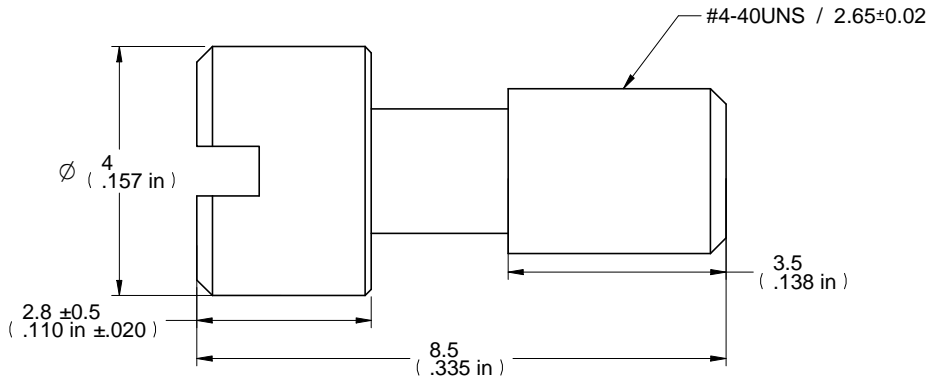

DESCRIPTION: M SCREW RETAINER,.310"  
 MODEL NUMBER: 40-98440M(-C)  
 APPLICATION: D-SUB HARDWARE  
 CRIMP TOOL: N/A  
 IMPEDANCE: N/A  
 FREQUENCY RANGE: N/A  
 MATERIAL: WASHER STEEL PASSIVATION  
 BOLT BRASS NICKEL PLATED  
 RoHS COMPLIANCE: YES  
 TECHNICAL DETAIL: N/A

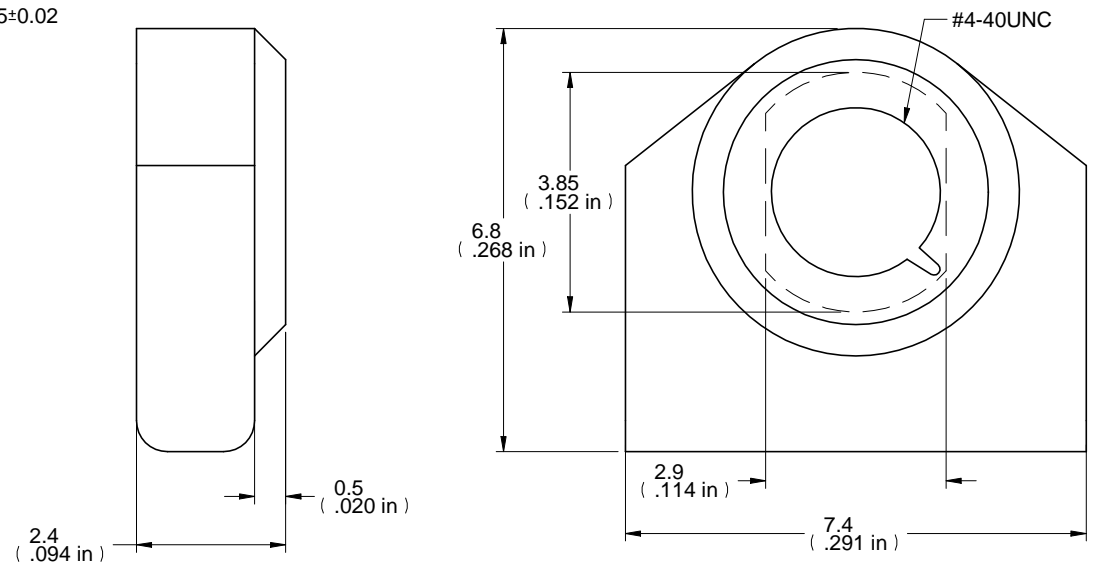

**DIM OUTLINE**



MODEL NUMBER	PACKAGE
40-98440M	1 SET
40-98440M-C	50 SETS

		<b>AIM-Cambridge</b>	
	<b>RoHS</b> 2002/95/EC	Title: M SCREW & RETAINER, 0.30"	
<small>This PROPRIETARY Document is property of Cinch Connectivity Solutions. It is confidential in nature, non-transferable, and issued with the clear understanding that it is not traced or copied without permission and is returnable upon demand.</small>	<small>UNLESS OTHERWISE SPECIFIED UNITS: METRIC</small>	Model No. 40-98440M(-C)	
<small>INTERPRET DRAWING IN ACCORDANCE WITH ASME Y14.5-2009.</small>	.XX ±.51 .XXX ±.127 ANGLES ±2°	Size A DO NOT SCALE DRAWING	Date: 8/3/2013 Sheet 1 of 1