

BOX ENCLOSURES, INC

28835 N. HERKY DRIVE, #114,
LAKE BLUFF, IL 60044

WWW.BOXENCLOSURES.COM

TEL: 847-932-4700

FAX: 847-932-4701

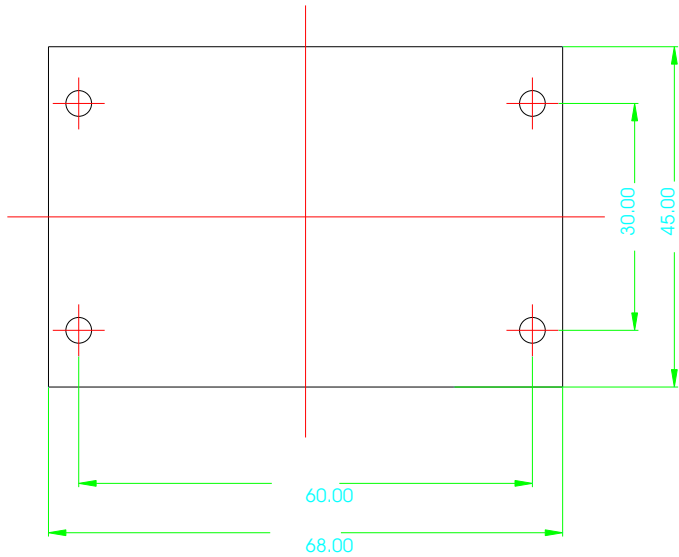
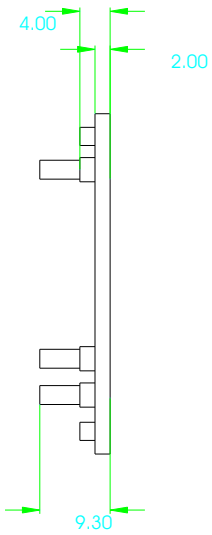
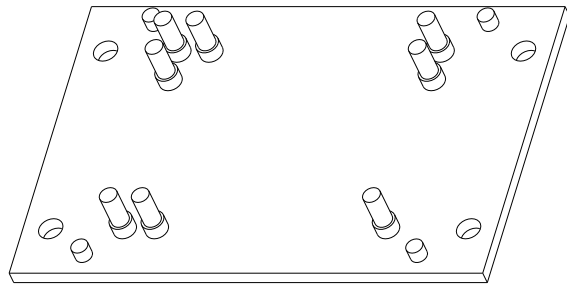

Title: **bd-15-bottom**

Material: **ABS**
Finish:

TOLERANCE
all dimension in mm
unless otherwise specified.
x %%p0.20
.x %%p0.10
.xx %%p0.05
ANGLE %%P0.5%cd

Dwg. No.:

Revision:

Model:

Part No.:

Color:

Dim. Date
2004-12-29

Qty:

Chk. Date

FOR A SPECIFIC PURPOSE. THE RECIPIENT AGREES TO USE IT ONLY FOR

Proj.



Sheet

App. Date

A4
1 of 1



Around-
R0.20

1.60

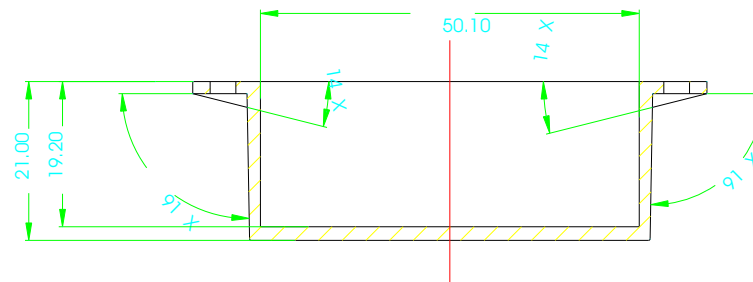
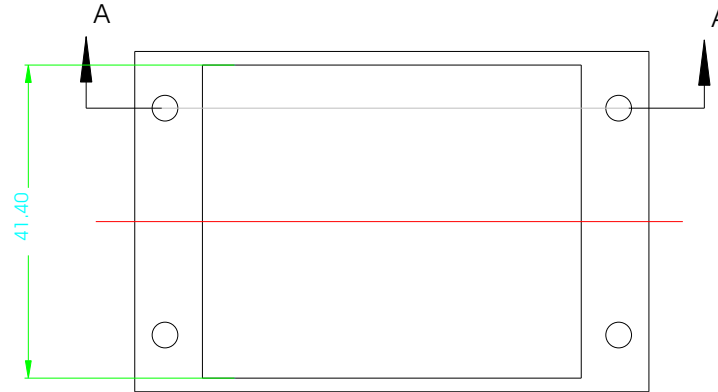
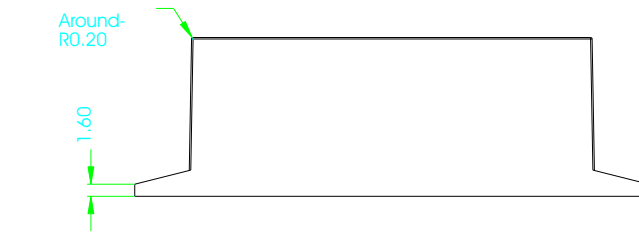

SECTION

THIS DRAWING IS THE PROPERTY OF AND MAY EMBODY PROPRIETARY INFORMATION OWNED BY X-Box Enclosures. IT IS PROVIDED UNDER A CONFIDENTIAL RELATIONSHIP FOR A SPECIFIC PURPOSE. THE RECIPIENT AGREES TO USE IT ONLY FOR SUCH PURPOSE AND RETURN IT TO X-Box Enclosure UPON REQUEST.