

Recommended PCB Layout

Viewed from component side, General Tol: ±0.05

■ Solder Area ■ Keep Out Area □ Component Outline

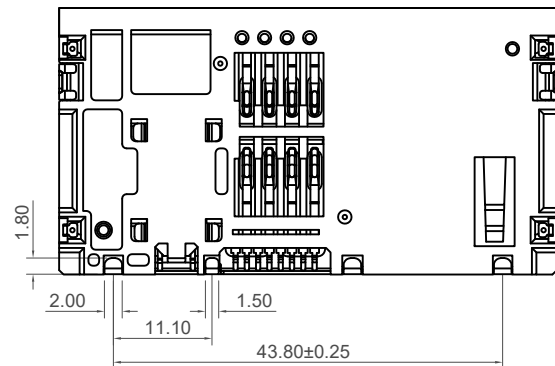
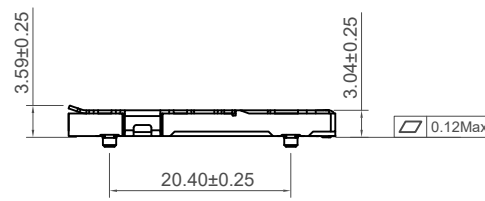
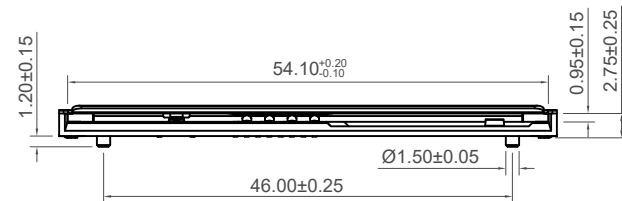

Ordering Grid

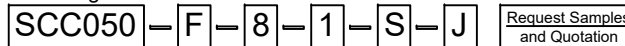

Contact Type

F = Friction

No. of Contacts

8 = 8 Contacts

Switch

1 = Sealed switch, normally open

Packing

J = Tray with Film
(20pcs per tray)

Shielding

S = Shielded

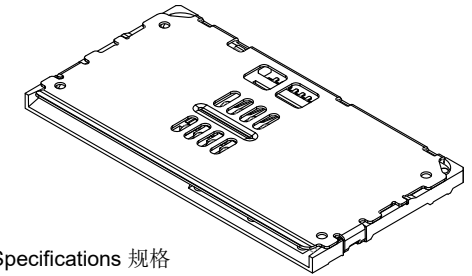

Specifications 规格

Material 物料

Plastic Housing 塑胶外壳: Hi-Temp Thermoplastic
UL94V-0, Black
Contact Terminal 接触端子: Copper Alloy, C5210
Metallic Shell 金属外壳: Stainless Steel, SUS304
Switch Button 开关压片: Stainless Steel, SUS301
Switch Contact 开关接触: Copper Alloy, C5210
Grounding Tag 接地片: Brass, C2680

Plating 电镀

Under-plating 底层电镀: 30µm min. Nickel all over
Data Contact 数据端子:
Contact Area 接触区: 10µm Gold
Solder Area 焊接区: 100µm Tin
Switch Contact 开关接触:
Contact Area 接触区: 10µm Silver
Solder Area 焊接区: 100µm Tin
Grounding Tag 接地片:
Solder Area 焊接区: 100µm Tin

Electrical 电气

Voltage rating 电压额定值: 30V max.
Current Rating 电流额定值: 1 Amp
Contact Resistance 接触电阻值: 100 mΩ max.
Insulation Resistance 绝缘电阻值: 1000 MΩ min.
Dielectric Withstand Voltage 耐电压: 500 V AC

Mechanical & Environmental 机械 & 环境

Solderability 可焊性:
IR Reflow 回流焊: 250°C for 5 sec. max.
Manual Solder 人工焊接: 370°C for 3 sec. max.

Operating Temperature 工作温度: -40°C to +85°C
Durability 耐久性: 500,000 cycles

Electric Function	Detect Switch
Without Card	Open
Card Inserted	Closed

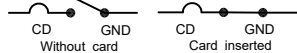

Switch Operation Diagram

Part Number		Product Description	
SCC050		Smart Card Connector - Friction Contact Type, 8 Contact, Standard Mount, with Normally Open Sealed Switch	
Drawing Date		5th August 2015	
By	AJO	Tolerances (Except as Noted)	Units:
Detail	Drawing Release	Length: X. ± 0.35	Angle: X.° ± 5°
Revision	A	X.X ± 0.30	X.XX° ± 4°
Date	05/08/15	X.XX ± 0.25	X.XXX° ± 3°
		X.XXX ± 0.10	X.XXX° ± 2°



This drawing is confidential and copyright of Global Connector Technology, Ltd (GCT). This drawing must not be copied or disclosed without written consent. E & OE



Not to Scale	Drawn By AJO	Sheet No. 1/2
--------------	--------------	---------------

Part Number	Pcs/Tray	Trays/Carton	Cartons/Box	Pcs/Box
SCC050	20	18 (+2 empty)	5	1800

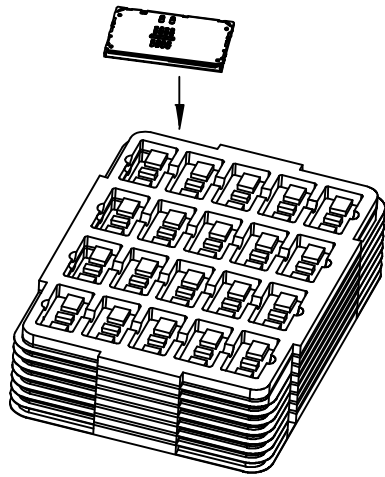

20pcs per tray
Tray : 21.75cm L x 31.5cm W x 1.40cm H

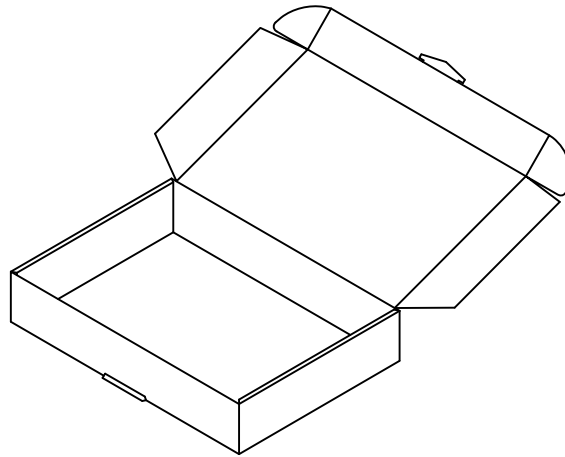



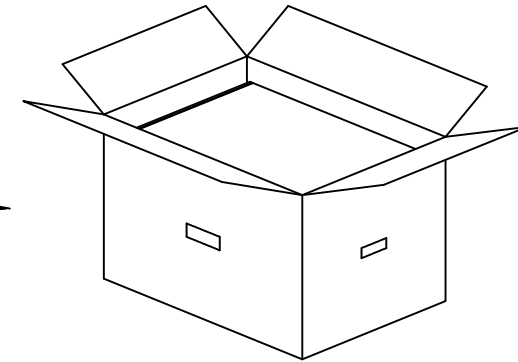

360pcs per carton (18 trays set in order plus two empty trays)
Carton: 46.0cm L x 32.0cm W x 8.80cm H
Net Weight: 2.66kg Gross Weight: 3.63kg

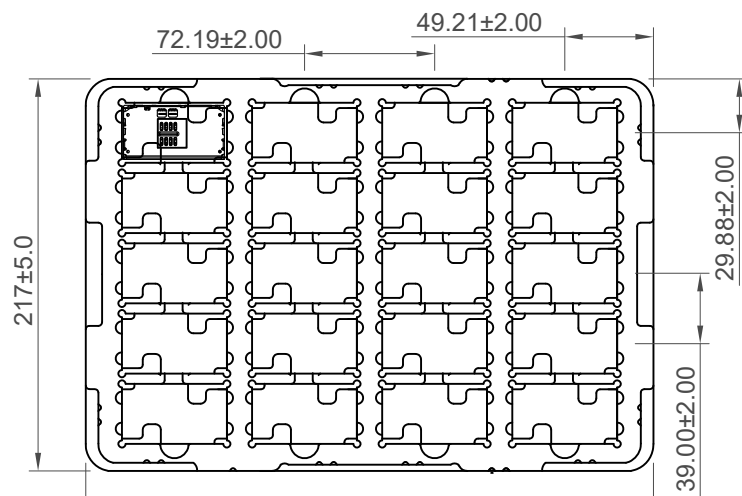

1800pcs per box (5 cartons set in order)
Box: 48.0cm L x 34.6cm W x 46.00cm H
Net Weight: 13.30kg Gross Weight: 19.08kg



Part Number		Product Description		 www.gct.co
SCC050		Smart Card Connector - Friction Contact Type, 8 Contact, Standard Mount, with Normally Open Sealed Switch		
Drawing Date		5th August 2015		
By	AJO	Tolerances (Except as Noted)	Units:	  This drawing is confidential and copyright of Global Connector Technology, Ltd (GCT). This drawing must not be copied or disclosed without written consent. E & OE
Detail	Drawing Release	Length	Angle	
Revision	A	Metric (mm)		
Date	05/08/15	 3rd Angle Projection		
Not to Scale		Drawn By	AJO	Sheet No.
				2/2