

1		2			3			4		
COUNT	DESCRIPTION OF REVISIONS	BY	CHKD	DATE	COUNT	DESCRIPTION OF REVISIONS	BY	CHKD	DATE	
△				. .	△				. .	
△				. .	△				. .	
△				. .	△				. .	

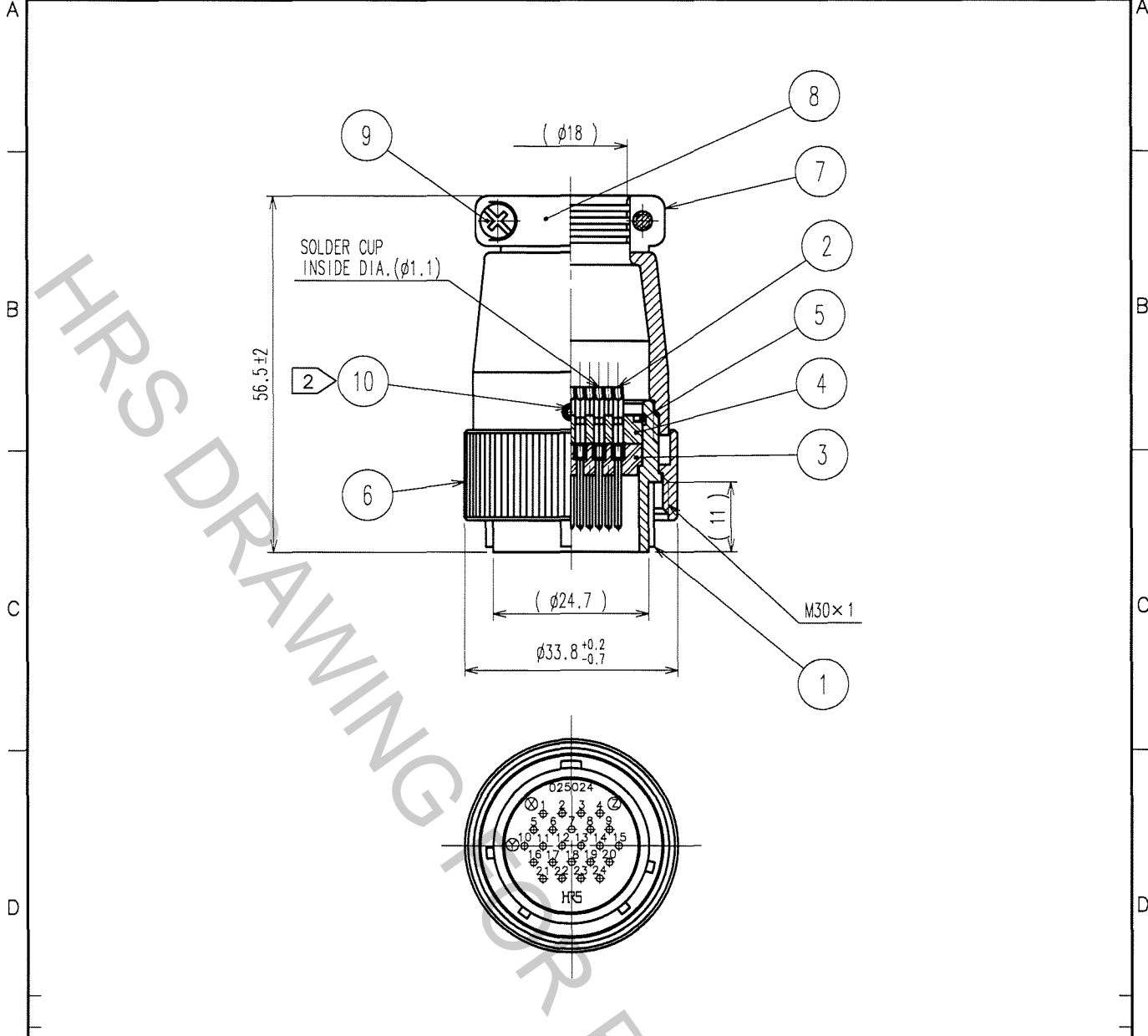

NOTES 1. ROTATION EXAMPLES OF REF. NO. ① AND ⑦ ARE SHOWN.
 ② ACROSS FLATS OF HEAGON HEAD OF REF. NO. ⑩ TO BE 1.27mm.

5	PHOSPHOR BRONZE	NICKEL PLATING	10	STEEL	NICKEL PLATING, HEX SOCKET SET SCREW M2.6×0.45×2
4	PHENOL FORMALDEHYDE	(BLACK) UL94V-0	9	BRASS	NICKEL PLATING M3×0.5×10
3	PHENOL FORMALDEHYDE	(BLACK) UL94V-0	8	ALUMINUM ALLOY	MATTE FINISH NICKEL PLATED
2	COPPER ALLOY	SILVER PLATING, 3μm min	7	ALUMINUM ALLOY	MATTE FINISH NICKEL PLATED
1	ALUMINUM ALLOY	MATTE FINISH NICKEL PLATED	6	ALUMINUM ALLOY	MATTE FINISH NICKEL PLATED
NO.	MATERIAL	FINISH, REMARKS	NO.	MATERIAL	FINISH, REMARKS

CODE NO. (OLD)		DRAWN	DESIGNED	CHECKED	APPROVED	RELEASED
		<i>J. Aburū</i>	<i>E. Kawanishi</i>		<i>M. Sato</i>	
		<i>06.03.26</i>	<i>06.03.26</i>		<i>06.03.27</i>	
DRAWING NO. EDC4-024134-71			PART NO. JR25PK-24P(71)			
HRS HIROSE ELECTRIC CO., LTD.			CODE NO. CL114-0508-6-71			1/1

TO
R