

DRAWING FILE NO. AA1-B0-34-620-5D1-C		REV 07-25-17
REVISIONS		
DATE	DESCRIPTION	
07-25-17	DRAWING CREATED	

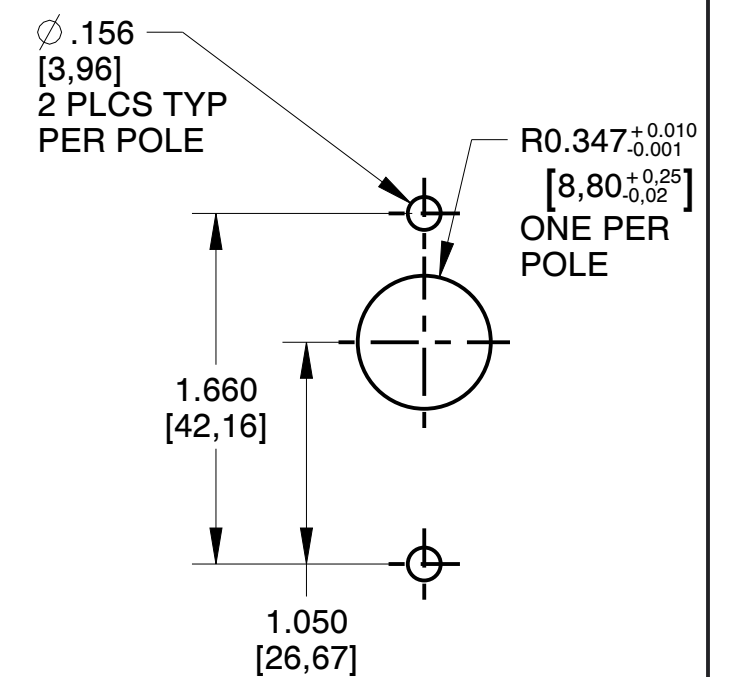
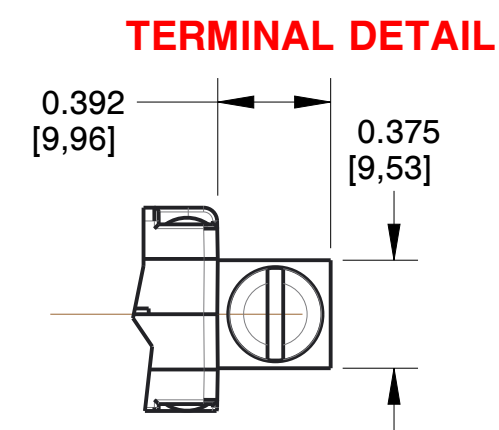
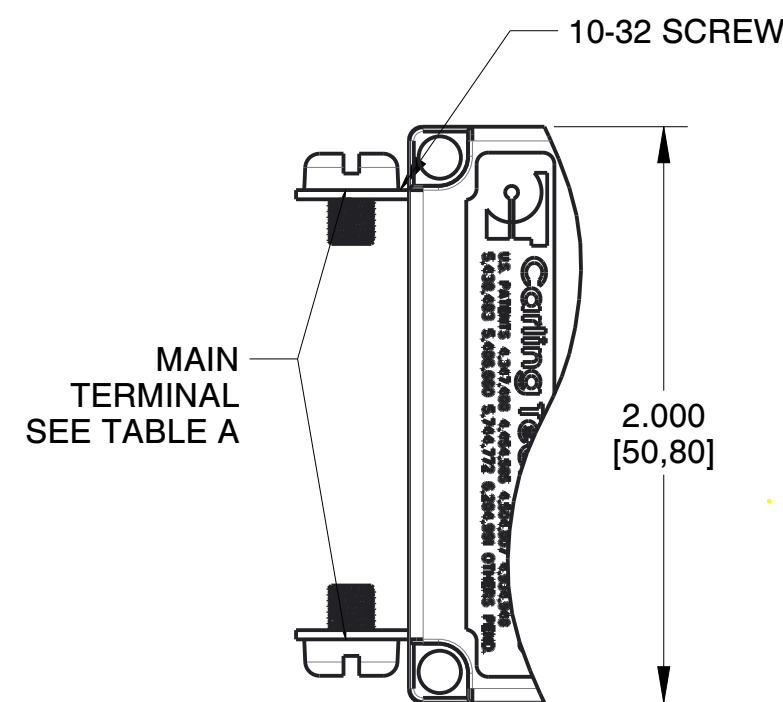
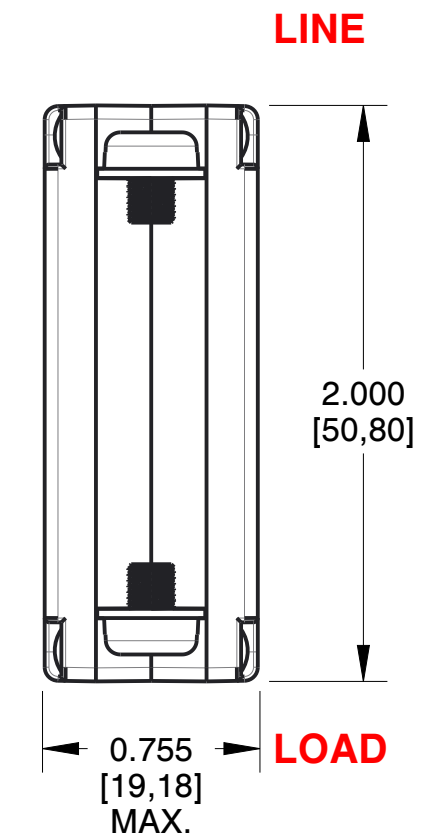
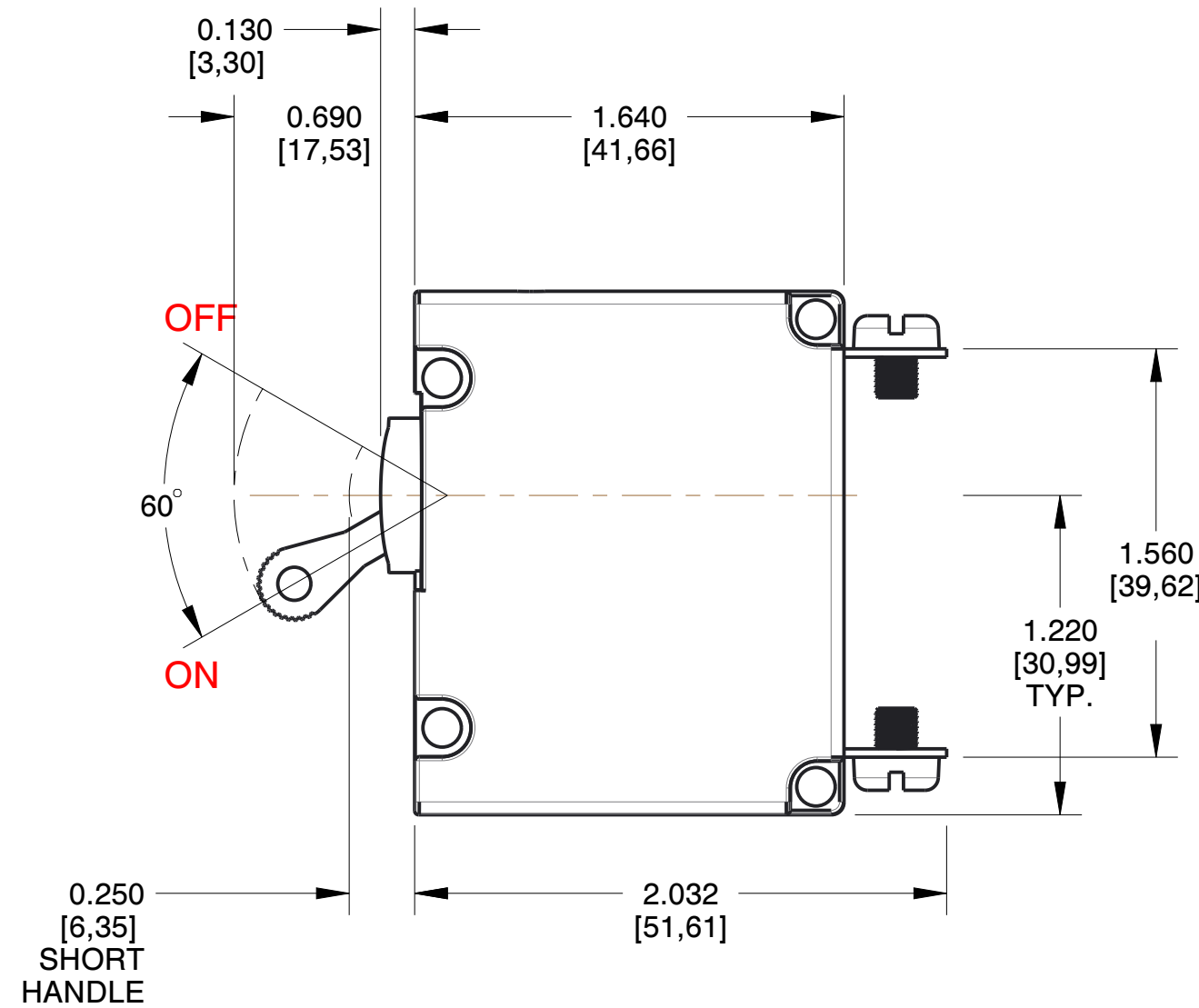
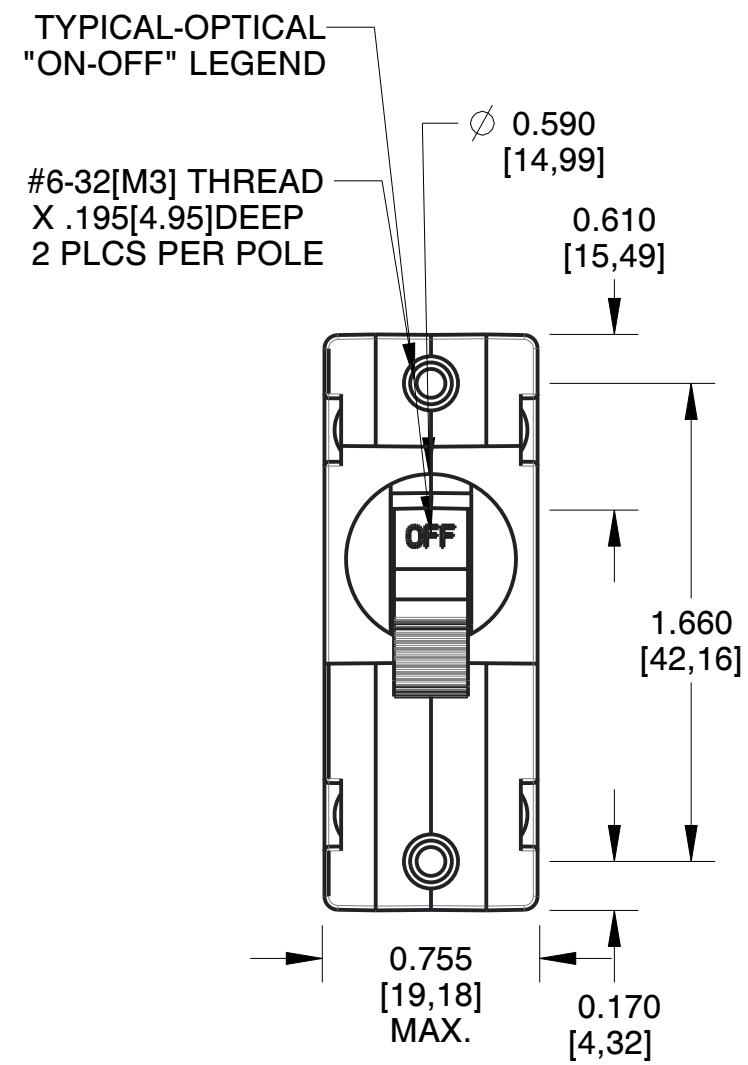

PANEL CUTOUT DETAIL

Carling Technologies
Innovative Designs. Powerful Solutions.

60 JOHNSON AVE
PLAINVILLE, CT 06062, USA
PHONE: (860) 793-9281
SALES: SALES@CARLINGTECH.COM
APPLICATION SUPPORT: TEAM2@CARLINGTECH.COM

CIRCUIT SCHEMATIC		TABLE A TIGHTENING TORQUE SPECIFICATIONS	
ANSI		THREAD SIZE	TORQUE
SERIES TRIP		#6-32 & M3 MOUNTING HARDWARE	7-9- IN-LBS [0.8-1.0 NM]
LINE		#8-32 & M4 THREAD TERMINAL SCREW	12-15 IN-LBS [1.4-1.7 NM]
LOAD		#10-32 & M5 THREAD TERMINAL SCREW	15-20 IN-LBS [1.7-2.3 NM]

PROPRIETARY NOTICE
NOTICE TO ALL PERSONS RECEIVING THIS DRAWING: THIS DOCUMENT IS THE PROPERTY OF CARLING TECHNOLOGIES, INC. AND IS NOT TO BE DISCLOSED, REPRODUCED IN WHOLE OR IN PART OR USED FOR MANUFACTURING PURPOSES BY ANYONE WITHOUT THE CONSENT OF CARLING TECHNOLOGIES, INC.

DISCLAIMER
MANUFACTURER RESERVES THE RIGHT TO CHANGE PRODUCT SPECIFICATIONS WITHOUT PRIOR NOTICE.

**A-SERIES
CIRCUIT_BREAKER**

DO NOT SCALE DRAWING
UNLESS OTHERWISE SPECIFIED
DIMENSIONS: IN [MM]
TOLERANCES: ± .020 [0.51]

DRAWING FILE NO. AA1-B0-34-620-5D1-C SIZE C
PRODUCT SERIES: A-SERIES C.B. SHEET 1 OF 1