

REV	DESCRPT	DATE	APPRVD
C	DUST COVER DWG NO. CHANGED	MAY15,07	AG
D	DIMENSIONS ADDED	OCT.19,07	AG

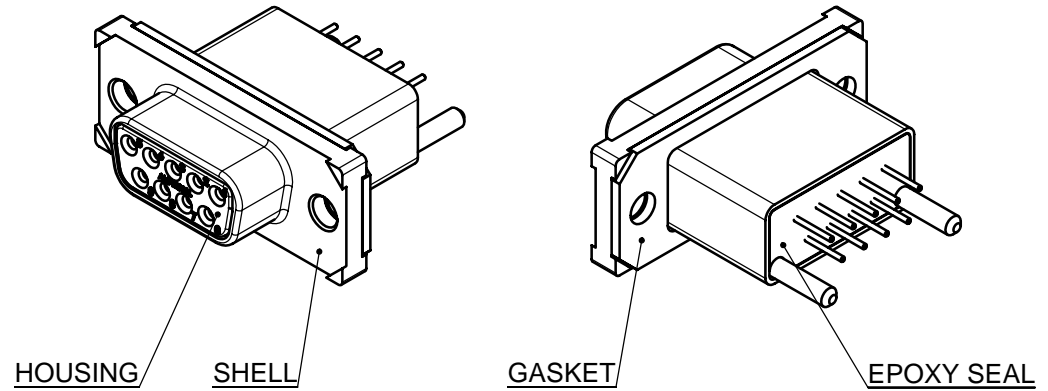

MDB-E09SA-765 IS SHOWN

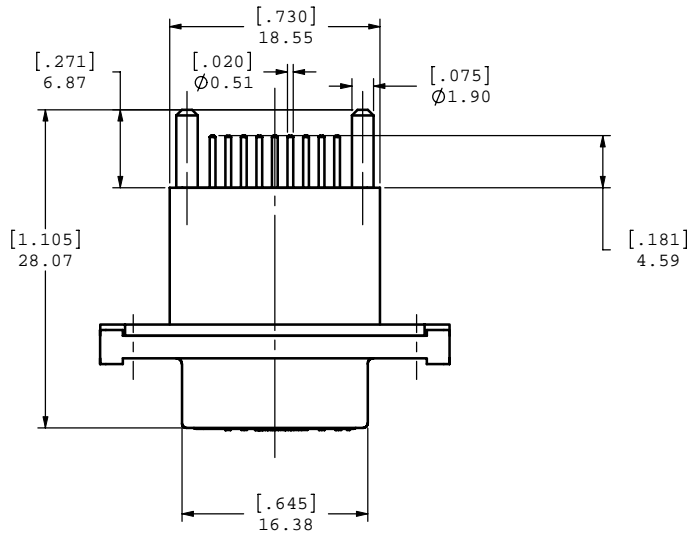
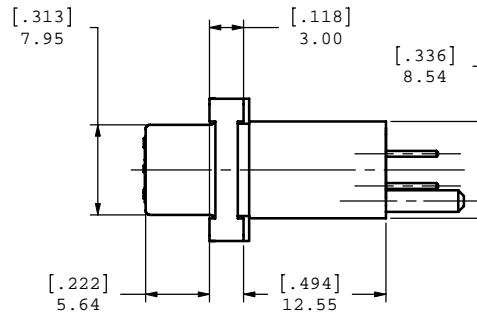
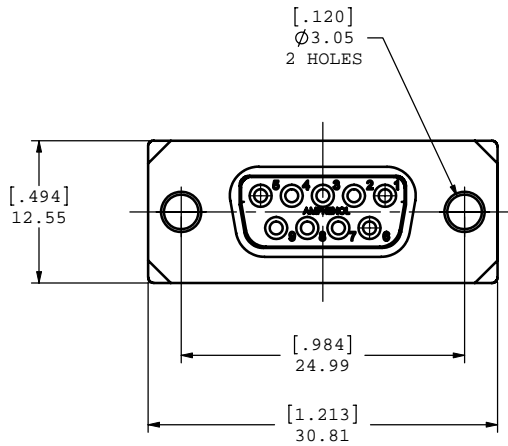

NOTES:

1. MATERIAL:
 - SHELL: ZINC ALLOY WITH 50 MICRO INCH MINIMUM NICKEL PLATING,
 - CONTACTS: COPPER ALLOY 50 MICRO INCH GOLD OVER 50 MICRO INCH NICKEL PLATING,
 - HOUSING: THERMOPLASTIC POLYESTER RESIN,
 - GASKET: SILICONE RUBBER,
 - SCREWS: STAINLESS STEEL,
 - DUST COVER: SILICONE RUBBER.
2. FEATURES: SEALED CONNECTOR IN THE MATED AND UNMATED CONDITIONS.
3. OPERATING TEMPERATURE: -40°C TO +105°C.
4. ENVIRONMENT PERFORMANCE: IP67.
5. CONNECTOR IS ROHS COMPLIANT PER EU DIRECTIVE 2002/95/EC AND AMENDMENTS.
6. PART IS UL94V-0 FLAMMABILITY COMPLIANT.
7. PART NUMBER FOR ORDER:
 - MDB-E09SA-760 - WITH DUST COVER AND SCREWS,
 - MDB-E09SA-765 - NO DUST COVER AND SCREWS.



UNLESS OTHERWISE SPECIFIED DIMENSIONS ARE IN MILLIMETER TOLERANCES ARE:		APPROVALS	DATE	Amphenol Canada Corp.	
DECIMALS	ANGLES	DRAWN	OCT02/06		
.XX ±.10	± 1°	S.SEMENOV		TITLE	RUGGED 9 SOKET, D-SUB CONNECTOR, VERTICAL MOUNT
X ±.25		DESIGNED	OCT02/06	SIZE	C
MATERIAL AND FINISH		S.SEMENOV		DWG. NO.	P-MDB-E09SA-76X
		CHECKED		REV.	D
		QA APP'D		SCALE	3:1
		IE APP'D		PROJECT	MDB
REF.		DWG APP'D	OCT02/06	SHEET	1 OF 2
CODE IDENT. NO.		A.GREEN			

DO NOT SCALE DRAWING
THIS DOCUMENT CONTAINS PROPRIETARY INFORMATION AND SUCH INFORMATION MAY NOT BE DISCLOSED TO OTHERS FOR ANY PURPOSE OR USED FOR MANUFACTURING PURPOSES WITHOUT PERMISSION FROM AMPHENOL CANADA CORP.

REV	-	DESCRIPT	-	DATE	-	APPRVD
C		DUST COVER DWG NO. CHANGED		MAY15,07		AG
D		DIMENSIONS ADDED		OCT.19,07		AG

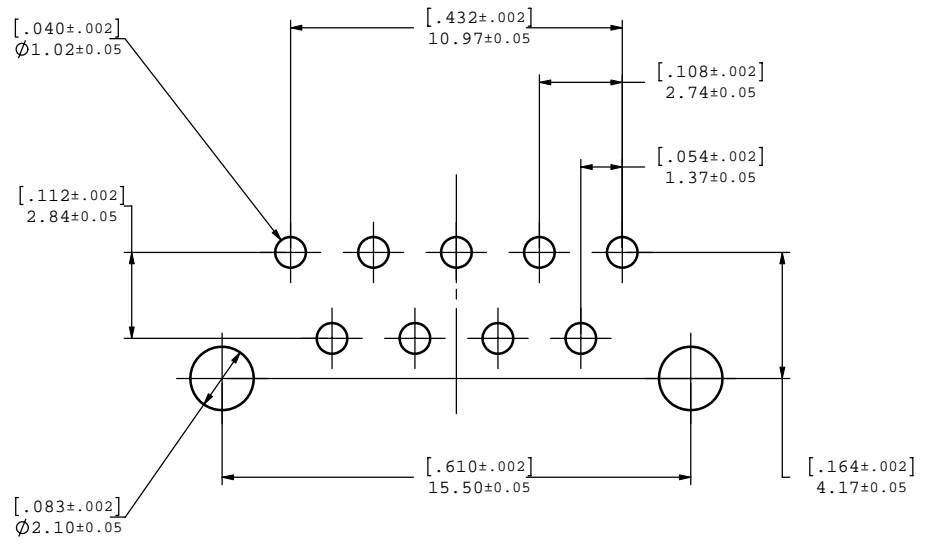

RECOMMENDED P.C.B. LAYOUT

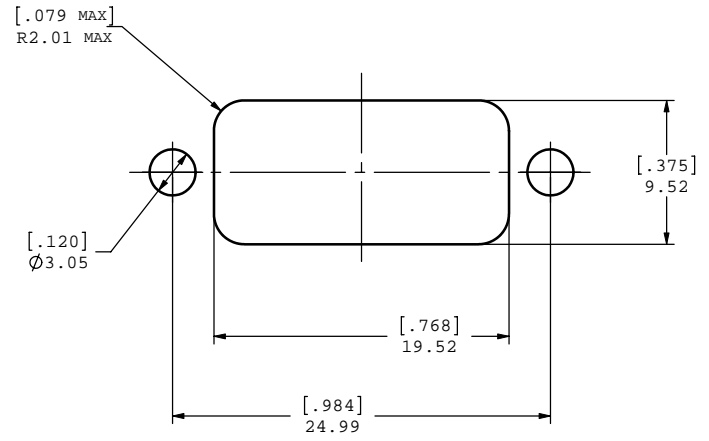

RECOMMENDED PANEL CUTOUT DIMENSIONS FOR REFERENCE ONLY

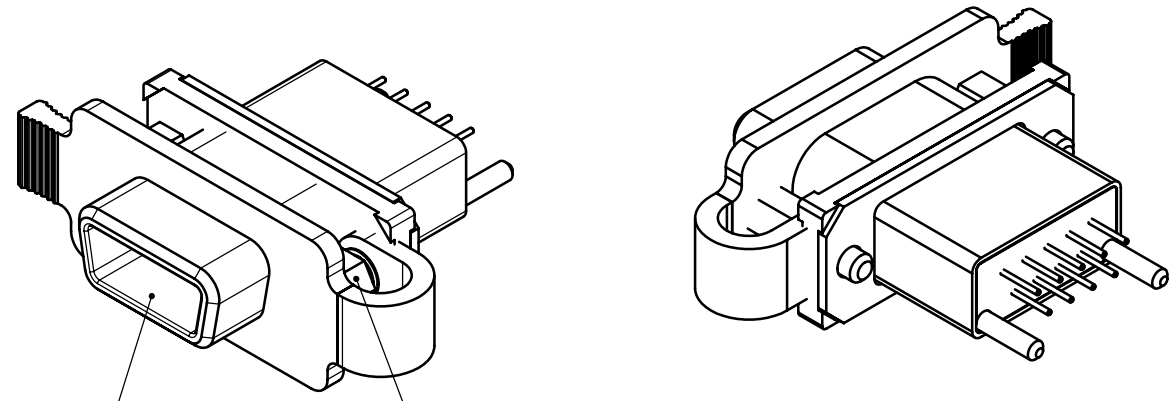

DUST COVER

SCREW

MDB-E09SA-760 IS SHOWN

FOR MORE INFORMATION ABOUT DUST COVER, SEE DRAWING P-MDB-227-093-205BP



UNLESS OTHERWISE SPECIFIED DIMENSIONS ARE IN MILLIMETER TOLERANCES ARE:		APPROVALS	DATE	Amphenol Canada Corp.	
DECIMALS	ANGLES	DRAWN	OCT02/06		
.XX ±.10	± 1°	S.SEMENOV		TITLE	RUGGED 9 SOKET, D-SUB CONNECTOR, VERTICAL MOUNT
.X ±.25		DESIGNED	OCT02/06	SIZE	
MATERIAL AND FINISH		CHECKED		C	DWG. NO.
		QA APP'D			P-MDB-E09SA-76X
REF.		IE APP'D			REV.
CODE IDENT. NO.		DWG APP'D	OCT02/06	A.GREEN	D
					SCALE
					3:1
					PROJECT
					MDB
					SHEET
					2 OF 2

DO NOT SCALE DRAWING
THIS DOCUMENT CONTAINS PROPRIETARY INFORMATION AND SUCH INFORMATION MAY NOT BE DISCLOSED TO OTHERS FOR ANY PURPOSE OR USED FOR MANUFACTURING PURPOSES WITHOUT PERMISSION FROM AMPHENOL CANADA CORP.