

THIS DRAWING IS UNPUBLISHED. RELEASED FOR PUBLICATION
 BY AMP INCORPORATED. ALL RIGHTS RESERVED.

| LOC | DIST | REVISIONS | | | |
|-----|------|-------------|-----------------------------|---------|-------|
| P | LTR | DESCRIPTION | DATE | DWN | APVD |
| AA | 22 | A | REVISED PER EC 0515-0123-03 | 11APR03 | DD EL |

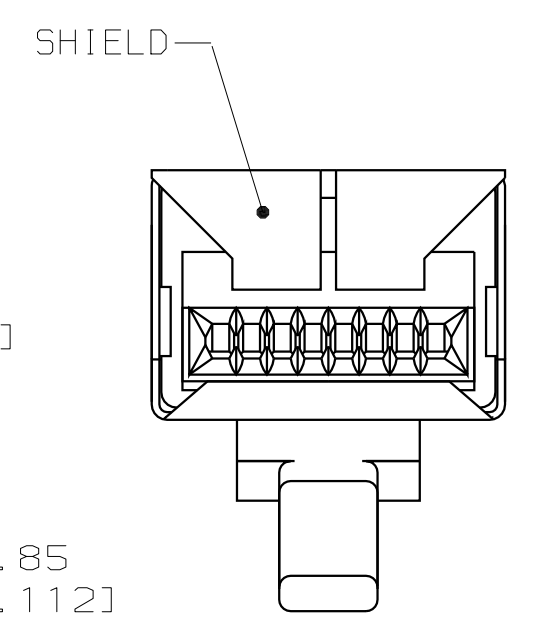
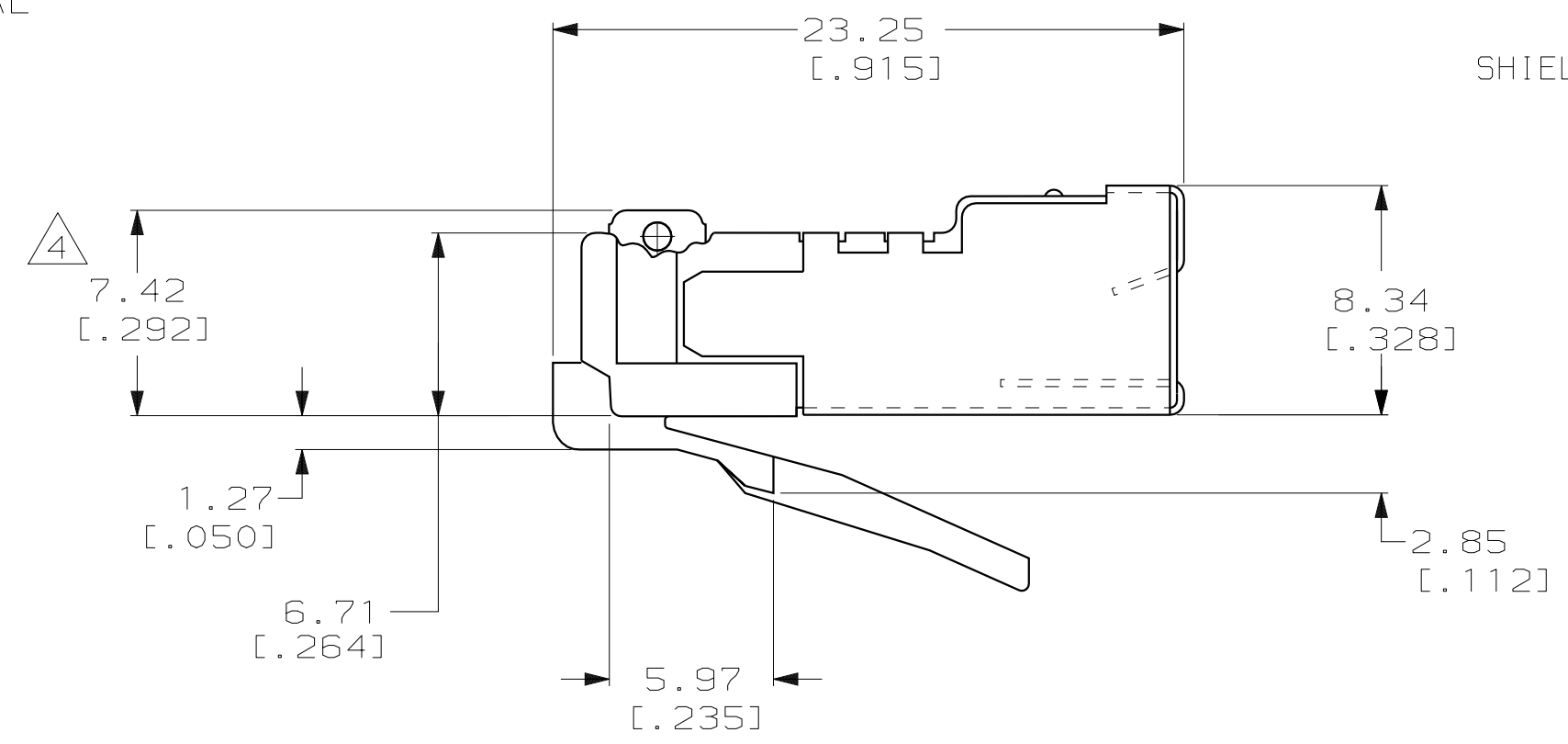
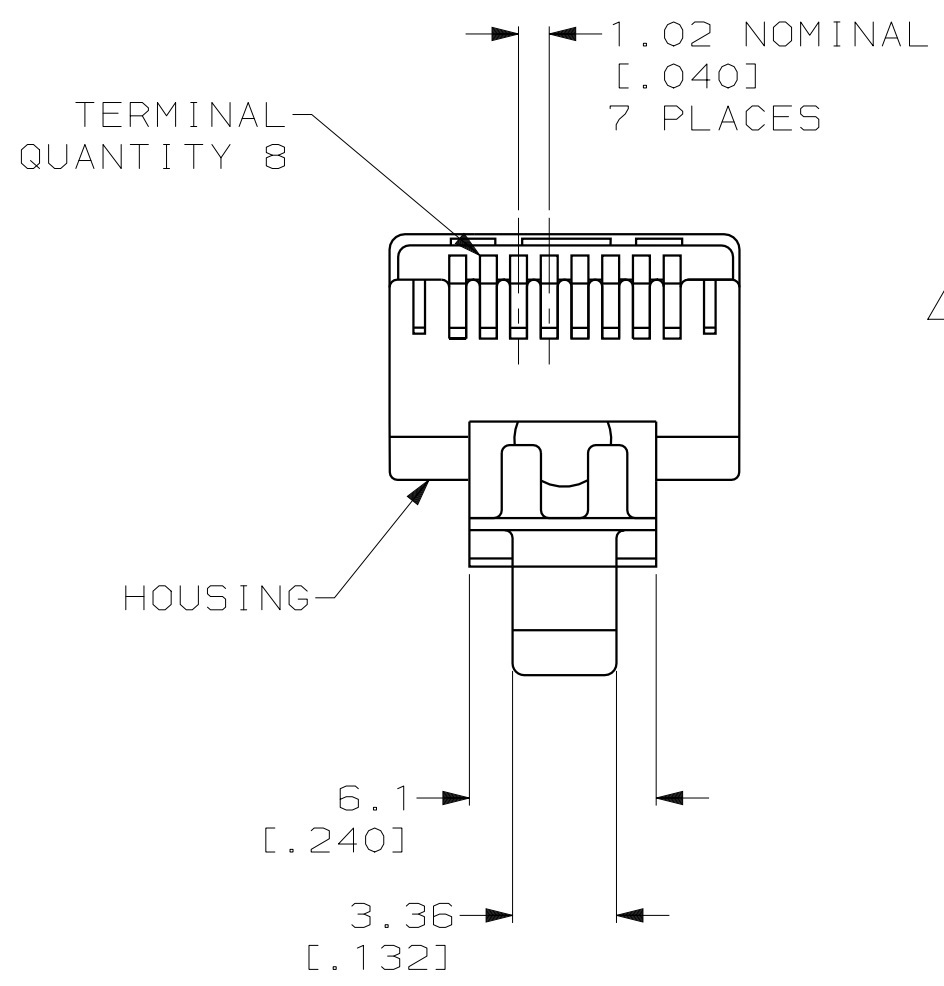
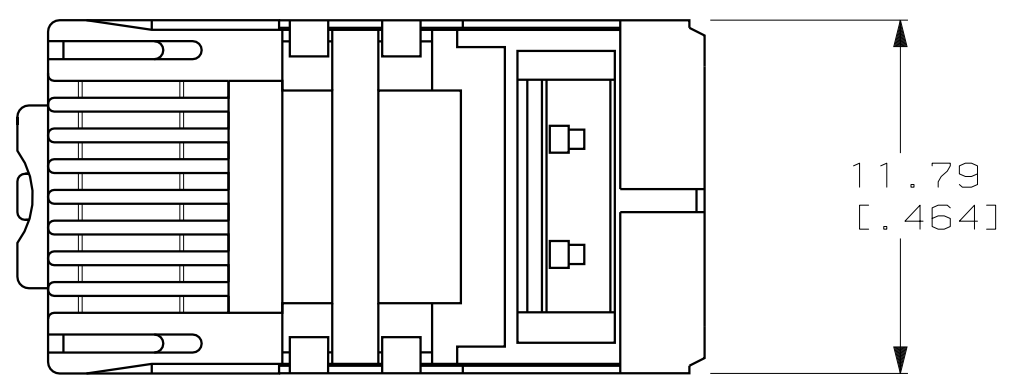
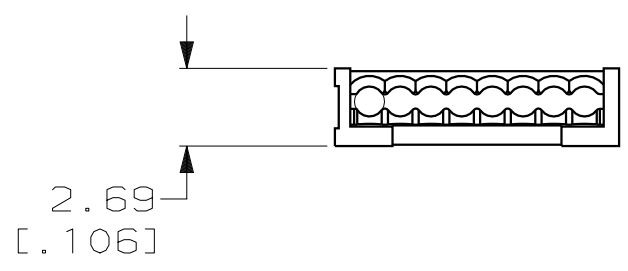
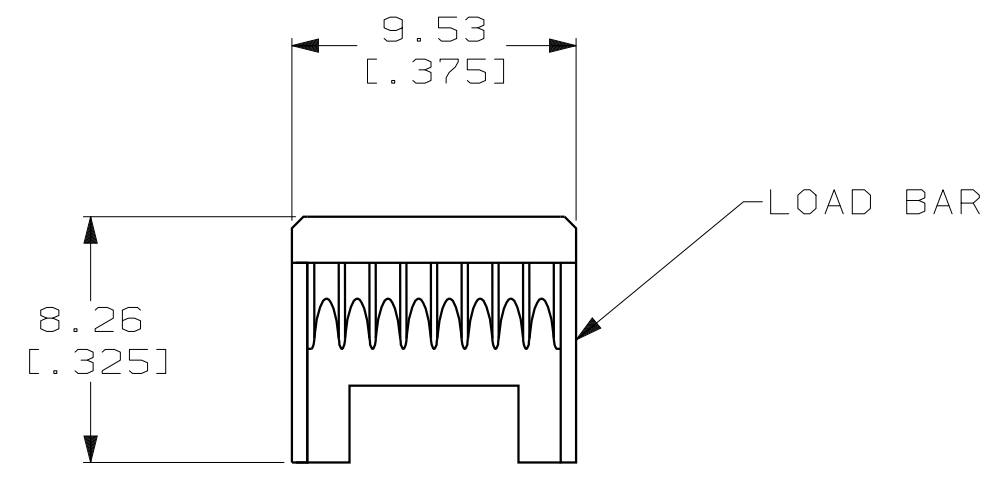

- 1 DIMENSIONS ARE MAXIMUM UNLESS OTHERWISE SPECIFIED.
- 2 MATERIAL: HOUSING - POLYCARBONATE, CLEAR
 TERMINAL - PHOSPHOR BRONZE, PLATED WITH 1.27µm [.000050] MINIMUM THICK GOLD IN LOCALIZED GOLD PLATE AREA, GOLD FLASH OVER THE REMAINDER, OVER 2.54µm [.000100] MINIMUM THICK NICKEL UNDERPLATE.
 SHIELD - COPPER ALLOY WITH 1.27µm [.000050] MINIMUM SEMI-BRIGHT (SATIN) NICKEL.
 LOAD BAR - PBT POLYESTER, BLACK.
- 3. PLUG WILL ACCEPT A 24 OR 26 AWG STRANDED CONDUCTOR, PROVIDED THE INSULATED CONDUCTOR DIAMETER IS 0.89 [.035] TO 0.99 [.039] WITH A SHIELDED, PLIABLE, LOOSE CABLE JACKET OF 4.83 [.190] TO 5.21 [.205] DIAMETER OR A SHIELDED, RIGID, HARD CABLE JACKET OF 4.83 [.190] TO 5.08 [.200] DIAMETER.
- 4 TERMINATED DIMENSION 6.15 [.242] MAXIMUM.
- 5 PACKAGED 500 ASSEMBLIES AND 500 LOAD BARS PER CARTON.
- 6 PACKAGED 100 ASSEMBLIES AND 100 LOAD BARS PER BOX.
- 7 PACKAGED 25 ASSEMBLIES AND 25 LOAD BARS PER BAG.

LEAD FREE

| | |
|----------|-------------|
| 7 | 5-569552-4 |
| 6 | 5-569552-3 |
| 5 | 5-569552-2 |
| PACKAGED | PART NUMBER |

| | | | |
|---|--|---|--|
| THIS DRAWING IS A CONTROLLED DOCUMENT FOR AMP INCORPORATED. IT IS SUBJECT TO CHANGE AND THE CONTROLLING ENGINEERING ORGANIZATION SHOULD BE CONTACTED FOR THE LATEST REVISION. | | DWN G. GARRETT 10-12-95 | AMP AMP Incorporated Harrisburg, PA 17105-3608 |
| DIMENSIONS: mm [INCHES] | | CHK C. WHITT 10-31-95 | |
| TOLERANCES UNLESS OTHERWISE SPECIFIED: | | APVD E. LAURER 11-7-95 | |
| 0 PLC ±- 1 PLC ±- 2 PLC ±- 3 PLC ±- 4 PLC ±- ANGLES ±- FINISH ±- | | NAME PRODUCT SPEC 108-1163 APPLICATION SPEC 114-6053 WEIGHT - CUSTOMER DRAWING | |
| MATERIAL | | SIZE A2 | CAGE CODE 00779 |
| | | DRAWING NO C-569552 | SCALE 4:1 |
| | | SHEET 1 OF 1 | REV A |