

STANDARD CRIMP

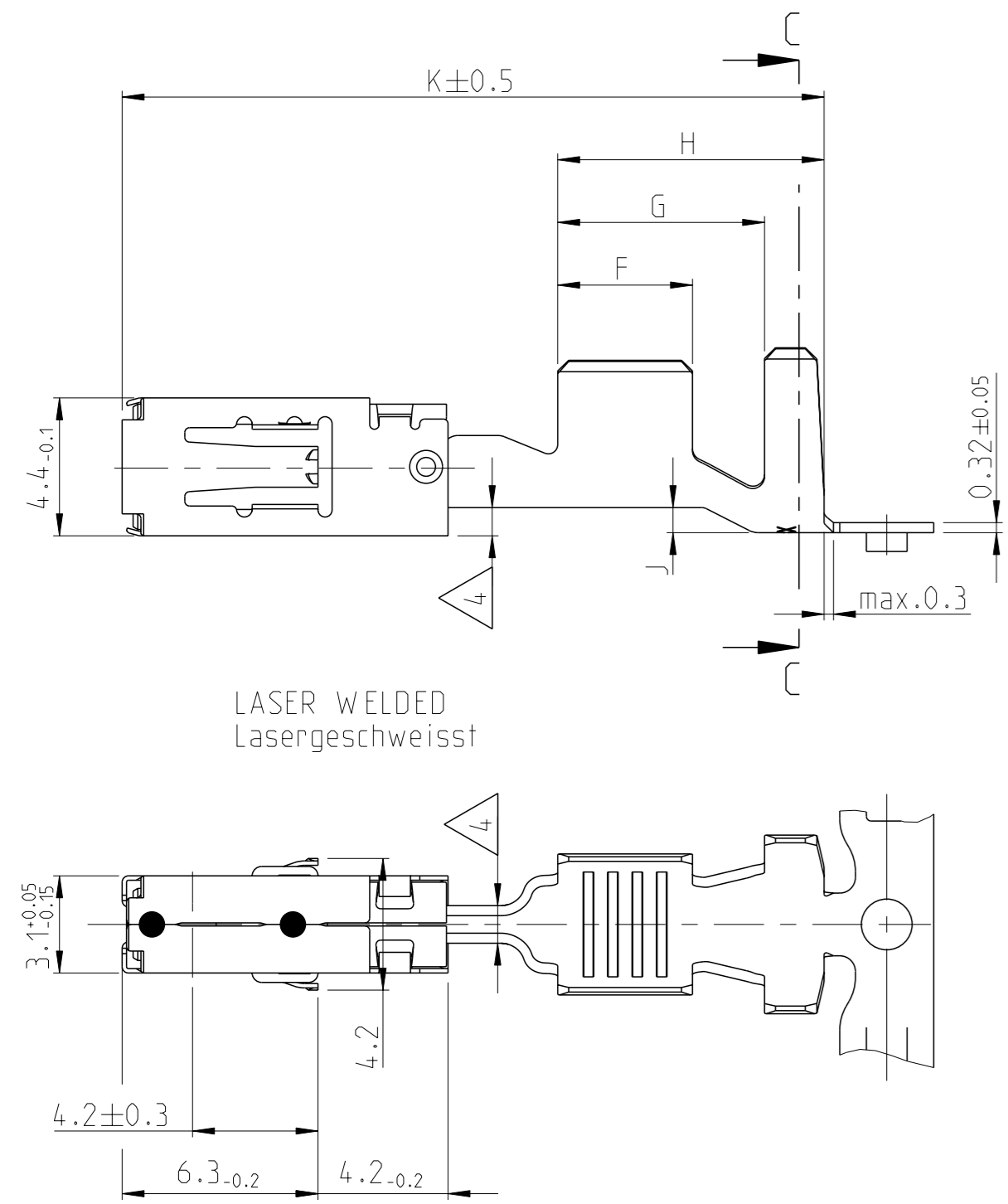

ONLY FOR WIRE SIZE RANGE
Nur fuer DGB
0.2 ... 0.5 mm²

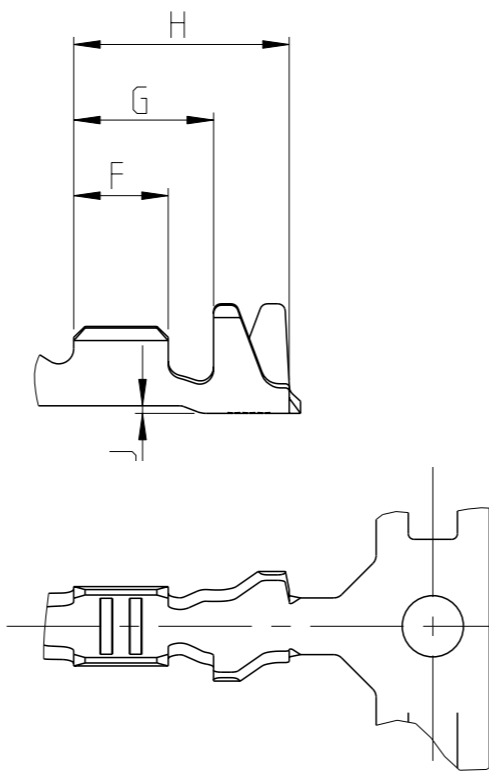

SINGLE WIRE SEAL Einzeldichtungssystem

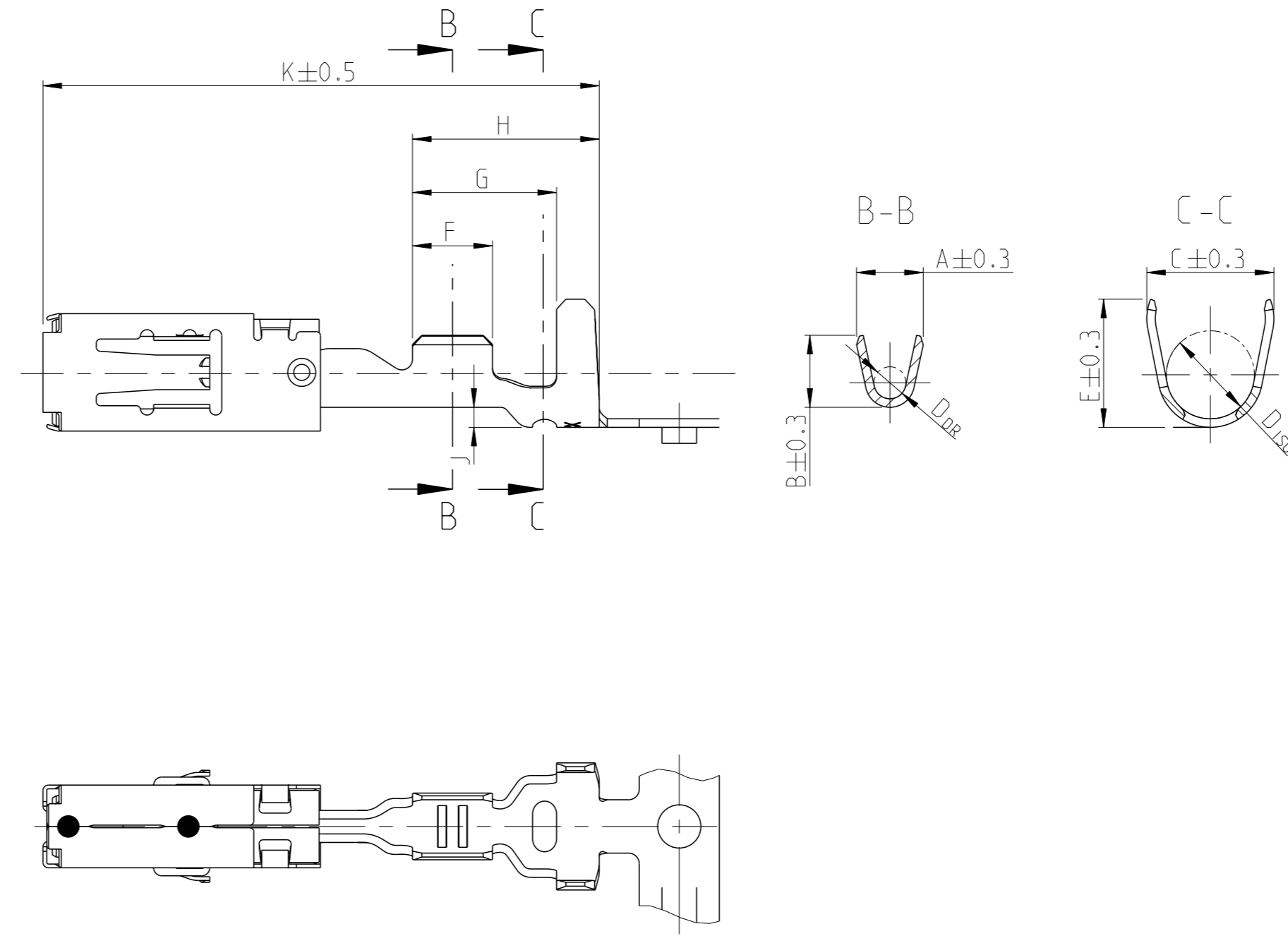

REVISIONS				
#	DATE	DESCRIPTION	DATE	APPROVED
J8		DRAWING MISTAKE CORRECTED ECR-14-001420	30JAN2014	Abt Leim
J9		DRAWING MISTAKE CORRECTED ECR-14-003309	05MAR2014	Bren Leim
J10		ECR-14-010789	18JUL2014	Joas Leim
J11		NOTE 8 ADDED. TABLE UPDATE WITH PNs 1-...-4	17MAY2017	MAH. SBEC

VERSION	Ausfuhrung	ORDER-NO. STRIP-FORM	Bestell-Nr. Bandware	REV	MATERIAL	BODY	SPRING	SURFACE	WIRE SIZE RANGE	INSULATION DIAMETER	CRIMP DIMENSIONS / Crimpabmessungen mm											WEIGHT	SINGLE WIRE SEAL	TE CONNECTIVITY NO.	APPLICATION TOOLS			
											A	B	D _{DR}	C	E	D _{ISO}	F	G	H	J	K					g		
									12 AWG	3.0 - 3.8	4.0	4.2	2.0	5.0	5.0	3.5	3.5	5.9	7.5	0.8	21.0	0.59	828905-1	828922-1				
									4	3.4 - 3.7	4.5	4.7	2.3	6.0	6.0	4.3	4.3	6.9	8.5	1.25	22.6	0.65	828985-1	828986-1				
									1.5 - 2.5	2.2 - 3.0	3.6	3.8	1.7	5.0	5.0	3.5	3.5	5.9	7.5	0.8	21.0	0.58	828905-1	828922-1				
									0.5 - 1.0	1.4 - 2.1	2.5	2.7	1.2	4.8	4.8	3.0	3.0	5.4	7.0	0.75	21.0	0.54	828904-1	828922-1				
									0.2 - 0.5	1.2 - 1.4	2.1	2.1	0.8	4.5	4.5	3.2	2.5	4.9	6.5	0.75	21.0	0.52	828904-1	828922-1				
									4	2.7 - 3.7	4.5	4.7	2.3	5.7	5.9	3.3	4.3	6.6	8.5	0.8	22.6	0.65	-	-				
									1.5 - 2.5	2.2 - 3.0	3.6	3.8	1.7	4.6	4.8	2.6	3.5	5.1	6.7	0.3	20.2	0.56	-	-				
									0.5 - 1.0	1.4 - 2.1	2.5	2.7	1.2	3.3	3.5	1.8	3.0	4.6	6.2	0.2	20.2	0.51	-	-				
									0.2 - 0.5	1.2 - 1.4	2.1	2.1	0.8	2.9	2.9	1.4	2.5	3.7	5.7	0.2	20.2	0.48	-	-				

SEE APPLICATION SPECIFICATION 114-18148
siehe Verarbeitungsspezifikation 114-18148

NOTES:
Bemerkungen:

- MATING PART SEE INTERFACE DRAWING
TE-NO.: 114-18230-002
Gegenstecker nach Ausfuhrungsvorschrift
TE-Nr.: 114-18230-002
- SURFACE:**
- PRE TIN PLATED 1 TO 3 µm
- GOLD PLATED MIN. 2 µm (ONLY CONTACT AREA)
- SILVER PLATED 3 TO 5 µm (ONLY CONTACT AREA)
Oberflaeche:
- verzinkt 1 bis 3 µm
- vergoldet min. 2 µm (nur Kontaktzone)
- versilbert 3 bis 5 µm (nur Kontaktzone)
- DOUBLE CRIMPS ARE ONLY POSSIBLE WITH APPLICATORS AUTHORIZED BY TE (NO HAND TOOL) SUITABLE TOOLS ON REQUEST
Doppelanschlaege sind nur mit von TE zugelassenen Anschlagwerkzeugen moeglich (keine Handzangen) passende Werkzeuge auf Anfrage
- GAUGE INSPECTION**
Lehrenpruefung
- DETAILS OF DESIGN ARE LEFT TO MANUFACTURER
Einzelheiten der Ausfuhrung bleiben dem Hersteller ueberlassen
- ONLY GERMAN LANGUAGE VERSION SHALL BE BINDING
Massgebend ist der deutsche Text
- PUNCHING OIL RAZIOL CLF 11 SG
Stanzool:
- J11** 1-...-4 NOT TO BE USED FOR NEW APPLICATIONS. SUPERSEDED BY 1-...-3
1-...-4 nicht fuer Neuanwendungen benutzen. Ersetzt durch 1-...-3

THIS DRAWING IS A CONTROLLED DOCUMENT.		OWN S. Blidar	ZZSEP97	TE TE Connectivity	
DIMENSIONS: mm		CHK G. Hotea	22SEP97		
TOLERANCES UNLESS OTHERWISE SPECIFIED: ±0.2		APVD J. Woller	ZZSEP97	NAME PRODUCT GROUP DRAWING FOR Tabellenzeichnung fuer AMP MCP 2.8	
MATERIAL		108-18513	APPLICATION SPEC	SIZE 114-18148	
FINISH		114-18148	WEIGHT	SCALE 5:1 SHEET 1 OF 1 REV J11	
CUSTOMER DRAWING		CAGE CODE DRAWING NO. 00779		RESTRICTED TO	