

THIS DRAWING IS UNPUBLISHED. RELEASED FOR PUBLICATION 20
 © COPYRIGHT 20 BY - ALL RIGHTS RESERVED.

LOC		DIST		REVISIONS			
P	LTR	DESCRIPTION	DATE	DWN	APVD		
A7		REVISED PER ECR-16-006606	10MAY2016	RS	DD		
A8		REVISED PER ECR-16-012107	25AUG2016	RS	PO		
A9		REVISED PER ECR-16-014606	18OCT2016	RK	ASM		
A10		REVISED PER ECR-17-014440	04OCT2017	RK	DD		

- 10 PRELIMINARY.
- 11 FOR PART NUMBER 5-2213362-4 ONLY, STRIP AND REMOVE INSULATION AS SHOWN. LEAD WIRES TO BE SOLDER DIPPED.

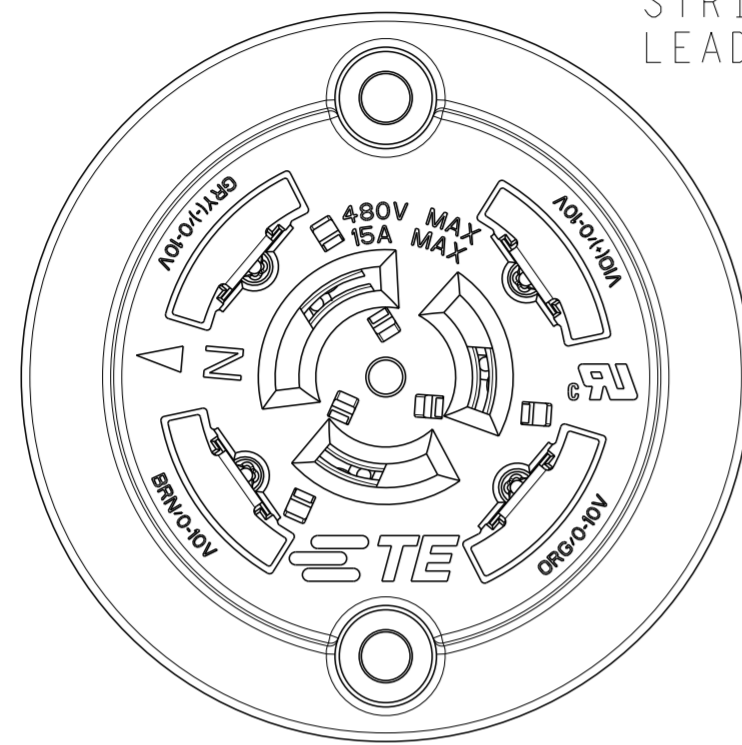

SEE SHEET 2 FOR WIRING COLOR CODE

NOTES:

- 1. MATERIALS:
HOUSING: GLASS-FILLED THERMOPLASTIC, UL 94V-0 RATED DIMMING CONTACTS (2 OR 4) AND LINE VOLTAGE CONTACTS (3): COPPER ALLOY
- 2. FINISH:
DIMMING CONTACTS (2 OR 4): NICKEL UNDERPLATE ENTIRE CONTACT 0.127 µm MIN THICK. GOLD PLATE CONTACT PAD AREA (MATING FACE SIDE ONLY) 0.76 µm MIN THICK. MATTE TIN PLATE TAB ON BOTH SIDES 0.30 µm MIN THICK. LINE VOLTAGE CONTACTS (3): TIN PLATE.
- 3. LINE VOLTAGE CONDUCTORS (3):
14 AWG, 600V, 150°C RATED, COPPER 41/30 STRANDED PER UL STYLE AWM 3321.
- 4. MATING INTERFACE PER ANSI C136.41-2013.
- 5. OPTIONAL DIMMING CONTACTS (2) SUPPLIED.
- 6. DIMMING CONDUCTORS (2 OR 4):
18 AWG, 600V, 150°C RATED, 16/30 STRANDED, PER UL STYLE AWM 3321.
- 7. LINE VOLTAGE CONDUCTORS (3):
14 AWG, 600V, 105°C RATED, COPPER 41/30 STRANDED. PER UL STYLE AWM 1015.
- 8. DIMMING CONDUCTORS (2 OR 4):
18 AWG, 600V, 105°C RATED, COPPER 16/30 STRANDED. PER UL STYLE AWM 1015.
- 9. LUBRICATION: GOLD PLATED CONTACT PAD SURFACES OF DIMMING CONTACTS ARE LUBRICATED WITH A TRANSPARENT (NON-VISIBLE) LUBRICANT TO IMPROVE DURABILITY AND PERFORMANCE. AVOID CONTACT WITH THESE SURFACES WHICH MAY RESULT IN REMOVAL OF LUBRICANT.

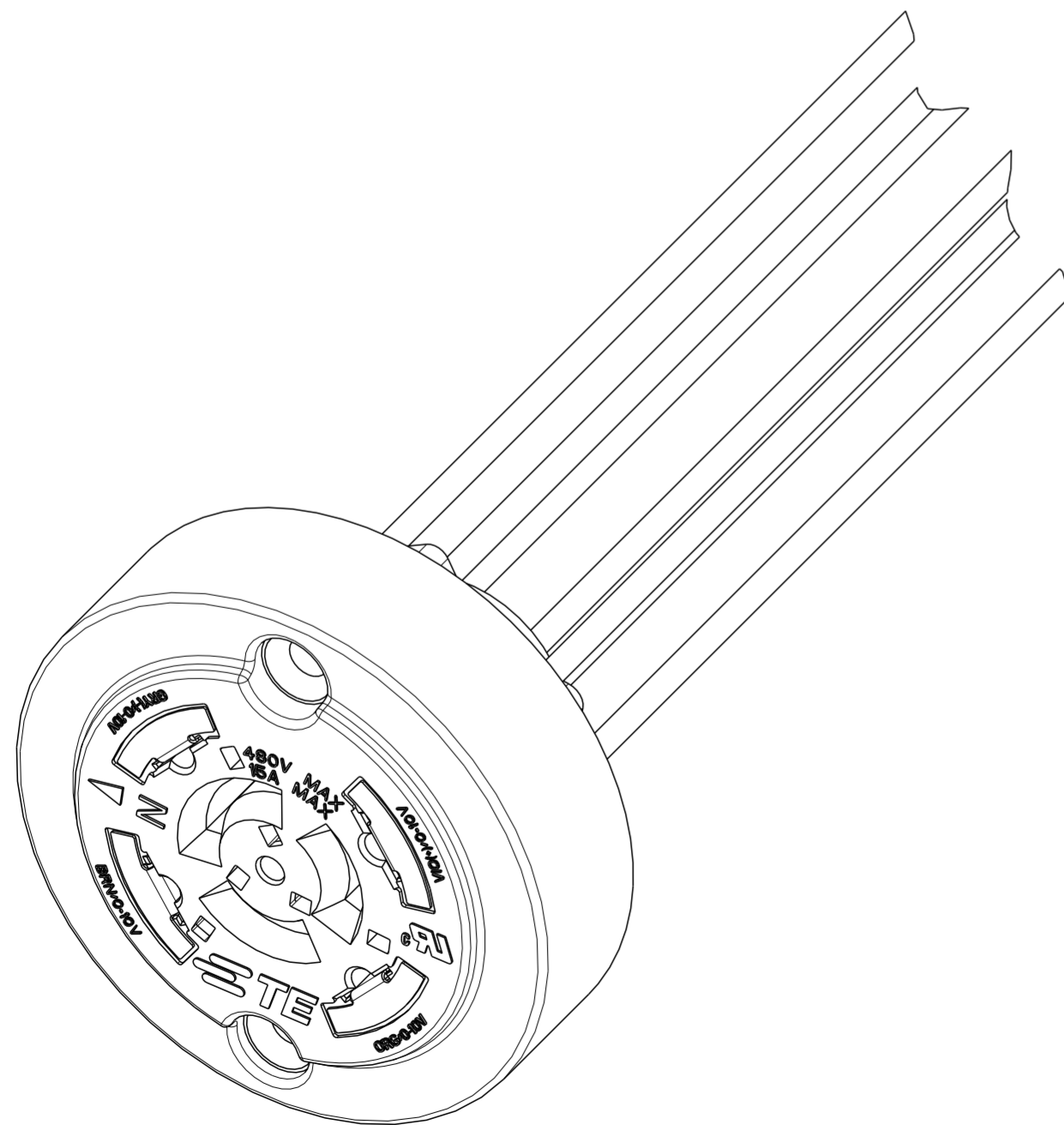

341.1	304.8	291.3	7 AND 8	4 5	5-2213362-4 1 10
950.7	914.4	914.4	7 AND 8	4 5	4-2213362-4 10
73.0	35.0	35.0	7 AND 8	4 5	3-2213362-4 10
1865.1	1828.8	1815.3	3 AND 6	2	3-2213362-1 10
736.3	700.0	686.5	7 AND 8	4 5	2-2213362-4
696.3	660.0	646.5	3 AND 6	4 5	2-2213362-2 10
696.3	660.0	646.5	3 AND 6	2	2-2213362-1
536.3	500.0	486.5	7 AND 8	4 5	1-2213362-4
536.3	500.0	486.5	7 AND 8	2	1-2213362-3 10
536.3	500.0	486.5	3 AND 6	2	1-2213362-1 10
341.1	304.8	291.3	7 AND 8	4 5	2213362-4
341.1	304.8	291.3	7 AND 8	2	2213362-3
341.1	304.8	291.3	3 AND 6	4 5	2213362-2
341.1	304.8	291.3	3 AND 6	2	2213362-1
C	A	B	WIRE STYLE	QUANTITY OF DIMMING CONTACTS	PART NO.
OVERALL LENGTH	WIRE LENGTH				

THIS DRAWING IS A CONTROLLED DOCUMENT.

DWN	J. SHAFFER	26 JUN 2013
CHK	E. HOWARD	26 JUN 2013
APVD	E. HOWARD	26 JUN 2013

STE TE Connectivity

NAME: RECEPTACLE ASSEMBLY, DIMMABLE PHOTOCONTROL

PRODUCT SPEC: 108-32059

APPLICATION SPEC: 114-32115

SIZE: A2 CAGE CODE: 00779 DRAWING NO: C-2213362

RESTRICTED TO: -

CUSTOMER DRAWING SCALE: 1:1 SHEET 1 OF 2 REV: A10

THIS DRAWING IS UNPUBLISHED. RELEASED FOR PUBLICATION 20
 © COPYRIGHT 20 BY - ALL RIGHTS RESERVED.

LOC		DIST		REVISIONS				
P	LTR	DESCRIPTION		DATE	DWN	APVD		
-	-	SEE SHEET 1		-	-	-		

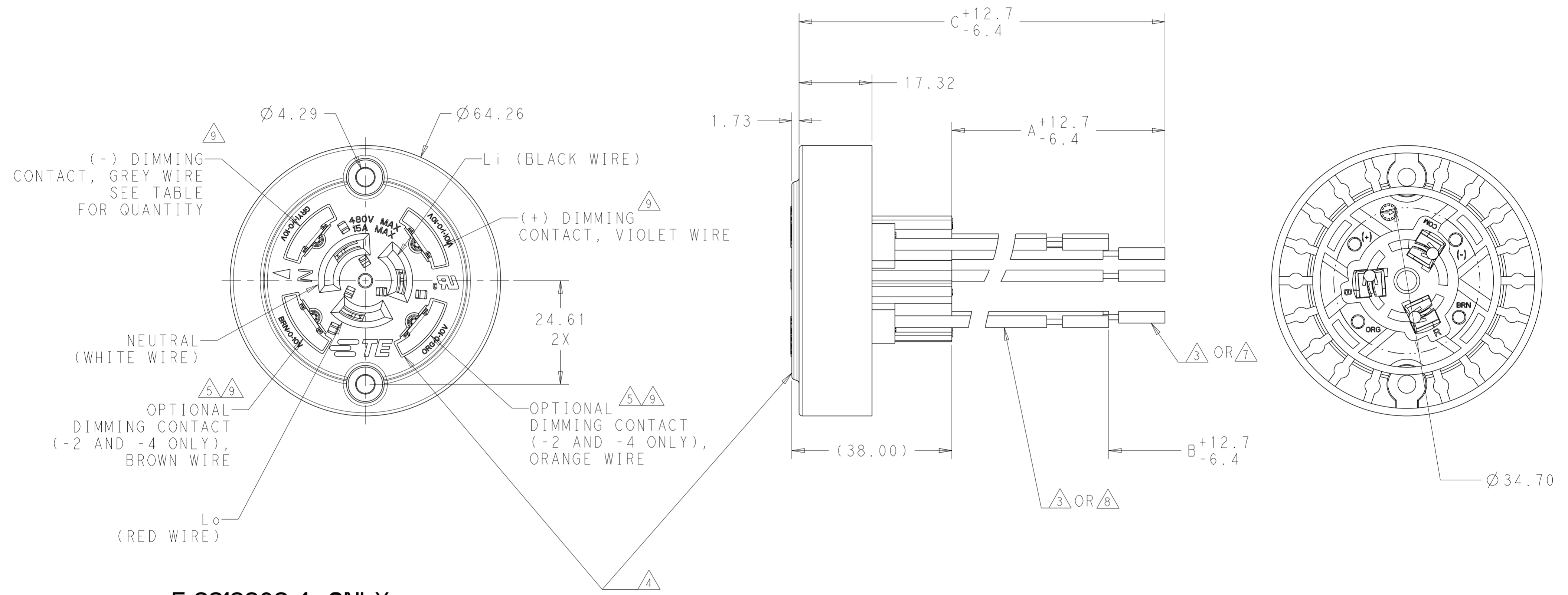

5-2213362-4 ONLY

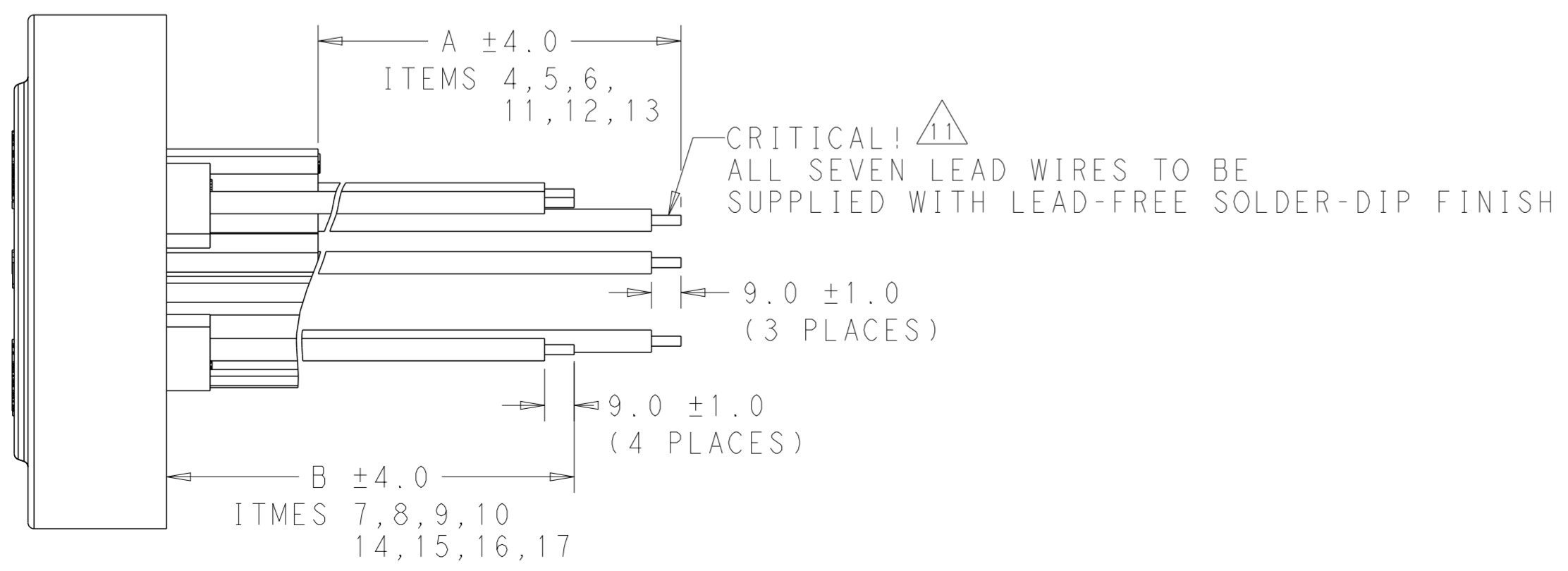

THIS DRAWING IS A CONTROLLED DOCUMENT.		DWN J. SHAFFER 26 JUN 2013	 TE Connectivity	
DIMENSIONS: mm		CHK E. HOWARD 26 JUN 2013		
TOLERANCES UNLESS OTHERWISE SPECIFIED: 0 PLC ± 1 PLC ± 2 PLC ±0.13 3 PLC ± 4 PLC ± ANGLES ± FINISH		APVD E. HOWARD 26 JUN 2013	NAME RECEPTACLE ASSEMBLY, DIMMABLE PHOTOCONTROL	
MATERIAL		PRODUCT SPEC 108-32059	SIZE A200779	CAGE CODE C-2213362
		APPLICATION SPEC 114-32115	DRAWING NO. C-2213362	RESTRICTED TO
		WEIGHT	SCALE 1:1 SHEET 2 OF 2 REV A10	
		CUSTOMER DRAWING		