

PART NUMBERING	LOADING PATTERN				PACKAGING (SEE NOTE 6)	REMARK
	COLUMN 1 (NOTE 4)	COLUMN 2	COLUMN 3	COLUMN 4		
10044471-120200LF	UNSHIELDED IMLA	EMPTY	UNSHIELDED IMLA	EMPTY	TAPE ON REEL	
10044471-122220LF	UNSHIELDED IMLA	UNSHIELDED IMLA	UNSHIELDED IMLA	UNSHIELDED IMLA	TAPE ON REEL	
10044471-121110LF	UNSHIELDED IMLA	SHIELDED IMLA	SHIELDED IMLA	SHIELDED IMLA	TAPE ON REEL	
10044471-120200ELF	UNSHIELDED IMLA	EMPTY	UNSHIELDED IMLA	EMPTY	TAPE ON REEL	
10044471-122220ELF	UNSHIELDED IMLA	UNSHIELDED IMLA	UNSHIELDED IMLA	UNSHIELDED IMLA	TAPE ON REEL	CUSTOMIZED LABEL FOR SPECIAL P/NS
10044471-121110ELF	UNSHIELDED IMLA	SHIELDED IMLA	SHIELDED IMLA	SHIELDED IMLA	TAPE ON REEL	

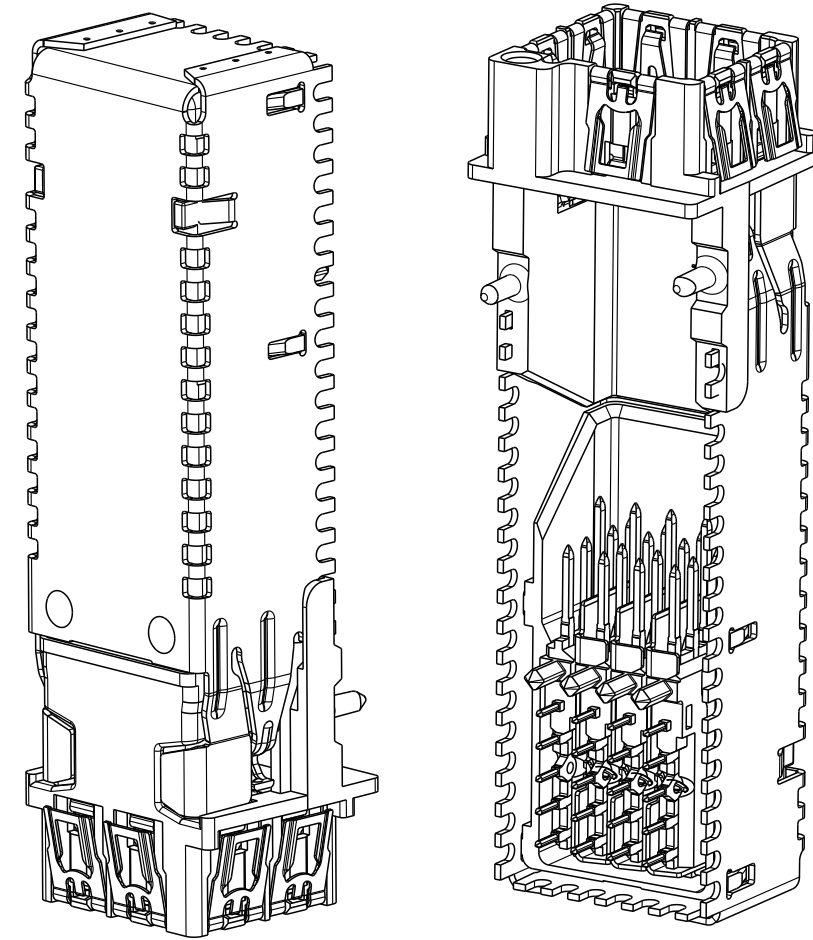

COLUMN: 1 2 3 4

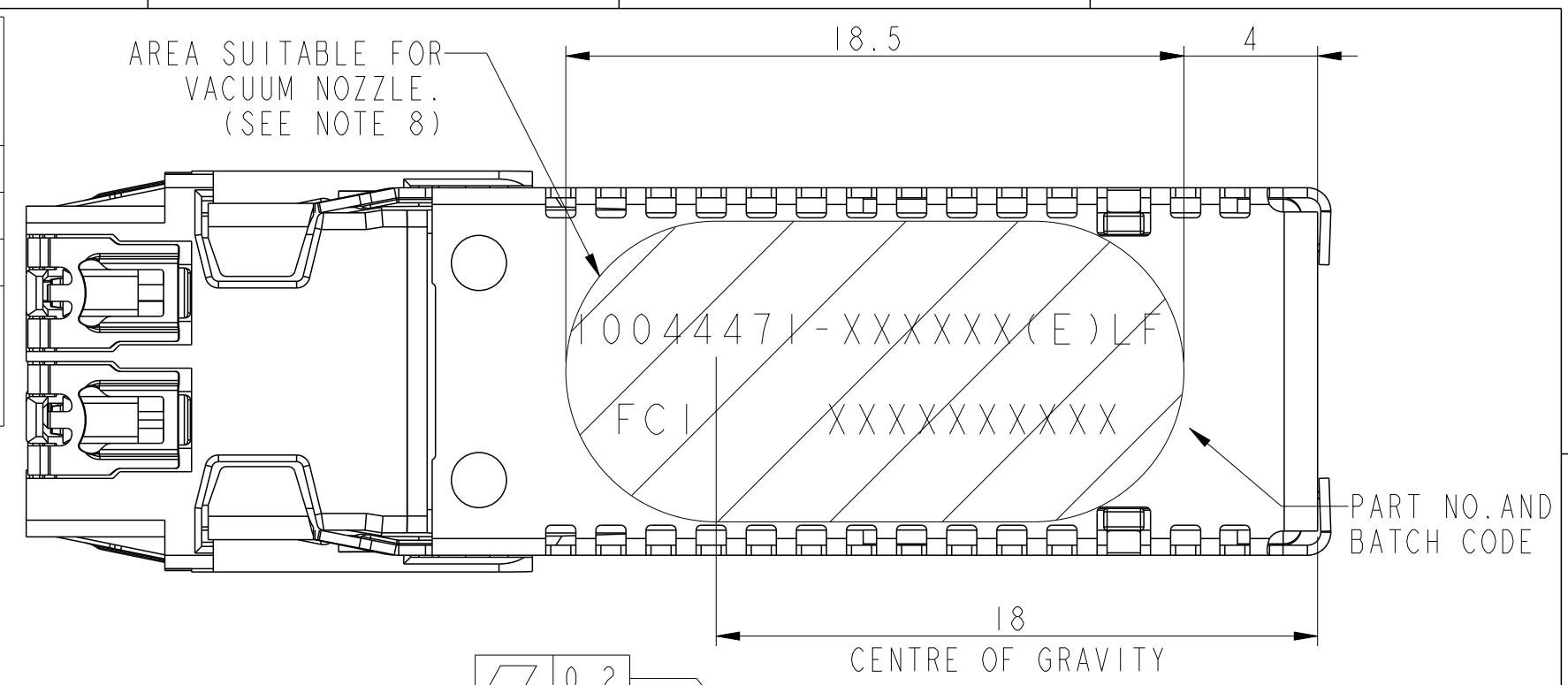
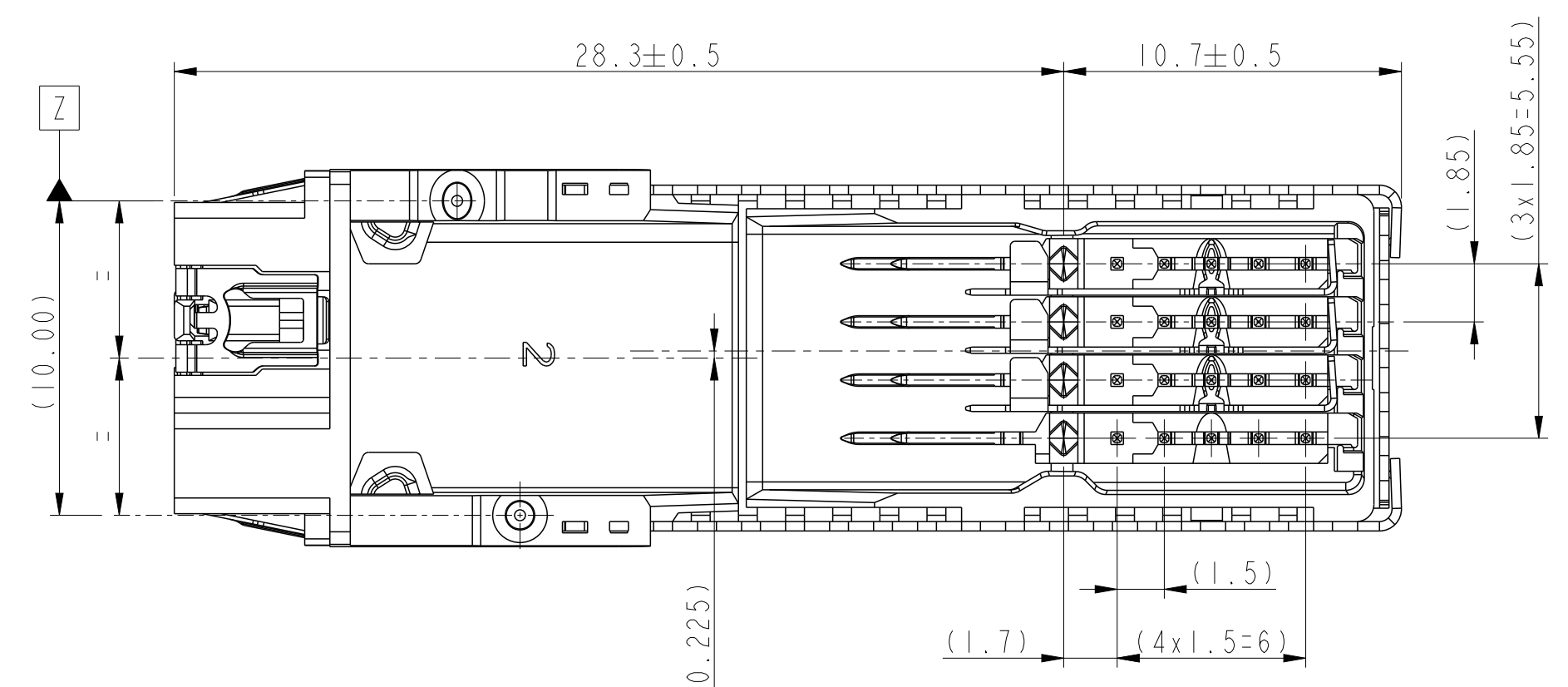
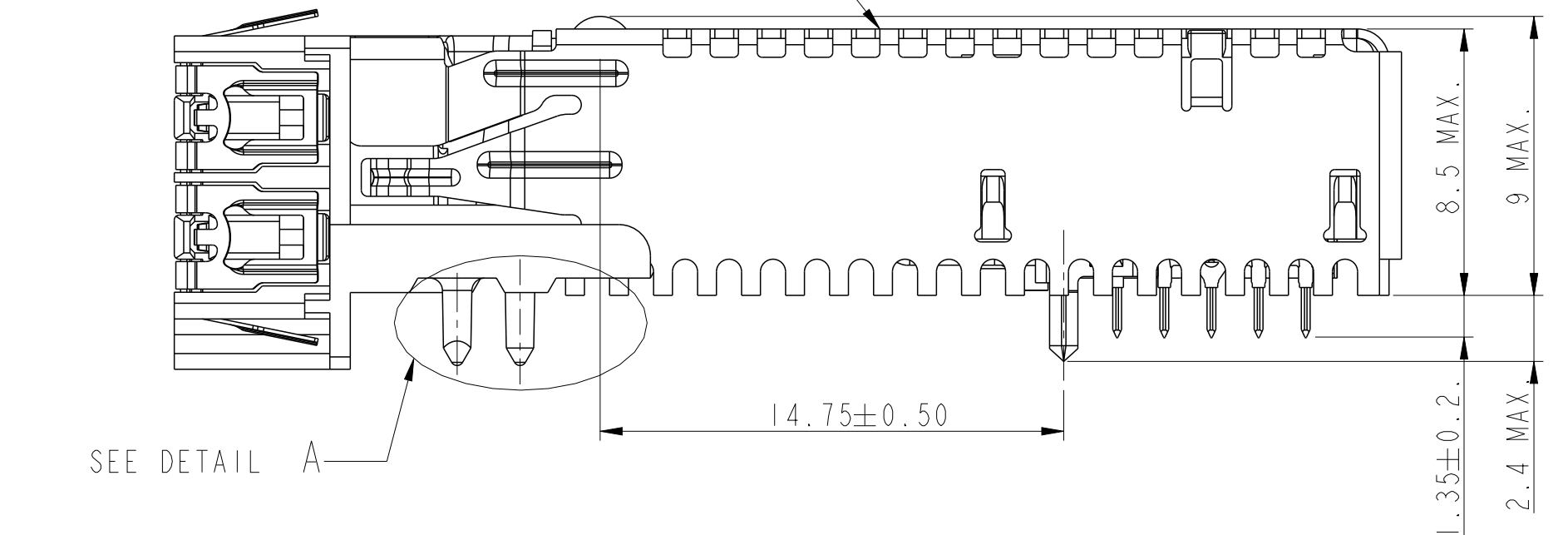
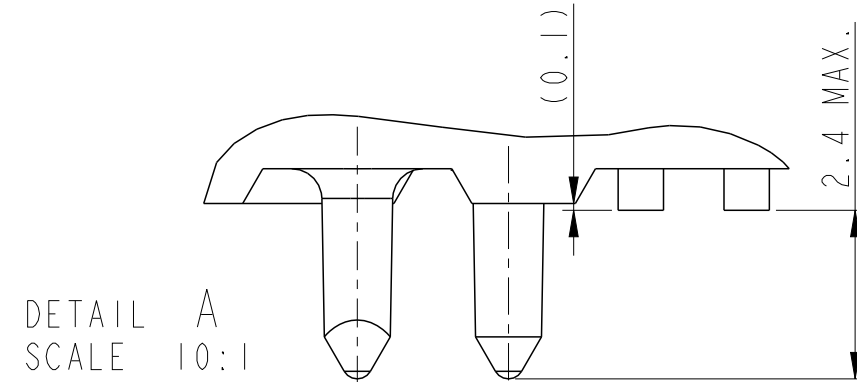
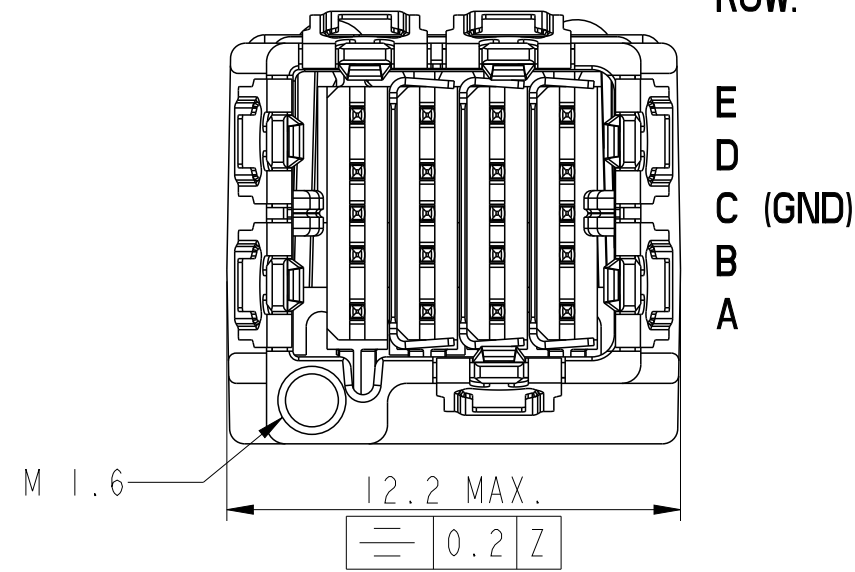

- NOTES:
- MATES WITH CABLE CONNECTOR 10044473-SERIES
 - MATERIALS:
DIECAST-ENTRY: ZINC ALLOY, PLATING/FINISH: Sn PLATED WITH Ni OVER Cu UNDERLAYER, TOPCOVER - COPPER ALLOY, PLATING/FINISH: Sn PLATED WITH Ni UNDERLAYER, SPRINGS - STAINLESS STEEL, RETAINER - HIGH TEMPERATURE FLAME RETARDANT THERMOPLAST, COLOUR NATURAL, VERTICAL SHIELDS - COPPER ALLOY, PLATING/FINISH: Sn WITH Ni UNDERLAYER, HEADER IMLA'S - COPPER ALLOY OVERMOLDED WITH HIGH TEMPERATURE FLAME RETARDANT THERMOPLAST, COLOUR BLACK, LEADFRAME PLATING/FINISH: NICKEL UNDERPLATING, PALLADIUM-NICKEL ALLOY WITH GOLD OVERPLATING IN CONTACT ZONE, Sn IN SOLDER TAIL AREA.
 - CONNECTOR CAN BE PICKED UP WITH A MECHANICAL GRIPPER OR A VACUUM NOZZLE, NOZZLE DIAMETER UP TO 9 MM. ESTIMATED MAXIMUM MASS OF THE PRODUCT 6.00 G.
 - COLUMN 1 IS ALWAYS FILLED WITH AN UNSHIELDED IMLA.
 - FCI PRODUCT SPECIFICATION GS-12-314.
 - PACKAGING: TAPE AND REEL ACCORDING TO EIA-481-B, SEE LAST SHEET.
 - THIS PRODUCT MEETS EUROPEAN UNION DIRECTIVES AND OTHER COUNTRY REGULATIONS AS DESCRIBED IN GS-22-008.
 - THE CONNECTOR WILL WITHSTAND EXPOSURE TO 260°C PEAK TEMPERATURE IN A CONVECTION, INFRA-RED OR VAPOR PHASE REFLOW OVEN. FOR MORE DETAILS AND MOUNTING RECOMMENDATIONS, SEE FCI APPLICATION GUIDE GS-20-048.

spec ref *	dr Terran Huang	2009/01/22	projection	mm	size A2	scale 1:1
tolerance std	eng Norman Luo	2017/05/25			ecn no ELX-DG-27032-1	rel level Released
ISO 406 ISO 1101	chr -	2017/05/31				
surface	ISO 1302	appr Heaven Cen	Amphenol FCI TITLE HEADER 8 PAIR DENS1-SHIELD I/O www.fci.com cat. no.		dwg no 10044471 rev K	Product - Customer Drw sheet 1 of 4

Amphenol FCI

© 2016 AFCI

RECOMMENDED HOLE PATTERN AND TRACE DIMENSIONS FOR FULLY EQUIPPED BOARD CONNECTORS. (SEE SHEET 1)

RECOMMENDED ISLAND PATTERN

RECOMMENDED STENCIL LAYOUT MIN. REQUIRED APERTURES FOR STENCIL THICKNESS 0.125 MM

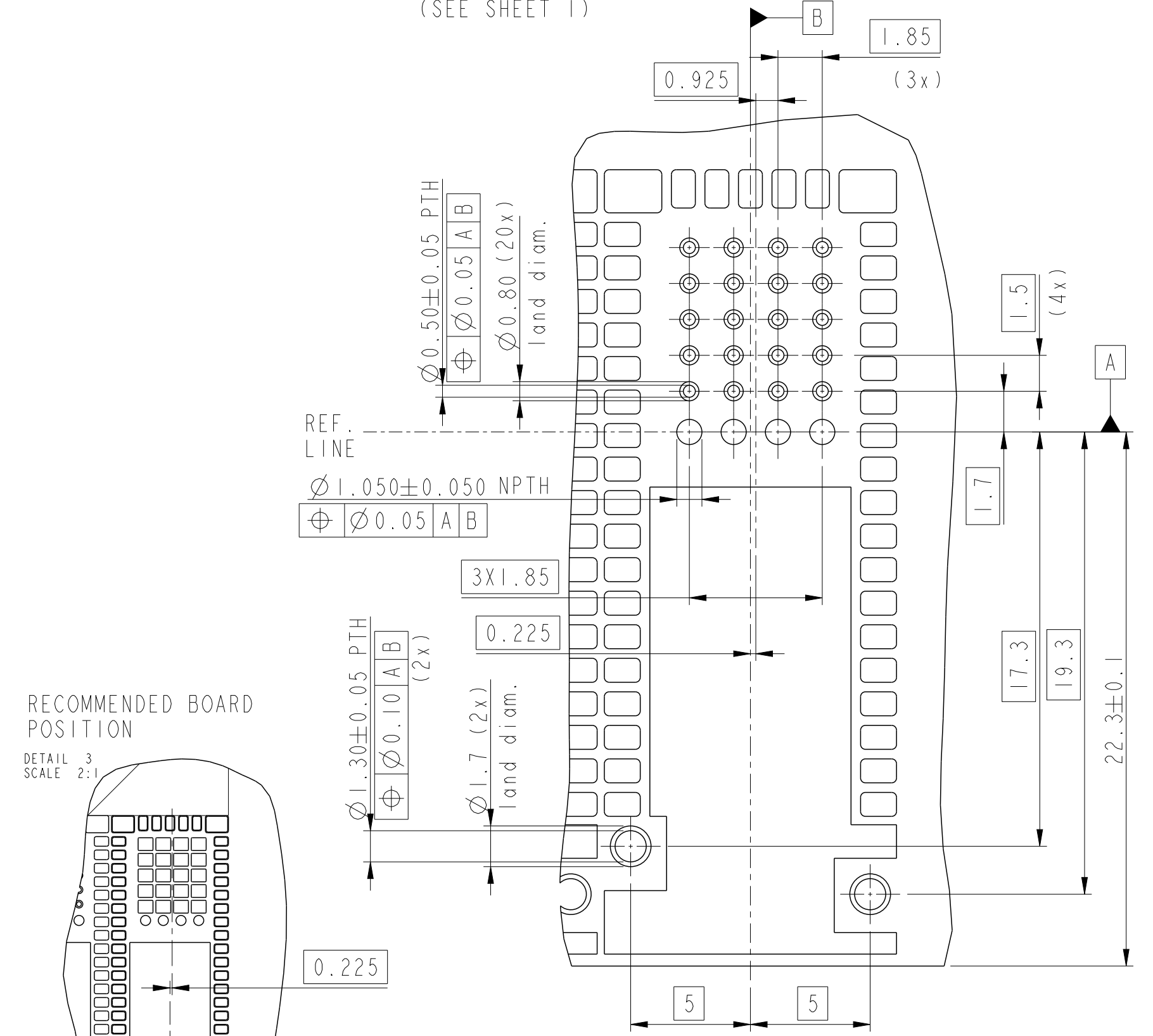

RECOMMENDED BOARD POSITION
DETAIL 3
SCALE 2:1

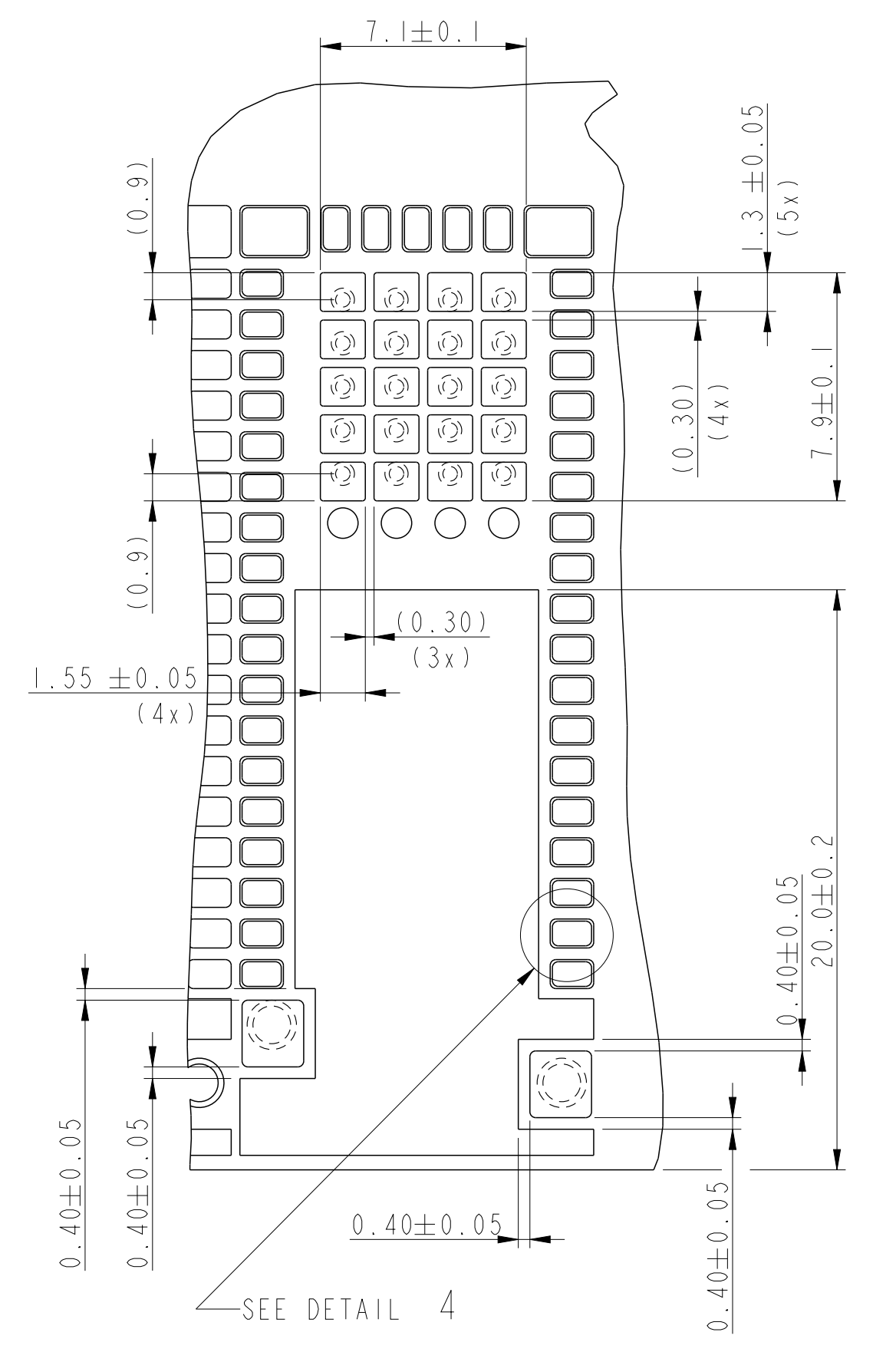
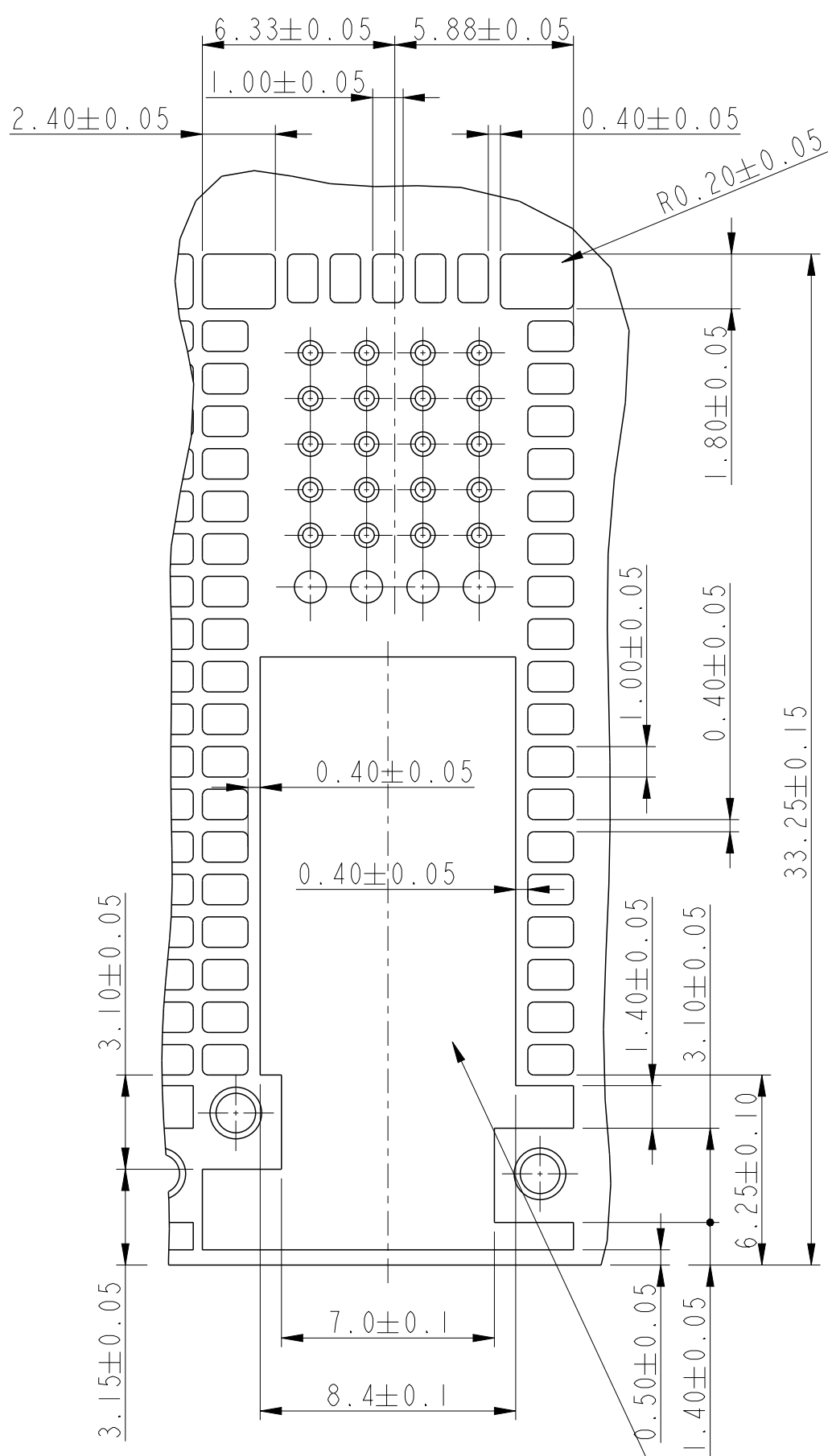
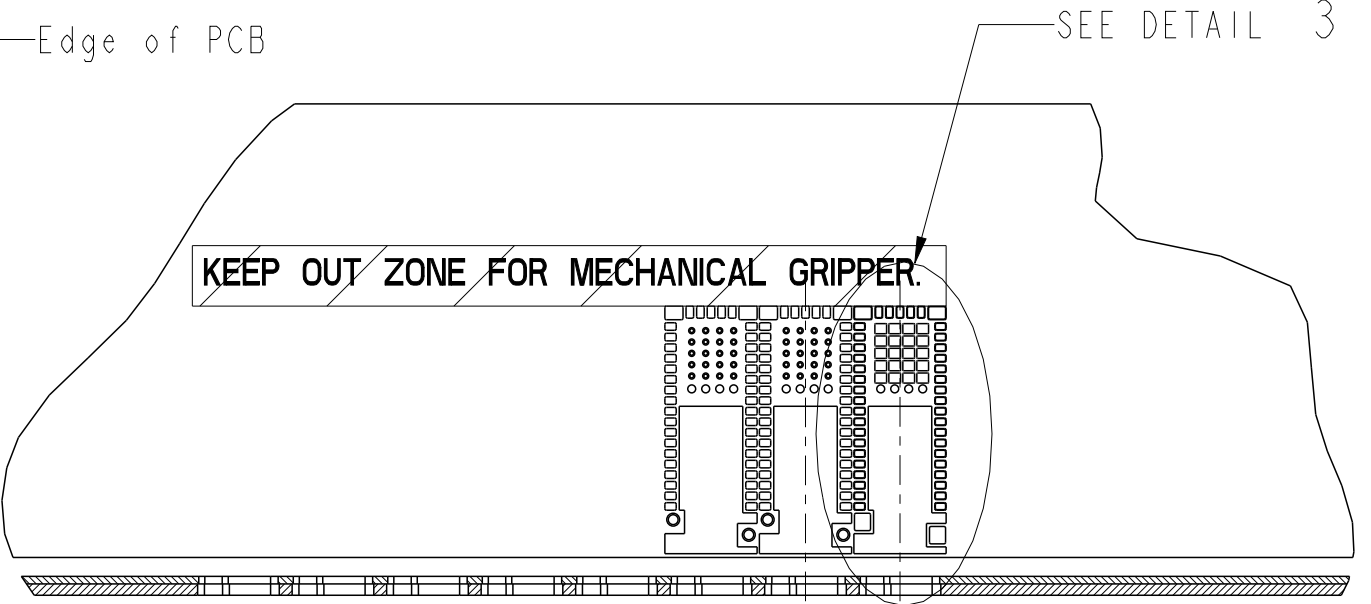
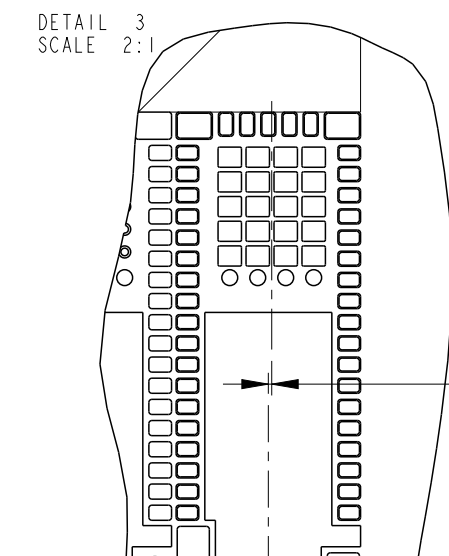

SOLDER MASK NOT ALLOWED ON THIS REFERENCE PLANE AND LANDS. PLATING THICKNESS MUST BE CONSTANT OVER CONTACT AREA.

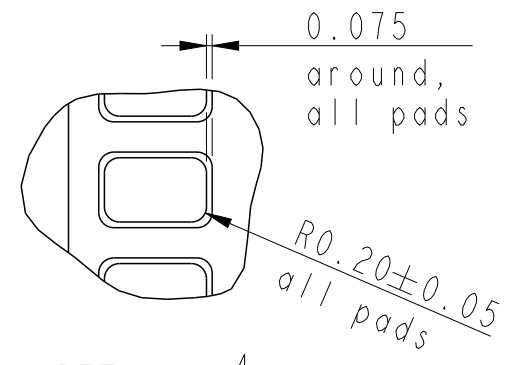

DETAIL 4
SCALE 10:1

THE SOLDER CONTENT IN THE PASTE SHOULD BE SUFFICIENT, TYPICALLY 50% VOLUME PERCENTAGE. THE SCREEN PRINTING PROCESS (ANGLE, SPEED, PRESSURE ETC.) MUST BE OPTIMISED SO THAT ENOUGH SOLDER IS AVAILABLE.

spec ref	*	dr	Terran Huang	2009/01/22	projection	mm	size	A2	scale	1:1
tolerance std	ISO 406 ISO 1101	eng	Norman Luo	2017/05/25		mm	ecn no	ELX-DG-27032-1		
	TOLERANCES UNLESS OTHERWISE SPECIFIED	chr		rel level				Released		
surface	-	appr	Heaven Cen	2017/05/31	product family	-	rel level	Released		
ISO 1302	linear	0.X	±0.3	Amphenol FCI www.fci.com	TITLE		HEADER 8 PAIR		cat. no. -	Product - Customer Drw
		0.XX	±0.2		DENSE-SHIELD I/O		dwg no 10044471	rev K		
	angular	0°	±2°		sheet 2 of 4					

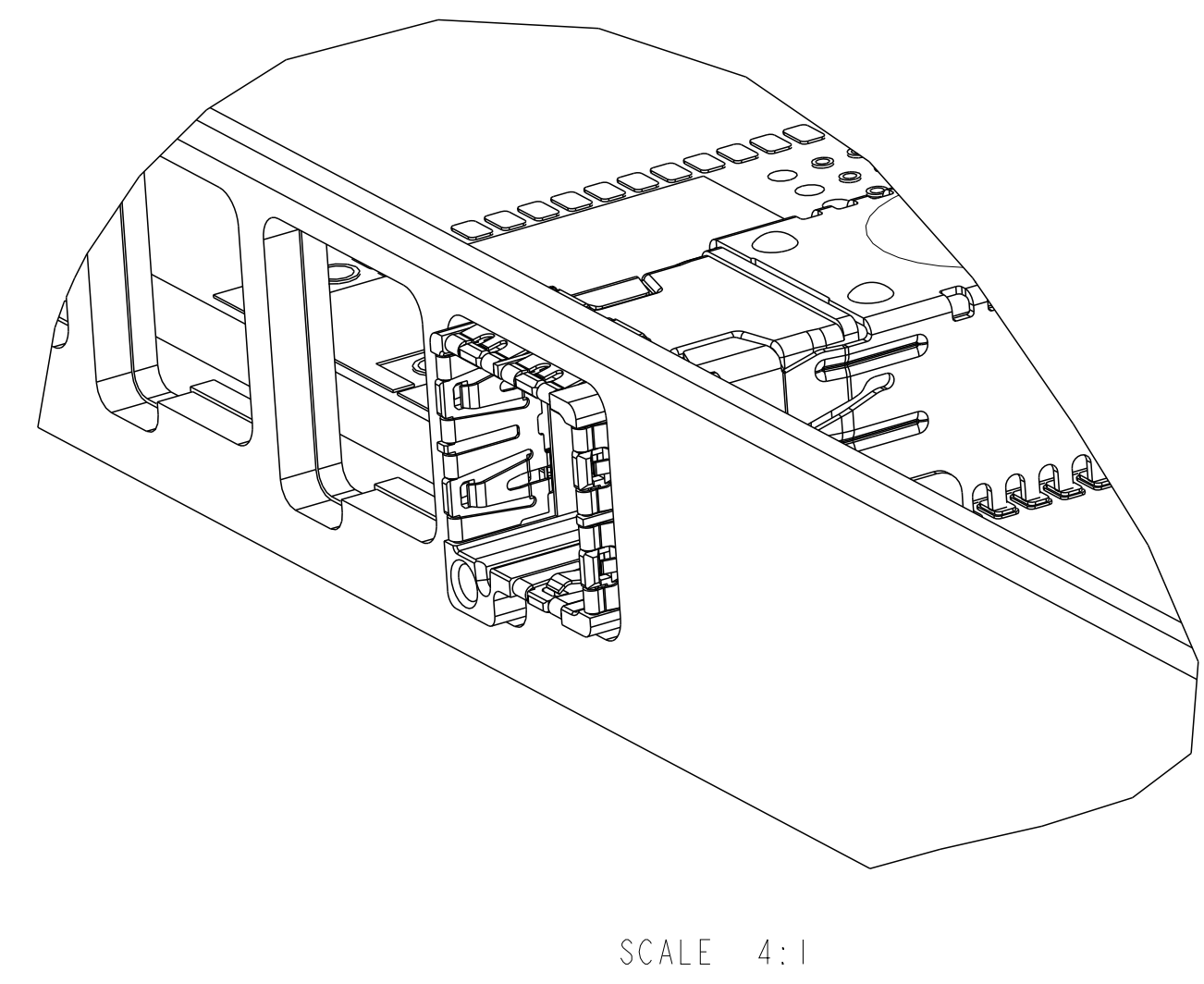
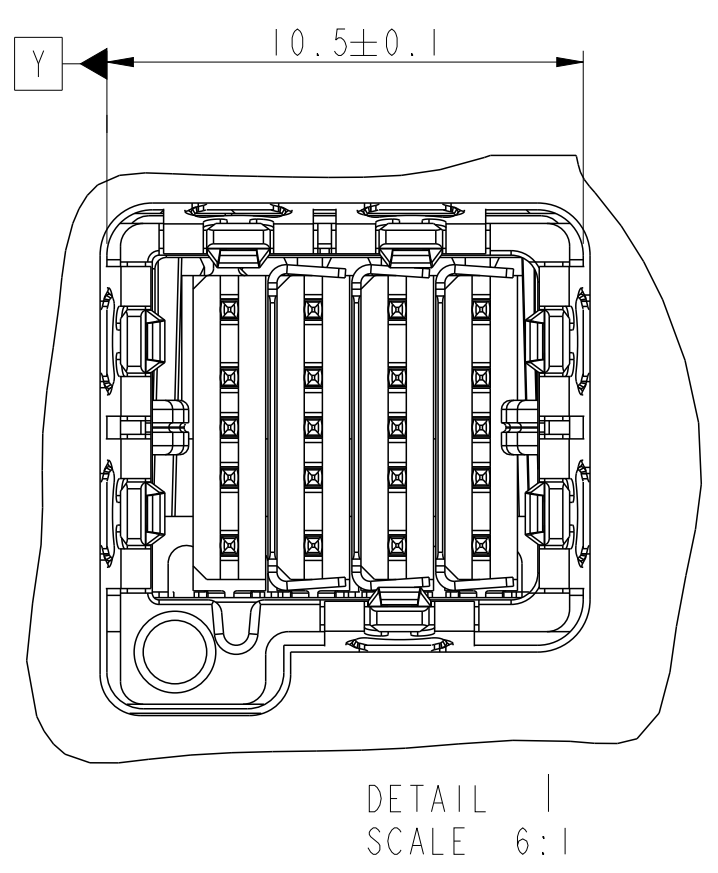
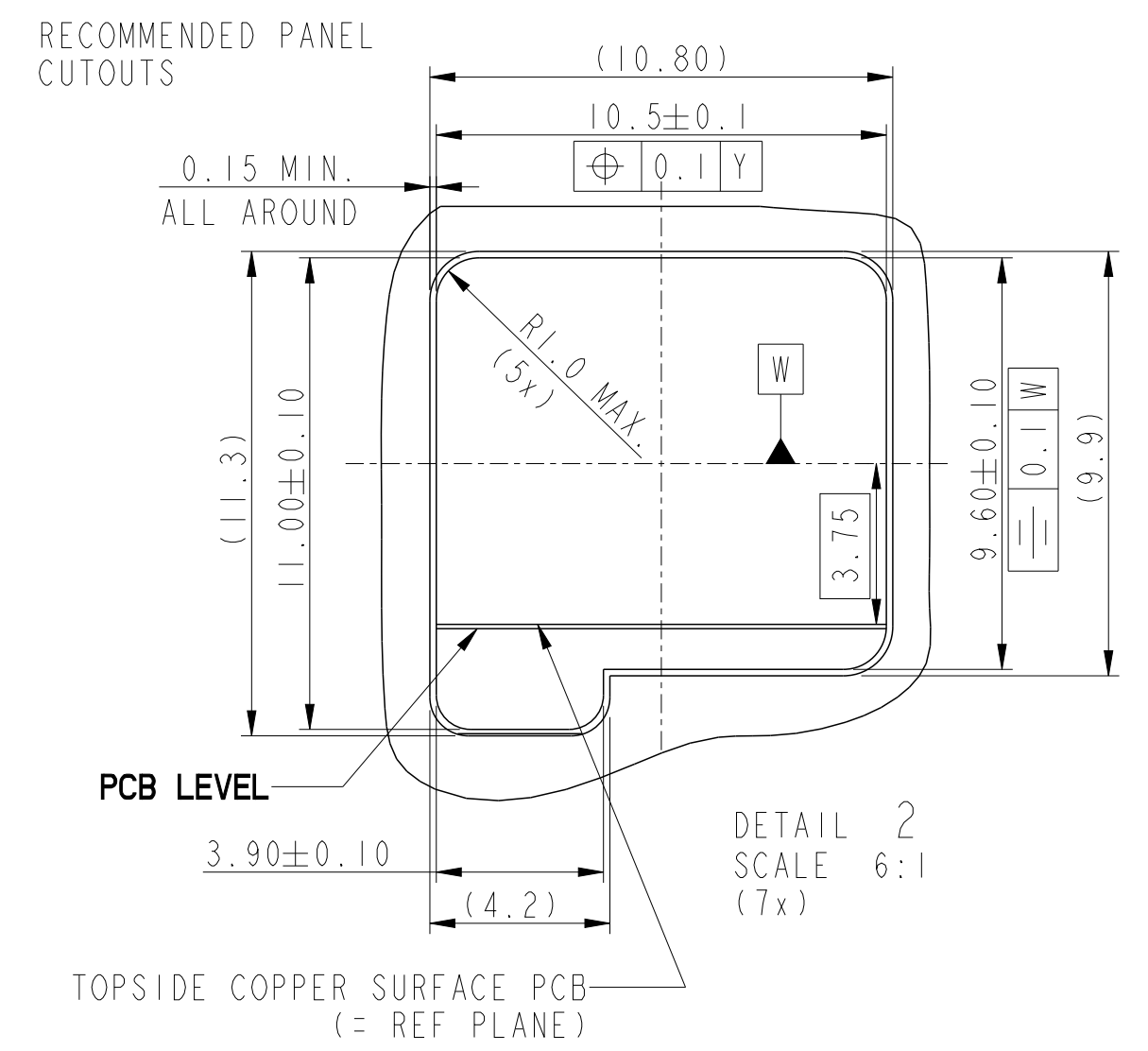
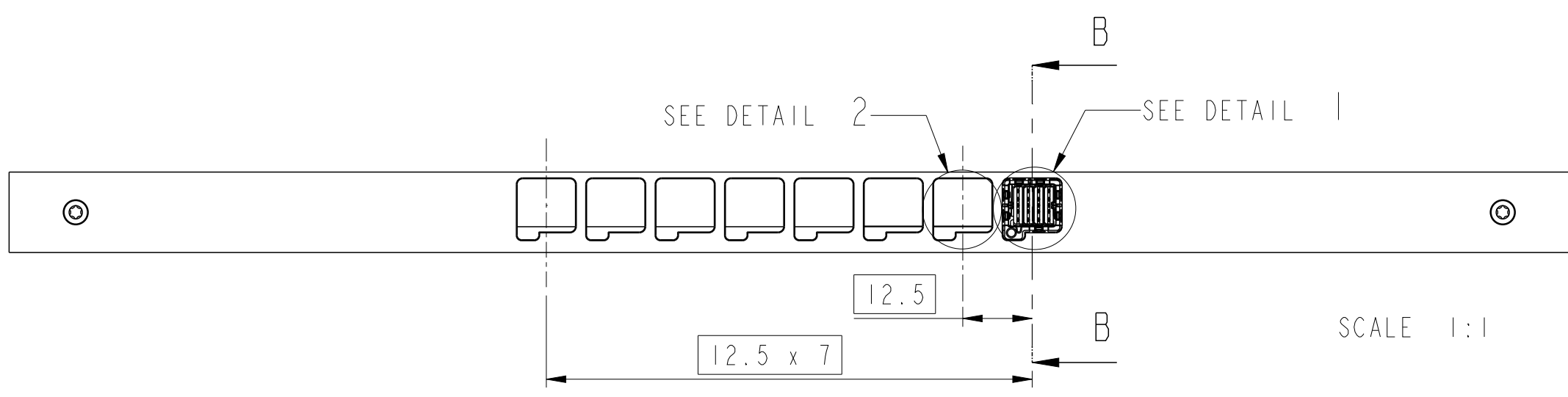
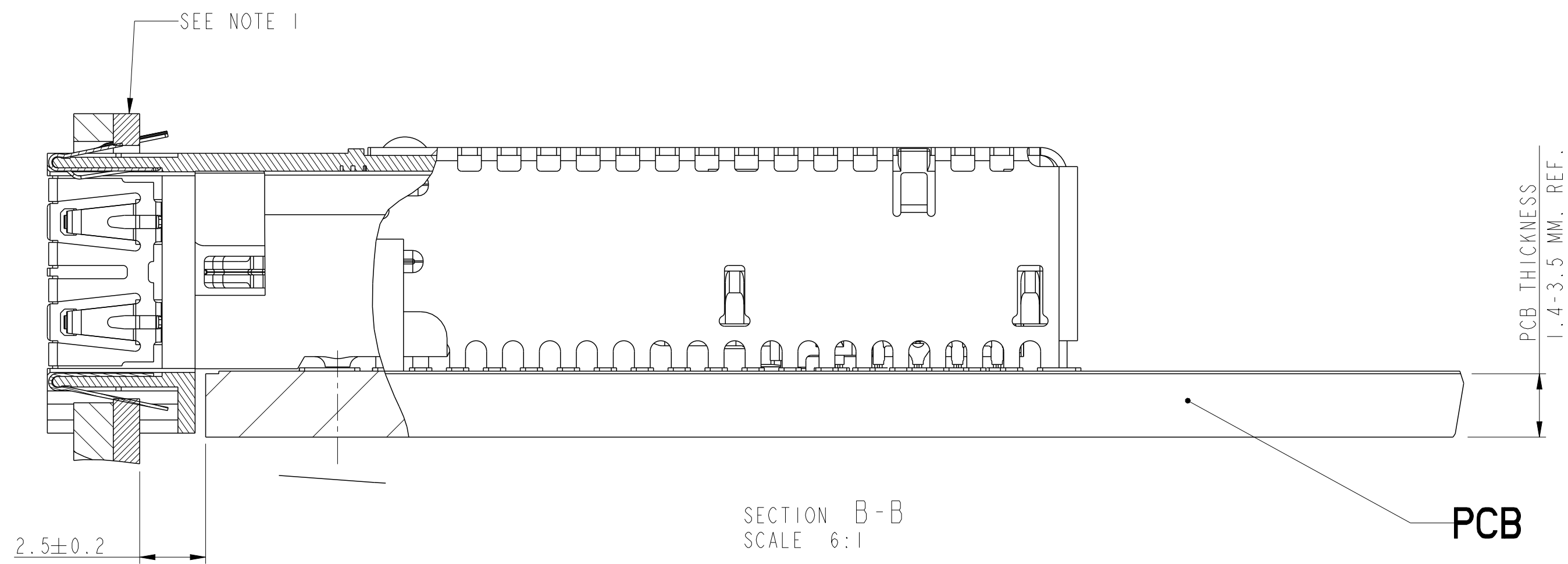

NOTE 1:
A DESIGN IS SHOWN WITH AN INNER CONDUCTIVE FRONTPANEL (FOR GROUNDING), AND A COSMETIC OUTER PANEL. THE INNER PANEL IS RECOMMENDED TO BE Sn PLATED ON THE CUTOUT EDGES.

spec ref	*	dr	Terran Huang	2009/01/22	projection	mm	size	A2	scale	6:1
tolerance std	ISO 406 ISO 1101	eng	Norman Luo	2017/05/25		mm	ecn no	ELX-DG-27032-1		
TOLERANCES UNLESS OTHERWISE SPECIFIED		chr	-	rel level				Released		
surface	linear	appr	Heaven Cen	2017/05/31	product family	-	rel level	Released	cat. no.	-
ISO 1302	angular			TITLE HEADER 8 PAIR DENSII-SHIELD I/O		dwg no 10044471	rev K	Product - Customer Drw sheet 3 of 4		

1 2 3 4 5 6 7 8

A

B

C

D

E

F

A

B

C

D

E

F

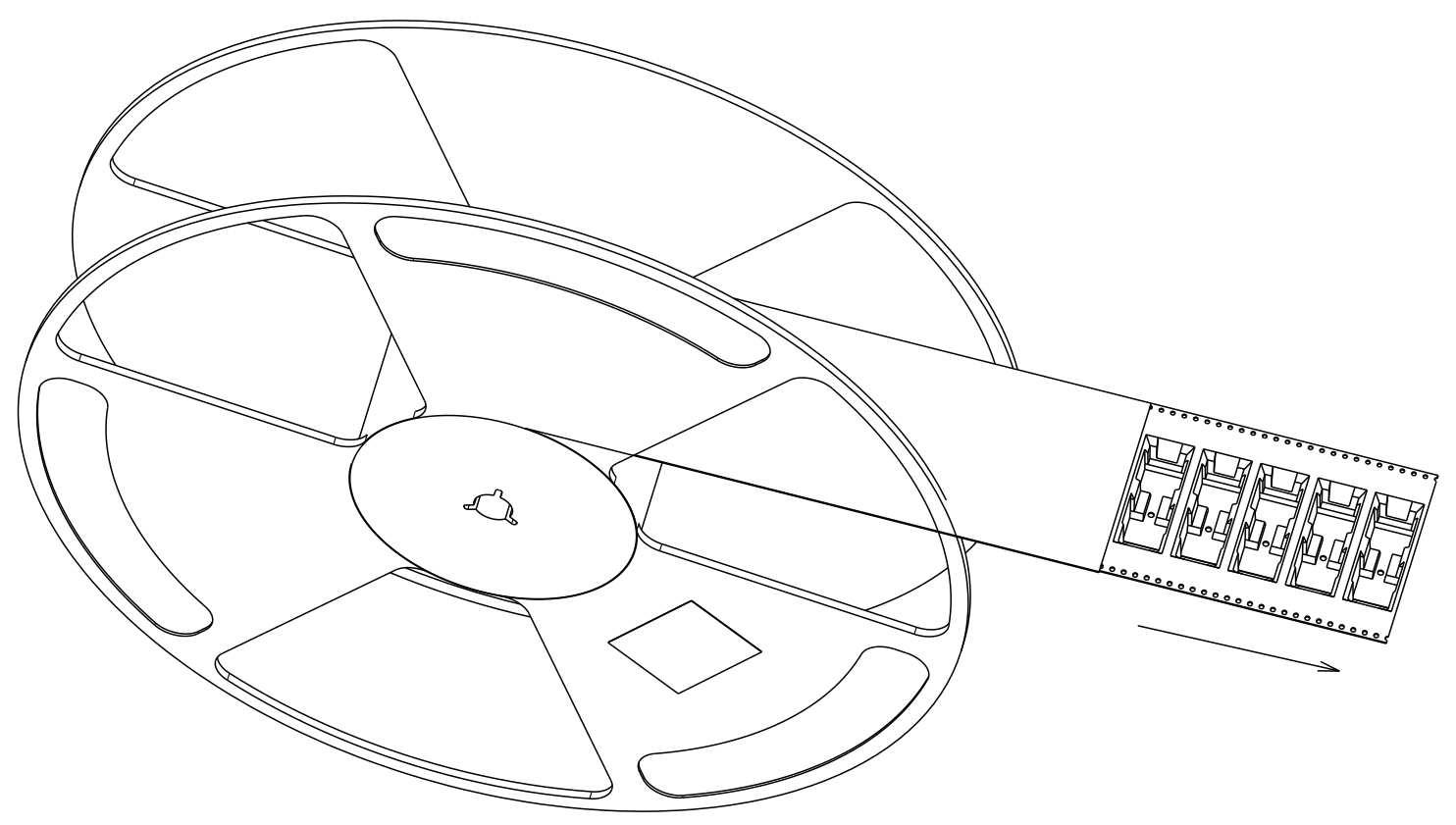

SCALE 2:5

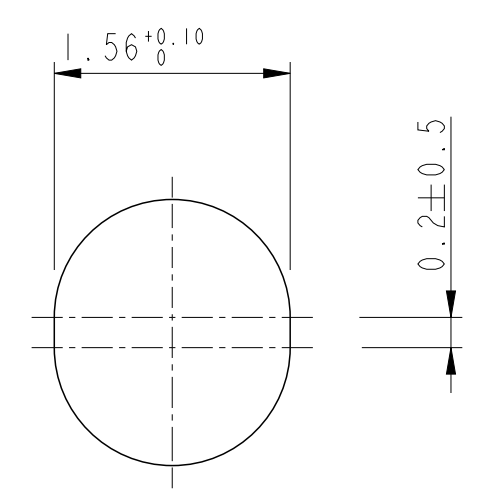

DETAIL B
SCALE 20:1

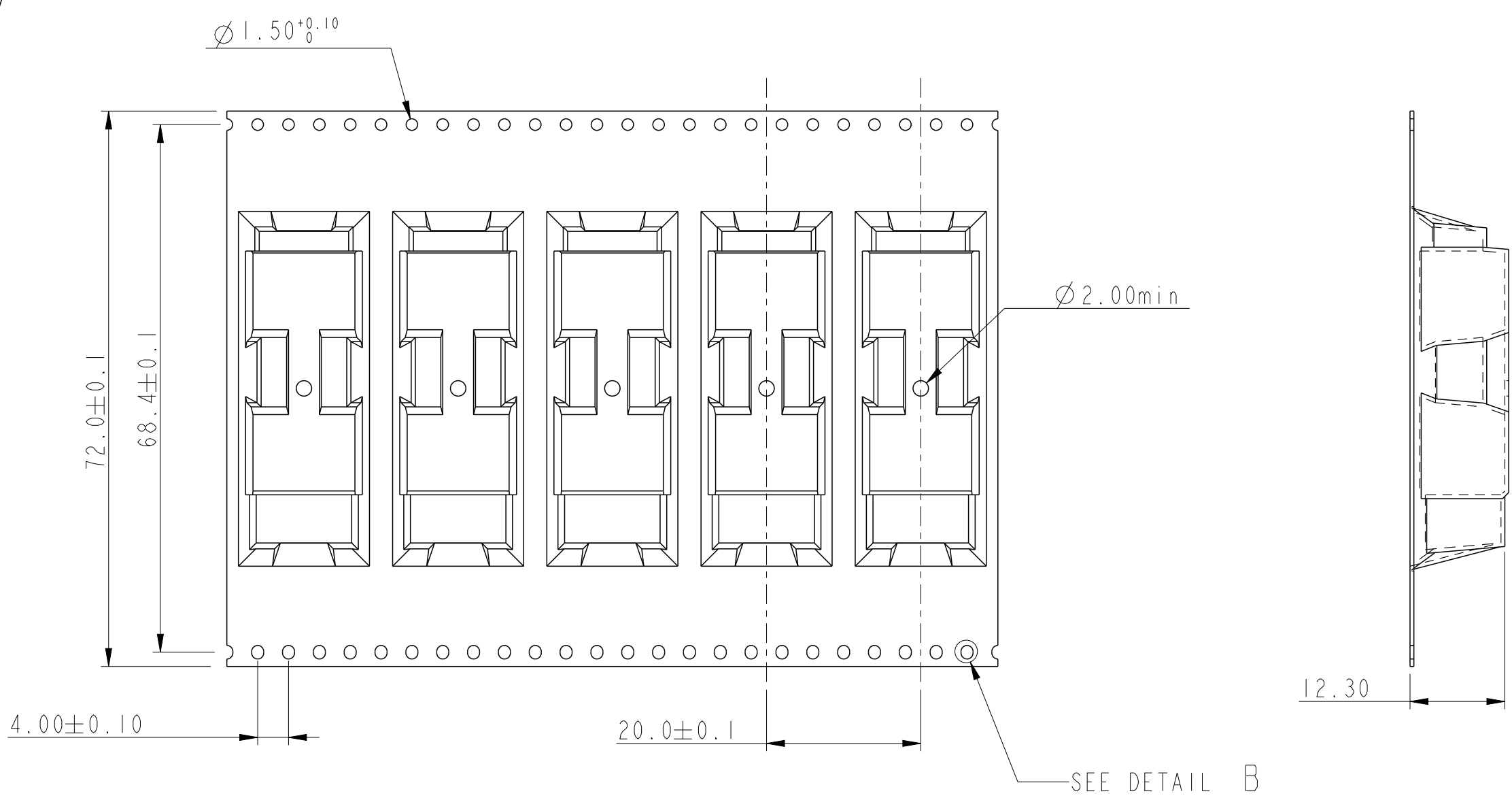

NOTE:
1: MATERIAL CARRIER TAPE: Polystyrene;
2: MATERIAL COVER TAPE : Polyester;
3: THE PACKAGING IS ANTISTATIC TREATED.

Amphenol
FCi

© 2016 AFci

spec ref	*	dr	Terran Huang	2009/01/22	projection	mm	size	A2	scale	1:6	
tolerance std	ISO 406 ISO 1101	eng	Norman Luo	2017/05/25			ecn no	ELX-DG-27032-1			
TOLERANCES UNLESS OTHERWISE SPECIFIED		chr	-	appr			Heaven Cen	2017/05/31	rel level	Released	
surface	ISO 1302	linear	0.X	±0.3	product family		-	cat. no.	-		
			0.XX	±0.2	Amphenol FCi		title	HEADER 8 PAIR			
			0.XXX	±0.1	Densi-Shield I/O		dwg no	10044471			
		angular	0°	±2°	Product - Customer Drw		rev	K			

PDS: Rev :K

STATUS:Released

Printed: May 31, 2017