

THIS DRAWING IS UNPUBLISHED. RELEASED FOR PUBLICATION
 © COPYRIGHT - By - ALL RIGHTS RESERVED.

LOC	DIST	REVISIONS			
P	LTR	DESCRIPTION	DATE	DWN	APVD
H	-				
	P	REVISED PER ECO-17-007566	13DEC2017	AP	DG

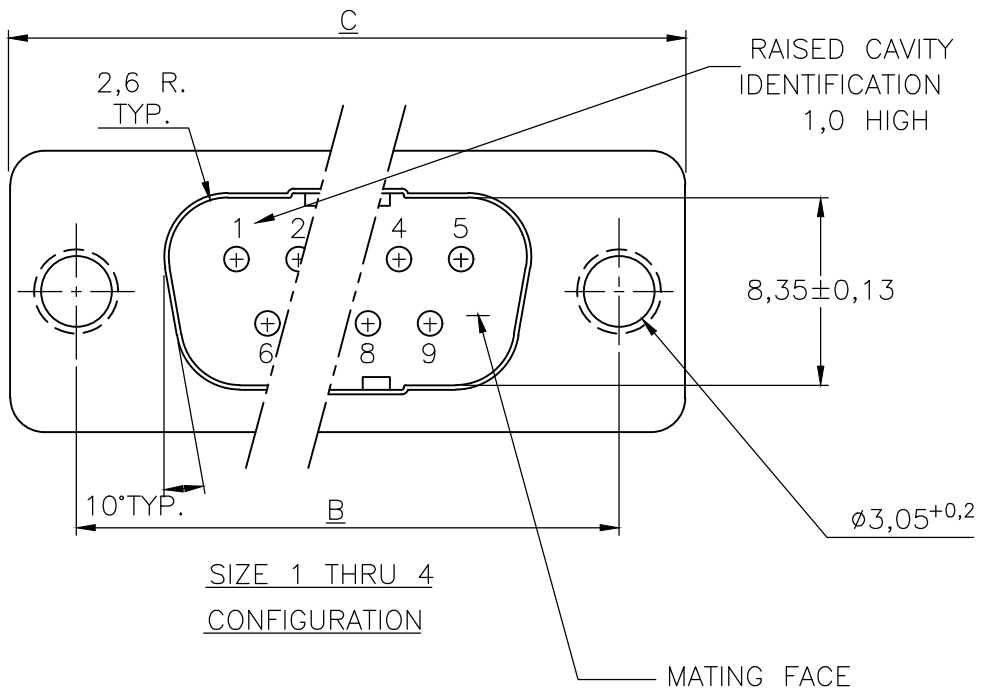

NOTES:

- THIS PLUG ACCEPTS SIZE 20 PIN CONTACTS.
 - MAXIMUM WIRE INSULATION RECOMMENDED FOR USE WITH THIS PLUG IS 1,73 DIA. MAX..
 - RETENTION TINES ARE AN INTEGRAL PART OF INSERT.
 - FOLLOWING INSERTION/REMOVAL TOOLS ARE RECOMMENDED FOR USE WITH THESE CONNECTORS:

32-28AWG/28-24AWG CONT's	24-20AWG CONTACTS
91067-3 INSERTION/REMOVAL	91067-2 INSERTION/REMOVAL
726363-1 INSERTION ONLY	726363-1 INSERTION ONLY
	726364-1 REMOVAL ONLY
- △5 CONTACTS SHOWN FOR ILLUSTRATION ONLY, NO PART OF CONNECTOR PACKAGE ;MUST BE ORDERED SEPARATELY.
- △6 RAISED CAVITY IDENTIFICATION NUMBERS ON WIRE SIDE ARE WHITENED FOR -9 P/N'S.

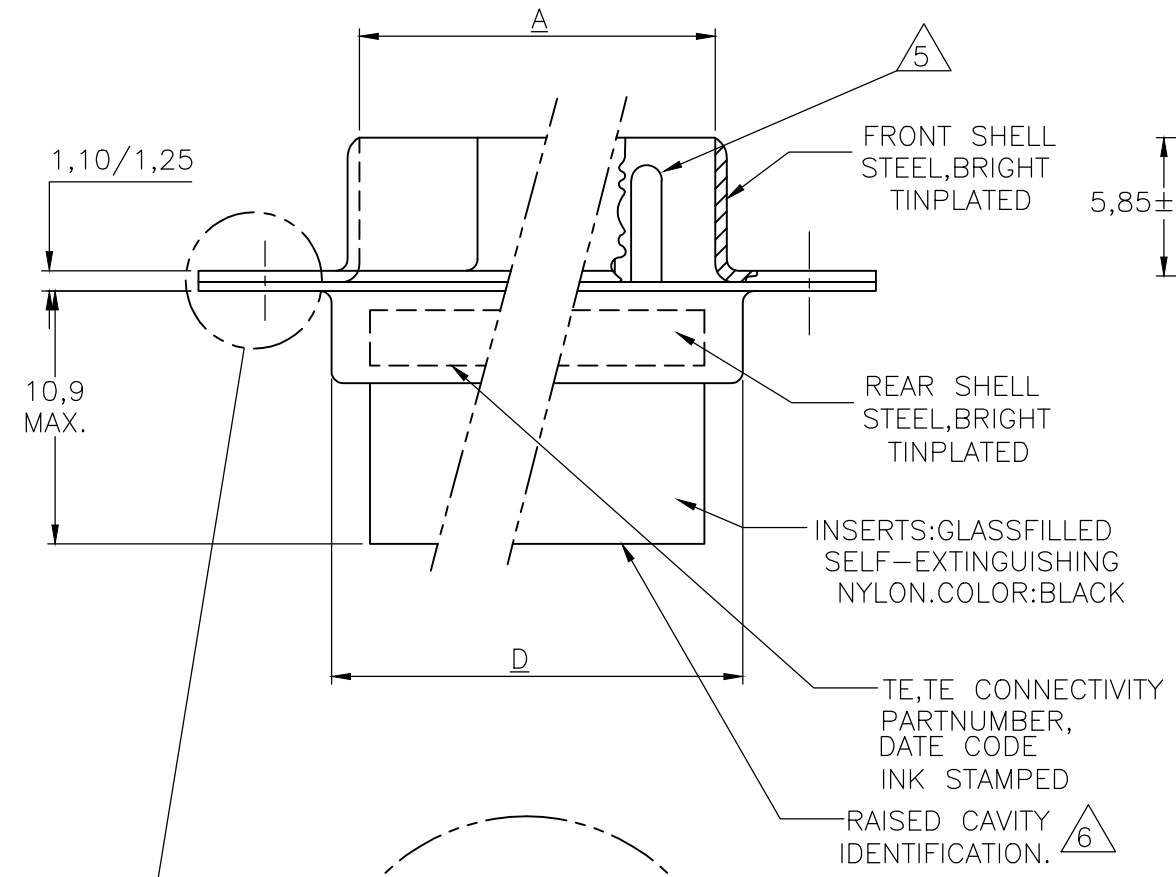

D	C	B	A	NR.OF POS	SIZE	ORDER NUMBER
55,3	66,9	61,1	52,9	50	5	167296-9 167296-1
57,7	69,3	63,5	55,4	37	4	167295-9 167295-1 OBSOLETE
41,3	53,0	47,0	39,0	25	3	167294-9 167294-1
27,5	39,1	33,3	25,3	15	2	167293-9 167293-1
19,3	30,8	25,0	16,9	9	1	167292-9 167292-1

FOR DETAILS SIZE 5, SEE SHEET 2.

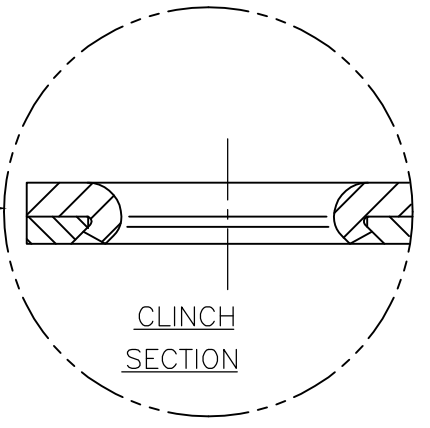

THIS DRAWING IS A CONTROLLED DOCUMENT.		DWN B.MOOIJ 20NOV87	TE Connectivity		
DIMENSIONS: mm		CHK -			
TOLERANCES UNLESS OTHERWISE SPECIFIED:		APVD -	HDP-20 PLUG CONNECTOR, SIZE 1-4		
0 PLC ± -		PRODUCT SPEC -	SIZE CAGE CODE DRAWING NO RESTRICTED TO		
1 PLC ± 0,2		APPLICATION SPEC -	A3 00779 C-167292		
2 PLC ± -		WEIGHT -	CUSTOMER DRAWING SCALE NTS SHEET 1 OF 2 REV P		
3 PLC ± -					
4 PLC ± -					
ANGLES ± 2°					
MATERIAL -	FINISH -				

THIS DRAWING IS UNPUBLISHED. RELEASED FOR PUBLICATION
 © COPYRIGHT - By - ALL RIGHTS RESERVED.

LOC	DIST	REVISIONS					
H	-	P	LTR	DESCRIPTION	DATE	DWN	APVD
		-	-	SEE SHEET 1	-	-	-

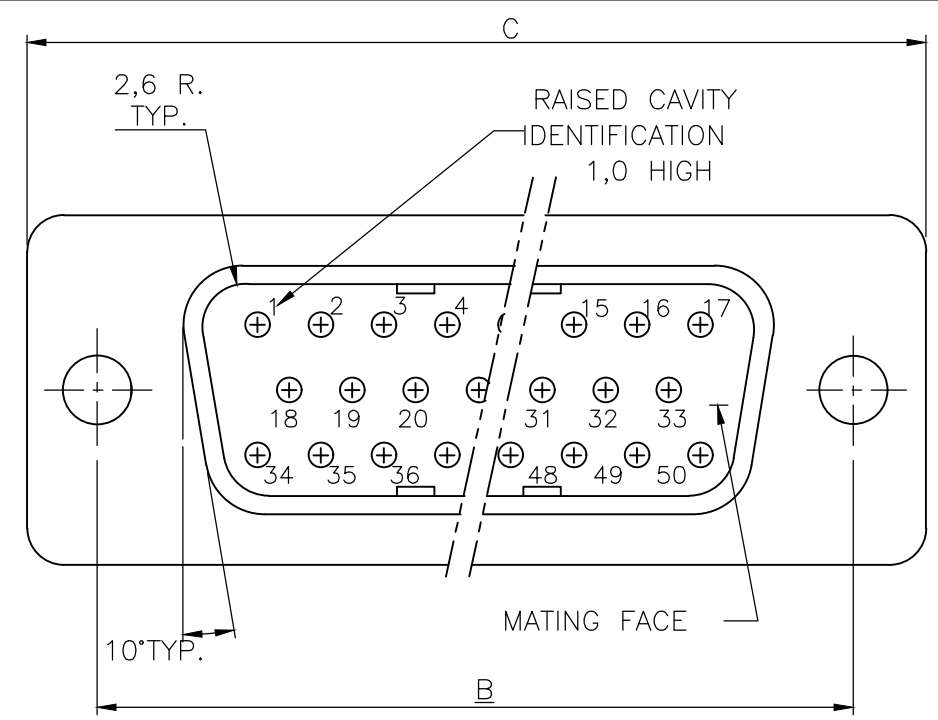

SIZE 5
CONFIGURATION

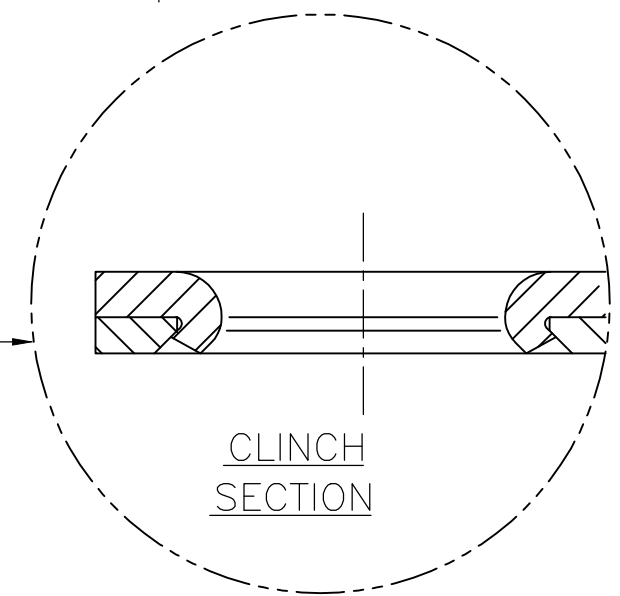
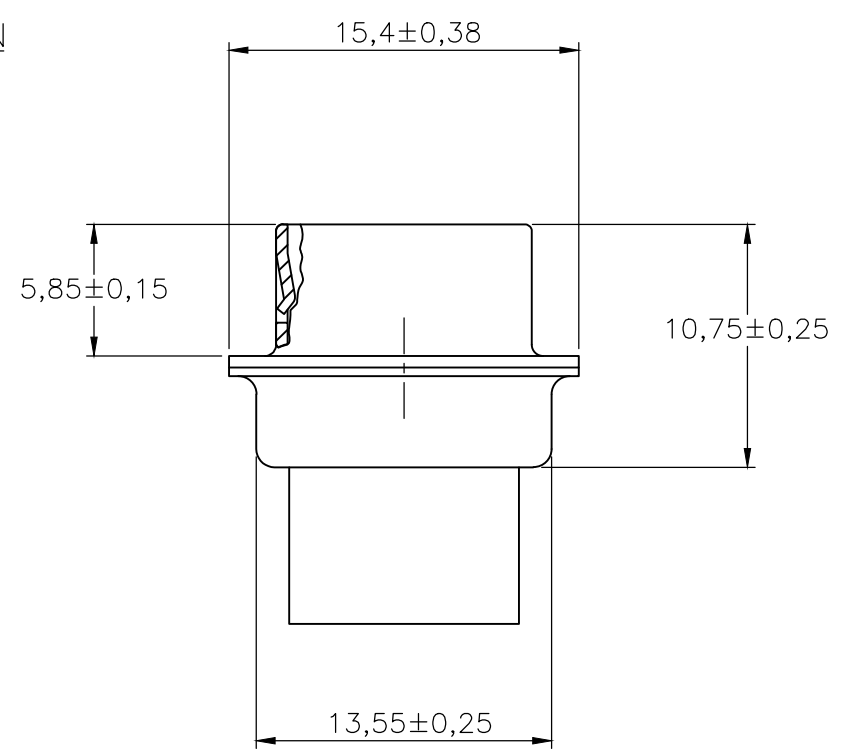
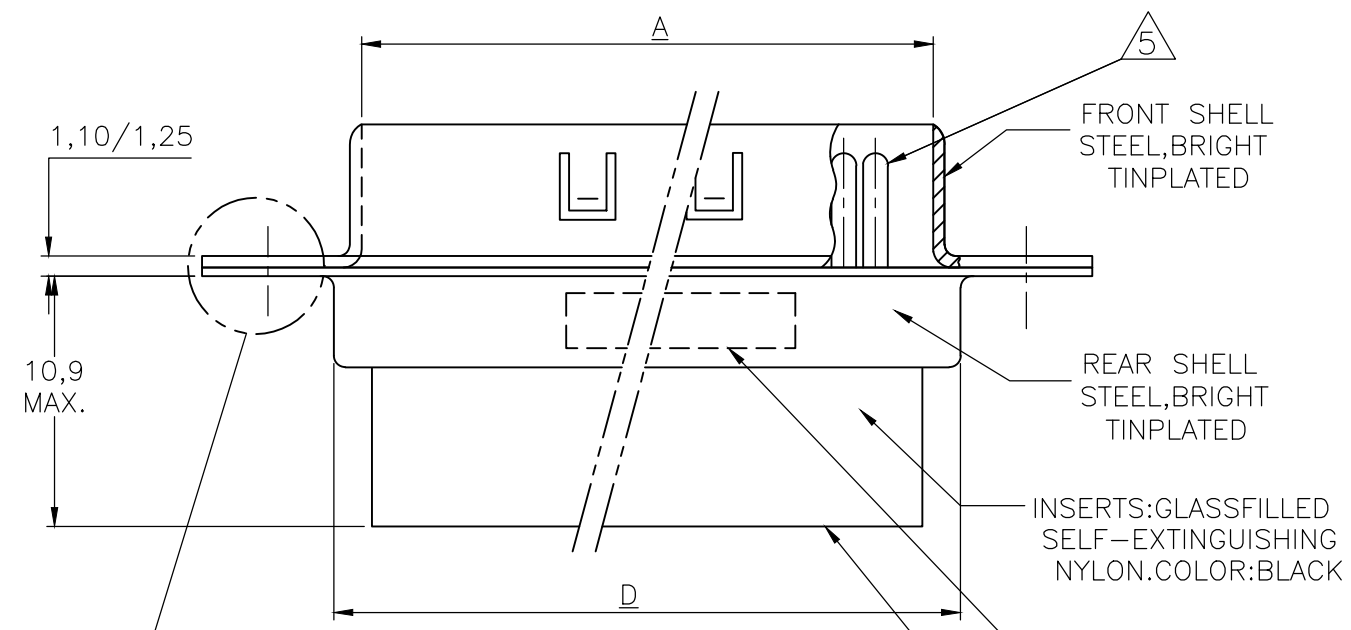

THIS DRAWING IS A CONTROLLED DOCUMENT.		DWN B.MOOIJ 20NOV87	TE Connectivity	
DIMENSIONS: mm		CHK -		
TOLERANCES UNLESS OTHERWISE SPECIFIED:		APVD -	NAME	
0 PLC ± -		PRODUCT SPEC -	HDP-20 PLUG CONNECTOR, SIZE 5	
1 PLC ± 0,2		APPLICATION SPEC -	SIZE	CAGE CODE
2 PLC ± -		WEIGHT -	A3	00779
3 PLC ± -		CUSTOMER DRAWING	DRAWING NO	RESTRICTED TO
4 PLC ± -			C-167292-C	-
ANGLES ± 2°			SCALE	SHEET
FINISH -			NTS	2 OF 2
			REV	P