

ISS.	AMEND	DATE
1	ISSUED	16/02/18

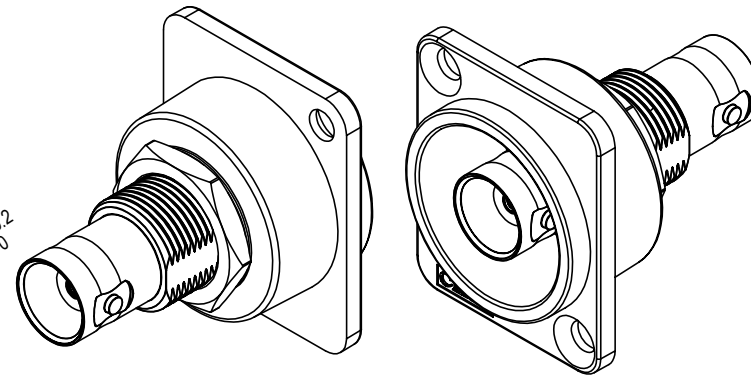

ITEM	DESCRIPTION	MATERIAL	FINISH
1	FRAME	POLYAMIDE UL94 V2	BLACK
2	NUT	BRASS	NICKEL
3	WASHER	BRASS	NICKEL
4	BNC	ALLOY	NICKEL
5	BNC INSULATION	POM	BLACK

CP303090 - CSK HOLES

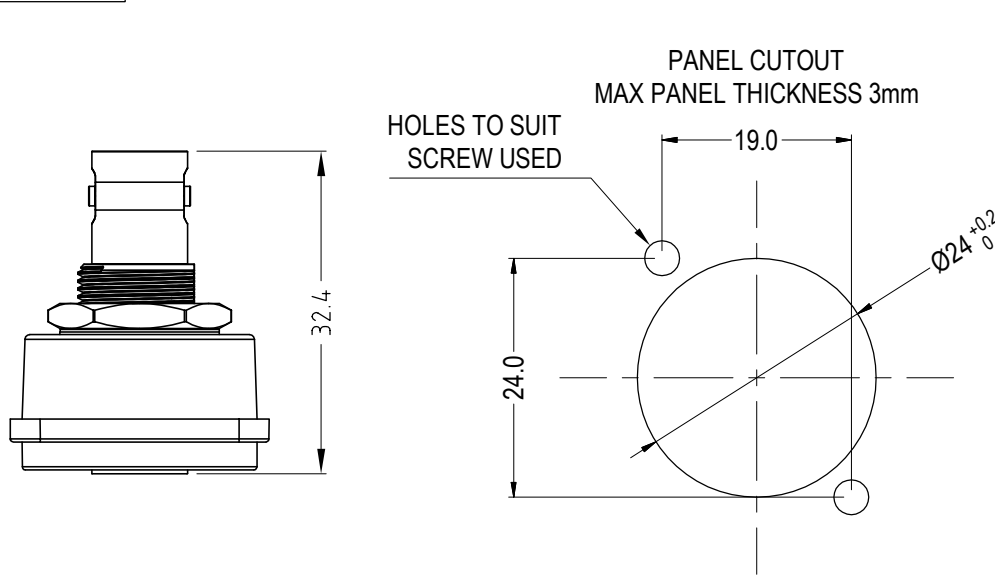
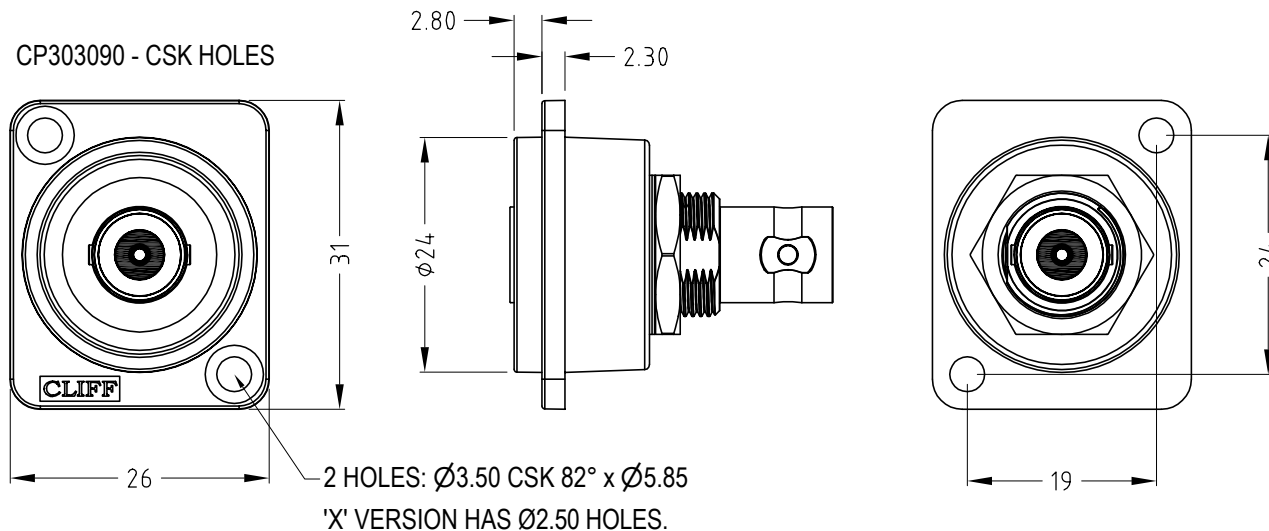

VARIANTS	
PART NO.	HOLE DETAILS
CP303090	HOLE Ø3.50xCSK 82°x Ø5.85
CP303090X	PLAIN HOLE Ø2.50

CP303090X - Ø2.50 PLAIN HOLES

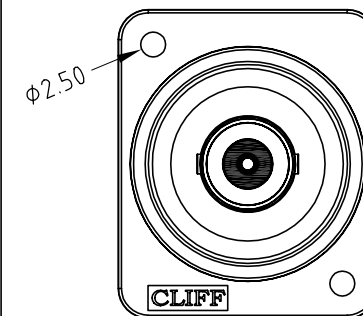

RoHS
COMPLIANT

TOLERANCE
 NO DEC. PLACE ±
 1 DEC. PLACE ±
 2 DEC. PLACE ±
 HOLE Ø ±
 ANGLES ±
 UNLESS OTHERWISE STATED

Cliff Electronic Components Ltd.

76 Holmehorpe Avenue, Holmehorpe Industrial Estate,
 Redhill, Surrey, RH1 2PF, England, UK
 Tel: 01737-771375 Fax: 01737-766012 Website: www.cliffuk.co.uk

DIMENSIONS IN MILLIMETERS UNLESS OTHERWISE STATED. WORK TO DIMENSIONS. REMOVE ALL BURRS. IF IN DOUBT ASK.

3rd ANGLE PROJECTION:

DO NOT SCALE

MATERIAL: SEE TABLE

TITLE: XRP12 BNC 50 OHM

FINISH: SEE TABLE

DRAWN: T.J.O.

APPROVED: D.P.J.

DRWG. No. **CP303090**

FORM: A4DRWGH